



THS SERIES[®]

HIGH RATE SAND FILTER



INSTALLATION AND USER'S GUIDE

IMPORTANT SAFETY INSTRUCTIONS
READ AND FOLLOW ALL INSTRUCTIONS
SAVE THESE INSTRUCTIONS

CUSTOMER SERVICE / TECHNICAL SUPPORT

If you have questions about ordering Pentair replacement parts, and pool products, please contact:

Customer Service and Technical Support, USA

(8 A.M. to 5 P.M. — Eastern/Pacific Times)

Phone: (800) 831-7133

Fax: (800) 284-4151

Website

Visit www.pentair.com to find more information about Pentair products.

Sanford, North Carolina (8 A.M. to 5 P.M. ET)

Phone: (919) 566-8000

Fax: (919) 566-8920

Moorpark, California (8 A.M. to 5 P.M. PT)

Phone: (805) 553-5000 (Ext. 5591)

Fax: (805) 553-5515

TABLE OF CONTENTS

Important Warning and Safety Instructions	ii	4.0 - Maintenance	8
1.0 - Basic Principles of Operation	1	4.1 - Periodic Backwash	8
1.1 - Filtration - How Your Filter Works	1	4.2 - Periodic Inspection of Filters	9
1.2 - Backwash	2	4.3 - Draining the Filters	10
2.0 - Installation and Assembly	3	4.4 - Installation/Removal of Manway Cover	10
2.1 - Receiving and Inspecting	3	4.5 - Removal of Sand Media	11
2.2 - Locating the Filter	3	4.6 - Winterizing the Filter Tanks	12
2.3 - Setting Anchor Bolts	4	Appendices	13
2.4 - Install All Piping	5	Appendix A: Pressure Drop Curves	14
2.5 - Inspection of Components	5	Appendix B: Media Requirements	15
2.6 - Pressure Test System	6	Appendix C: Troubleshooting	16
2.7 - Media Installation	6	Appendix D: Backwash Log	17
3.0 - Start-up and Operation	7	Appendix E: Tank Specifications	18
3.1 - Backwash System	7	Appendix F: Tank Parts List	21
3.2 - Return Filters to Normal Filtration Mode	7		

IMPORTANT PUMP WARNING AND SAFETY INSTRUCTIONS



Important Notice:

This guide provides installation and operation instructions for the THS Series® Filters. Consult Pentair with any questions regarding this equipment.

Attention Installer: This guide contains important information about the installation, operation and safe usage of this product. This information should be given to the owner and/or operator of this equipment after installation or left on or near the filter.

Attention User: This manual contains important information that will help you in operating and maintaining this filter. Please retain it for future reference.

⚠ WARNING Before installing this product, read and follow all warning notices and instructions which are included. Failure to follow safety warnings and instructions can result in severe injury, death, or property damage. Call (800) 333-8125 for additional free copies of these instructions.

Consumer Information and Safety

These filters are designed and manufactured to provide many years of safe and reliable service when installed, operated and maintained according to the information in this manual and the installation codes referred to in later sections. Throughout the manual, safety warnings and cautions are identified by the “⚠” symbol. Be sure to read and comply with all of the warnings and cautions.



⚠ WARNING

THIS FILTER OPERATES UNDER HIGH PRESSURE

When any part of the filtration system, (e.g., closure, pump, filter, valve(s), etc.), is serviced, air can enter the system and become pressurized. Pressurized air can cause the top closure to separate which can result in severe injury, death, or property damage. To avoid this potential hazard, follow these instructions:

1. If you are not familiar with your filtration system:
 - a. Do NOT attempt to adjust or service without consulting your dealer, or a qualified filtration system technician.
 - b. Read the entire Installation & User's Guide before attempting to use, service or adjust the filtering system.
2. Before repositioning valve(s) and before beginning the assembly, disassembly, or any other service of the filtration system: (A) Turn the pump OFF and shut OFF any automatic controls to ensure the system is NOT inadvertently started during the servicing; (B) open the manual air bleeder valve; (C) wait until all pressure is relieved.
3. Whenever installing the filter closure FOLLOW THE FILTER CLOSURE WARNINGS EXACTLY.
4. Once service on the filtration system is complete FOLLOW INITIAL START-UP INSTRUCTIONS EXACTLY.
5. Maintain filtration system properly. Replace worn or damaged parts immediately, (e.g., closure, pressure gauge, valve(s), o-rings, etc.).
6. Be sure that the filter is properly mounted and positioned according to instructions provided.

IMPORTANT PUMP WARNING AND SAFETY INSTRUCTIONS

⚠ WARNING This filter must be installed in accordance with the all applicable local codes and ordinances. Improper installation could result in death or serious injury to users, installers, or others and may also cause damage to property.

Always disconnect power to the filtration system at the circuit breaker before servicing the filter. Ensure that the disconnected circuit is locked out or properly tagged so that it cannot be switched on while you are working on the filter. Failure to do so could result in serious injury or death to service person, users or others due to electric shock.

⚠ WARNING Do not operate the filter until you have read and understand clearly all the operating instructions and warning messages for all equipment that is a part of the filtration system. The following instructions are intended as a guide for initially operating the filter in a general filtration system installation. Failure to follow all operating instructions and warning messages can result in property damage or severe personal injury or death.

⚠ WARNING To reduce the risk of injury, do not permit children to use this product.

⚠ WARNING Never attempt to adjust any closures or lids or attempt to remove or tighten bolts when the system is pressurized. These actions can cause the closure to separate and could cause severe personal injury or death if they were to strike a person.

⚠ WARNING Never exceed the maximum operating pressure of the system components. Exceeding these limits could result in a component failing under pressure. This instantaneous release of energy can cause the closure to separate and could cause severe personal injury or death if they were to strike a person.



Thank you for purchasing your new THS Series® High Rate Sand Filter from Pentair. Your new filter vessel is the best that money can buy, with its ability to operate for years with a minimum amount of maintenance, as well as having excellent resistance to corrosion due to its all fiberglass construction. In this manual you will learn the basic principles on how your new filter operates, as well as how to install, operate, and maintain it. We suggest reading this manual through once to familiarize yourself with it before proceeding with installation and operation. Again, thank you for purchasing your high rate sand filter from Pentair.

1.0 Basic Principles of Operation

Your high rate sand filter is designed to operate for years with a minimum amount of maintenance when installed, operated and maintained in accordance with these instructions.

1.1 Filtration - How Your Filter Works

The basic principals of filter operation are as follows:

Dirty water enters the filter tank by being pumped under pressure through the influent pipe and is distributed across the top of the inner tank chamber through diffusers. The water is then forced downward through the sand filter bed. Dirt and debris is collected in the sand bed allowing clean water to pass through. The clean water then passes through the collection laterals and exits the filter through the effluent piping and is returned to the pool.

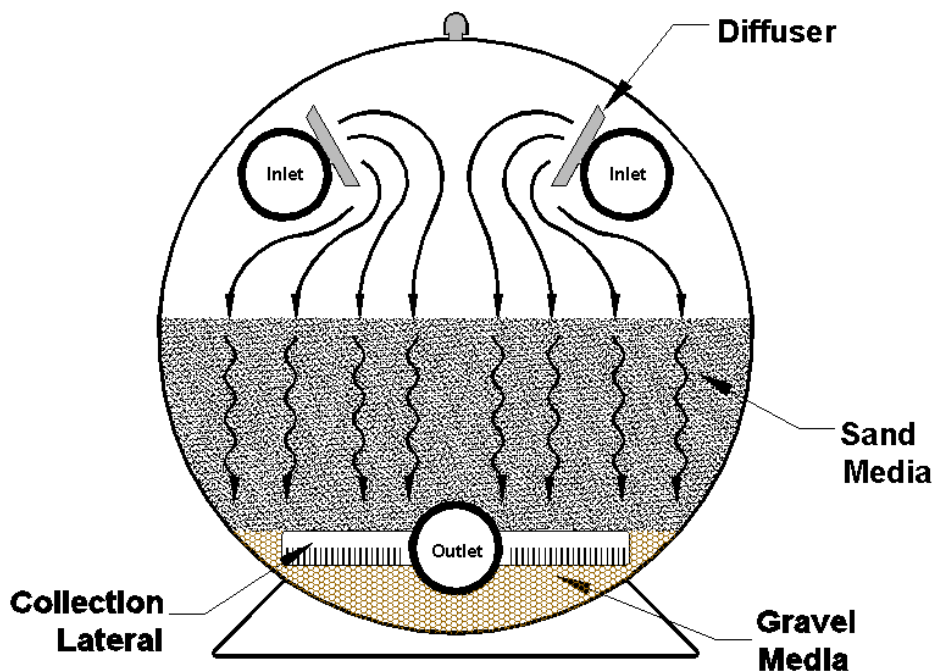

Tank Cross Section During Normal Filtration

The pressure in the THS Series® High Rate Sand Filter will increase and the flow of water through the filter will diminish as dirt accumulates in the filter. Eventually, the filter will become obstructed enough with dirt that it will become necessary to backwash the filter.

Please note that a filter removes suspended matter but it does not sanitize the pool. The pool water must be sanitized and the water must be chemically balanced for optimum water clarity. Your filtration system should be designed to meet your local health codes. Pool chemistry is a specialized area and you should consult your local pool service specialist for specific details.

1.2 Backwash

The basic principal of filter backwash is to reverse the flow of water through the filter. This will remove the dirt and debris trapped in the filter bed. For this principal to work properly a flow of 15-20 GPM per square foot of filter area should pass through the filter in the reverse direction. This will help to fluidize the sand bed, loosening any solids trapped or compacted in the bed, and then lifting the solids and transporting them out of the filter to waste. Usually a two to five minute backwash duration is all that is necessary to clean the filter. **Please note, it is absolutely necessary to have a large enough waste line to accommodate the backwash flow rate of the filter. A 6" waste line is recommended for all THS Series filter vessels.**

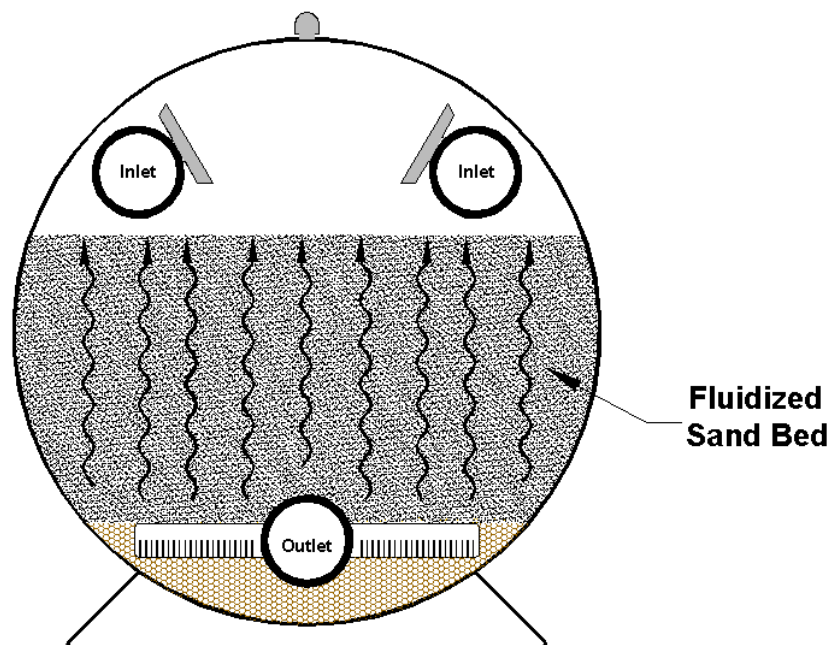

Tank Cross Section During Backwash Mode

2.0 Installation and Assembly

If you have purchased the vessel(s) with the optional face piping kit, please refer to documentation provided with the face piping kit.

2.1 Receiving and Inspecting

- Upon receipt of filter(s), check the filter pallet(s) and auxiliary cartons for any evidence of damage due to rough handling in shipment. If the THS Series® High Rate Sand Filter(s) or any filter components are damaged, NOTIFY FREIGHT CARRIER IMMEDIATELY.
- Verify that you have all equipment contained on the Packing List(s) and that there is no apparent damage to this equipment.

NOTE: BEFORE BEGINNING INSTALLATION, MAKE SURE PROPER SAFETY EQUIPMENT IS BEING USED.

2.2 Locating the Filter

- Prior to installing the filter(s), be sure to provide a PERMANENT LEVEL SLAB on which to mount the filter. Preferably the slab should consist of reinforced concrete poured in a form. Alternately, the filter(s) can be mounted on a platform constructed of concrete block or brick. The platform must be able to support the weight of the entire system (including media and water). DO NOT use sand to level the filter(s) or for pump mounting, as it will wash away.
- Position the concrete slab so that the instructions, warnings and the pressure gauges on the system will be visible to the operator. It should be positioned so that the piping connections, manway, and drain are convenient and accessible for servicing and winterizing. If possible, ensure that the filter(s) are positioned to accommodate any rough plumbing that may have been previously installed. Dimensions 'A' and 'B' in Figure 1 (next page) give the minimum filter to wall clearance in order to maintain a 6" minimum clearance between the tank and the wall (or other equipment). These are only given as minimum distance guidelines. Tanks may be set up at larger clearances if desired.

IMPORTANT: If a pre-glued diaphragm valve face piping kit has been purchased, it is very important that the center to center ("C-C") of the tanks be held to the dimension listed in Figure 1. Failure to do so may cause the piping kit not to fit properly.

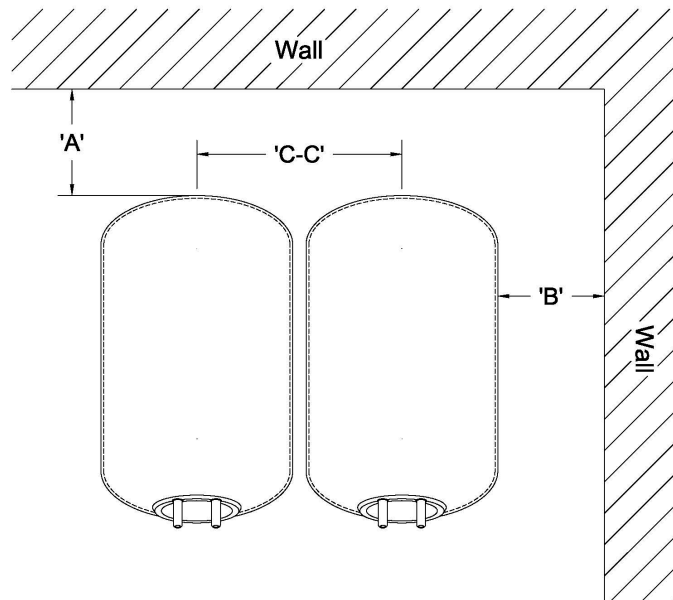

Figure 1

Model	"A" (in.)	"B" (in.)	"C-C" (in.)
THS3461	6	6	39
THS3484			
THS4272			46 1/4
THS4284			
THS4296			

- Ensure that the tank(s) are level, both across each pipe connection and from the influent pipe to the effluent pipe. For two tank systems, make sure the tanks are level to each other. If adjustments need to be made, loosen the nut underneath the saddles and adjust the saddle placement as needed. Be sure to tighten the nut after adjustment. If shimming is required to raise one end of the tank, be sure to use a non-compressible material placed under the bottom of the tank saddle.

2.3 Setting Anchor Bolts

NOTE: Local, county, and state codes may require that the tanks be anchored in a specific way. Please verify before proceeding with anchor installation.

- If the tanks are to be anchored to the slab, mark the holes when the tanks are in their desired position on the slab. Install anchors per manufacturer's specifications.

NOTE: Move the tanks aside before drilling for anchors. This may be necessary in order to comply with the anchor manufacturer's instructions, and will avoid damage to the tanks and/or saddles during anchor installation.

2.4 Install All Piping

NOTE: Unless the optional piping kit was purchased from the filter manufacturer, which provides the valves and piping to facilitate proper backwash and filtration operation, the filter manufacturer cannot accept responsibility for the design, installation, and operation of same. If an optional face piping kit was purchased, please refer to the appropriate manual provided with the kit for installation instructions.

- Install all piping to provide proper filtration and backwash operation. We recommend dry fitting all piping to ensure the proper fit.
- Once installed, all piping must be fully supported with bracing and hangers (by others) to prevent damage to the system from weight and vibration.

2.5 Inspection of Components

Before performing the initial start up of the filter system, inspect the tanks and components to ensure that no damage has occurred during the shipment of the vessel.

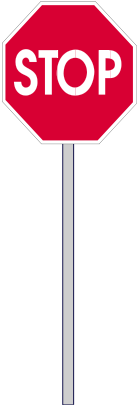

- **IMPORTANT! Check for loose, damaged, and missing laterals.** If they are loose, tighten them to hand tight, making sure that the slots are facing down. Missing or damaged laterals can result in returning the sand media from the filters to the pool, and must be replaced.

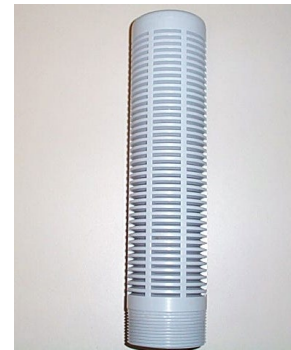

Lateral

- **IMPORTANT! Check for loose, damaged, and missing diffusers.** These are a key component in flow distribution in the tank. If they are loose, tighten them to hand tight. Missing or damaged diffusers should be replaced.



Diffuser

- **Check effluent piping grooved coupling connection** to make sure it has not become loose during shipping. If the coupling bolts have become loose, tighten them.

- **Make sure automatic air relief is attached properly.** This mechanism assists in bleeding off air, which may become trapped in the top of the tank. It is located on the effluent pipe near the top of the tank, and should be installed with the screen pointing up.



Automatic Air Relief Assembly

2.6 Pressure Test System

WARNING: Filters should never be tested or subjected to air or gas under pressure. All gases are compressible, and under pressure create a danger. Severe bodily injury or property damage could occur if the filter is subjected to air or gas pressure.

CAUTION: DO NOT exceed the maximum working pressure of the vessel (50 psi) during testing or operation.

NOTE: DO NOT install media prior to pressure testing the system.

- **Install the manway cover** (See section 4.4) and check that all piping connections, manual air relief cap, and media drain cap are tight.
- **Flood the system with water.** Make sure to bleed all air out of the tanks using the manual air relief cap.
- **Pressurize the system.** Caution: DO NOT exceed 50 psi.
- **Inspect all installed filtration equipment,** focusing on solvent welded connections, mechanical connections, and all tank penetrations.

NOTE: In the unlikely event that a leak is attributed to the vessel, consult the equipment supplier before proceeding with any tank repairs. Unauthorized repair attempts may void the factory warranty.

- **Drain the tank(s).** It is important to read section (4.3) for proper instructions.
- **Make repairs if necessary.** Before proceeding further, all repairs should be made at this time.

NOTE: Do not perform the following step until the system is pressure tested and all leaks are repaired (See Start-Up and Installation).

2.7 Media Installation

- **Consult Appendix B for media specifications.**
- **Partially fill the tank with water.** This will help prevent damage to the internal piping when installing the media.
- **If applicable, install the gravel media.** This layer should reach to the top of the effluent laterals and be level.
- **Install the sand media.** This layer should reach to approximately the centerline of the tank. The sand bed should be level and smooth. See pictures at right for example.



Above: Sandbed should be flat and smooth when sand is installed.

3.0 Start-up and Operation

The following steps should be followed in the order shown for initial start up of the filter system. Each section will be explained in more detail in the following pages.

1. Start system in backwash mode
2. Backwash each tank until clean
3. Start system in normal filtration mode

3.1 Backwash System

After the media is in place, reinstall the manway cover and fill the system with water. It is again important that all air in the tank(s) be bled out using the manual air relief fitting on the top of the tank(s). Once all of the air in the tanks is released, you may begin the initial backwash of the tanks. Each tank should be backwashed for at least 5 minutes to remove any dust or dirt from construction, as well as the “fines” in the media. When the wastewater coming from the backwashed tank runs clear and is free of grit, the tank has been fully backwashed. Repeat this for all tanks in the system. For some instances it may be necessary to repeat this backwash procedure several times in order to ensure that all “fines” have been removed.

Some things that should be noted during the backwash cycle:

- Adequate backwash flow (Approx. 15-20 GPM per square foot of filtration area)
- Quality of water flowing to waste (i.e. dirt, grit, etc.)

During a backwash the pressure through the system may differ from when it is in filtration mode. This is normal, however it is important to make sure that the pressure does not exceed the operating pressure of the tank.

3.2 Return Filters to Normal Filtration Mode

After backwashing is complete, run the system in normal filtration mode. Once this is done, you should take note of the following:

- **Inspect pool water returns for sand.** If the filter is returning sand to the pool, turn off the system immediately. Refer to the Appendix C for further information.
- **Verify pressure differential through the vessels is within an acceptable range.** Refer to Appendix A for pressure drops through the tanks only. Please be aware that depending on where the pressure readings are taken from and the design of piping system, the pressure drops through the system will be greater than what is shown in Appendix A. Please consult the water circulation system designer for more details.
- **Note the pressure differential over the now clean filter system.** If the system is filtering within an acceptable pressure loss range, with the maximum pressure not to exceed 50 psi, then the filter(s) can be considered clean. Please note the differential pressure, as it may be needed later to determine backwash schedules. See section 4.1 for more details. Appendix D, which will be referred to later, provides a chart to log these pressures into for future reference.

Congratulations, your THS Series® High Rate Sand Filter is now ready to filter water. Please read the next section on Maintenance to learn how to care for your new filter tank(s).

4.0 Maintenance

Although the “Smoothie” filter vessel is designed to operate for many years with little maintenance, there are some items that should be periodically inspected. In certain situations, periodic maintenance may be necessary. The following is a list of items that should be checked periodically, as well as some maintenance items, which may need to be performed.

IMPORTANT: When performing maintenance, which requires entry into the tank, VERIFY that all water sources to the tank are isolated and locked and tagged out before entering tank. This is a confined space situation and all rules and safety guidelines set forth by OSHA regarding such situations should be strictly followed.

4.1 Periodic Backwash

If you have purchased the vessel(s) with the optional face piping kit, please refer to documentation provided with the face piping kit.

The tanks need to be backwashed when the sand bed becomes clogged with debris from the pool. There are a few different ways to determine when backwashing should occur. The following are the most common methods, however depending on piping design; backwash frequency can be determined in a different manor if desired.

- **Pressure Differential.** When tanks become dirty, the pressure through them increases. During the initial pressure test of your tank(s), the pressure through the clean filter(s) should have been noted and recorded. This is your clean filter pressure differential. When the filter pressure increases by 10 psi above this clean filter pressure, the tank(s) should be backwashed.
- **Time Schedule.** If desired, the system can be backwashed based on a time schedule, such as once a week. This is up to the user as to when to backwash the tank(s), however it is recommended that backwashing occur often enough so the tanks don't become too clogged. This may be especially necessary after periods of increased bather load.

When backwashing, it is important that there is:

- **Sufficient Backwash Time.** It is recommended to backwash each tank for at least 3 to 5 minutes or until waste water runs clear.
- **Sufficient Backwash Flow Rate.** The flow going through the tank in backwash mode must be in the range of 15 to 20 GPM/ft² in order to accomplish an adequate backwash.

NOTE: It may be necessary in some instances to backwash the tanks more than once to achieve a clean sand bed.

It is recommended that the influent and effluent pressures be recorded at the time of each backwash. Appendix D has been provided to record these pressures. This information may be useful in determining backwash frequency. It may also be useful in troubleshooting some types of problems.

4.2 Periodic Inspection of filters

Part of the maintenance schedule that is suggested for these tanks is to check certain areas of the filter tanks for signs of possible problems. Below are some key areas, which should be inspected regularly.

- Inspect Media Bed.** The sand media bed should be inspected on a yearly basis, or whenever the system is drained for maintenance. The sand bed should be smooth and level. A difference in sand elevation between the highest and lowest points of the bed that is 3" or more may indicate a problem which may require further investigation. This may indicate that there may be damaged internal tank components such as diffusers or laterals.



Above: Typical sand beds after draining tanks. Note the smooth, flat sand bed. There are no signs of trenching or erosion.

Below: The sand beds shown below may indicate a problem. Note the trenches and erosion of the media, which has developed.



- Inspect tanks for leaks.** The system should be inspected periodically for leaking around the influent/effluent piping penetrations, drain port, manual air relief fitting, and on the outside shell of the tanks. A quick visual sight inspection is all that is needed to accomplish this. **In the unlikely event that a leak is attributed to the vessel, consult the equipment supplier before proceeding with any tank repairs. Unauthorized repair attempts may void the factory warranty.**
- Take note of system parameters (Influent/Effluent pressure).** This is especially important if you are not using an automatic backwash control system. These parameters are prime indicators as to whether or not a backwash cycle needs to be run. They should be checked every couple of days, particularly after periods of increased bather load.

4.3 Draining the Filters

Some maintenance may require the THS Series® High Rate Sand Filters to be drained of all water. To accomplish this you must:

- **Make sure that the system is shut down.** Isolate all water sources from the filter(s).
- **Remove the drain cap located on the bottom of the front of the tank.** See figure below for location.
- **Open the manual air relief on top of the tank.** This will allow the water to drain faster as well as to prevent the creation of a vacuum in the tank.

NOTE: A vacuum condition in the tanks can damage the tanks and possibly other components in the filter system.

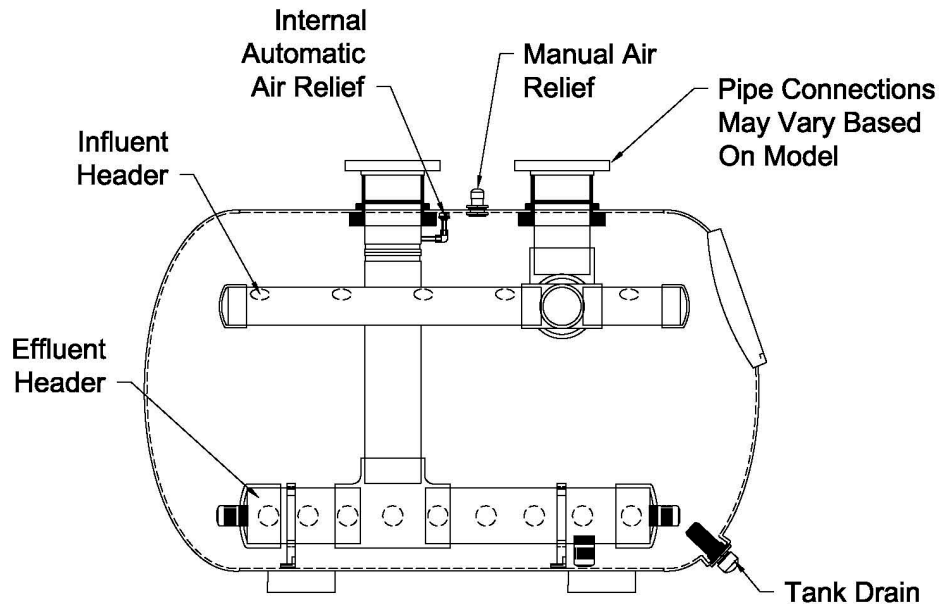

Figure 2-Drawing is for reference only, actual tank may vary.

- **Replace Caps when water is drained.**

4.4 Installation/Removal of Manway Cover

NOTE: It is important that the manway yokes never be removed during operation of the tanks. The tanks should be drained before removing manway cover.

4.4.1 Removal:

- **Drain the tanks.** See section 4.3 for instructions.
- **Remove one yoke bolt and yoke.** This will require a 1 1/8" wrench. Loosen the second bolt, but do not remove the second yoke.
- **Remove cover from tank.** Rotate remaining yoke 90° and push cover into tank. Turn the cover so that it will pass through the manway opening and remove the cover. Make sure the manway gasket is with the cover. If not, look for it on the manway opening or inside the tank.

*Manway cover may differ from picture below



Gasket ring

4.4.2 Installation:

- **Ensure there are no tools, construction materials, or foreign objects in the tank.**
- **Clean the sealing surfaces of the cover and manway opening.** Make sure they are free of dirt and debris.
- **Install gasket ring on manway cover.** See picture at right for correct location.
- **Maneuver the cover back into the tank so it fits back in the manway opening.** Follow removal directions in reverse order.
- **Install yokes, bolts, and washers.** Make sure the yokes are in the proper locations. See picture at right.
- **Snug yoke bolts.** Tighten bolts one full turn past hand tight. If manway leaks during refilling of system, tighten bolts in quarter turn increments until leak stops. After filter is at operating pressure, yokes will be loose due to internal pressure. Snug bolts until yokes no longer move. **DO NOT exceed 15 ft/lbs of torque.**



Correct yoke orientation

4.5 Removal of Sand Media

The sand media in the filter should be removed when:

- **Media bed has become contaminated.** The media bed can become contaminated due to the introduction of an unwanted substance into the water, such as fecal matter, chemicals, etc. While the filters will take out the particulate matter of the contaminate and prevent it from returning to the body of water, the contaminate will become embedded in the media. This can affect pool chemistry.
- **THS Series® High Rate Sand Filters need to be moved from their current location.** While these tanks are designed to withstand internal pressure, they are not designed to be transported with the added weight of the media inside of them. It is therefore necessary to remove as much media as possible before relocating the filters.
- **Inspections/repairs need to be made to inside of tank or internal components.** In order to reach certain components or areas of the tank, the sand has to be partially or removed. These areas include laterals, effluent piping, media drain assembly, inside walls of the filter.

If you need to remove the media the tanks must be drained first, see Draining Filters section. After draining the filters, remove the manway cover (see Section 4.4.1). Removal can be done by a variety of means, from using an ordinary shovel, to adding water to the sand and removing the slurry with a pump truck. **It is important that if using shovels or other devices with edges, corners, etc. that care be taken to not scratch the inside walls of the tank.** The inside walls are coated with a material that protects the water from exposure to the fiberglass walls of the tanks.

Remove only as much material as required to perform any maintenance operations. If all of the sand needs to be removed for the purpose of replacement due to contamination, be sure to rinse out the tank with clean water. It may be necessary to backwash the tank(s) after rinsing to remove sand stuck in the laterals. Follow the backwash procedures outlined earlier in this section.

4.6 Winterizing the Filter Tanks

In areas where the tanks will not be in service during the winter months, or where tanks may see freezing or below freezing temperatures, it is recommended that the tank(s) be winterized. This will protect the tank(s) from being damaged due to ice expansion. Some items that may be damaged due to this may include internal piping, internal components, and tank walls. Below are the steps that should be performed when winterizing the tank(s):

- Thoroughly backwash each filter to remove foreign contaminants from the filter bed prior to draining the system
- Shut off all electrical power to the filter system.
- Drain the tanks by removing the drain plug from the tank (See Section 4.3). Opening the manual air relief valve cap will help in allowing the water to drain out of the filters, as well as preventing a vacuum condition from occurring.
- When the water is drained from the system, drain all of the water in the backwash line.
- Loosen any flanges in low-lying sections of piping to completely drain the system of water.
- Store any plugs/caps removed near the filter and mark all flanges that have been loosened so that they may be reinstalled and tightened at time of start up.

APPENDICES

APPENDIX A	PRESSURE DIFFERENTIAL CURVES
APPENDIX B	MEDIA REQUIREMENTS
APPENDIX C	TROUBLE SHOOTING
APPENDIX D	BACKWASH LOG
APPENDIX E	GENERAL TANK SPECIFICATIONS
APPENDIX F	TANK PARTS

APPENDIX A: Pressure Drop Curves

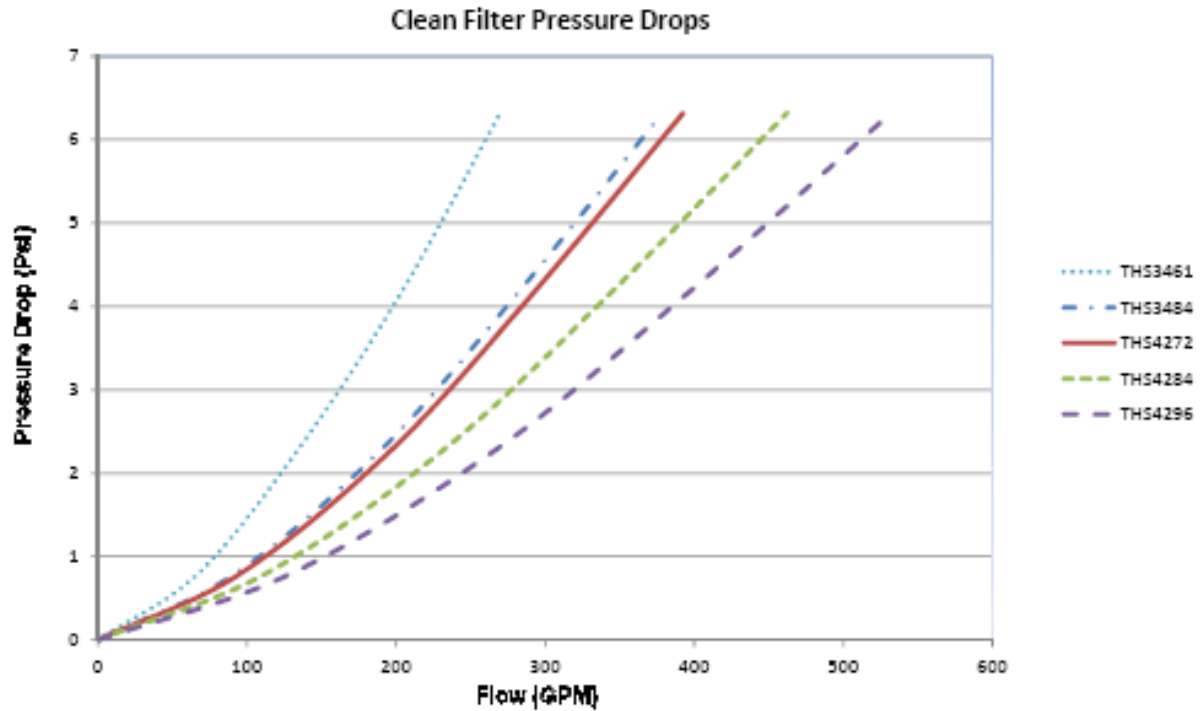

NOTE:

1. The charts are based on using NSF approved #20 sand in the filters. Variation in sand media may affect pressure differential values.
2. These charts are for pressure drop through the tanks only. Depending on the location of the pressure gauges, there will likely be additional contributors to the pressure differential, such as valves, fittings, etc.
3. For design purposes a filter pressure drop of 6.5 psi at 20 gpm per sq. ft. is recommended.

APPENDIX B: Media Requirements

Filter Model	Filter Area (Ft ²)	*Total Media Requirement (Ft ³)	Sand Media (Ft ³)	Gravel Media (Ft ³) (Optional)	Freeboard Height (in.)	Sand Bed Depth (in.)	Gravel Depth (in.)
THS3461	13.5	15.5 (1550 lbs.)	12.5 (1250 lbs.)	3.0 (300 lbs.)	7 1/2	9	8 5/16
THS3484	19.0	19.5 (1950 lbs.)	13.5 (1350 lbs.)	6.0 (600 lbs.)			
THS4272	19.7	26.0 (2600 lbs.)	21.0 (2100 lbs.)	5.0 (500 lbs.)	9 1/2	15	7 1/2
THS4284	23.2	30.0 (3000 lbs.)	24.0 (2400 lbs.)	6.0 (600 lbs.)			
THS4296	26.7	35.0 (3500 lbs.)	28.0 (2800 lbs.)	7.0 (700 lbs.)			

Media Type	Media Size	Specific Gravity	Uniformity Coefficient
Pea Gravel	1/4" - 1/8"	Greater than 2.5	Less than 1.5
Sand	#20 Standard .018"-.022" (.45mm-.55mm)	2.65	Less than 1.5

NOTE:

1. All gravel and sand should be washed and screened. It should contain less than 1% of loam, clay, sand, shells, dirt organic impurities or other foreign matter.
2. It is recommended that all media used be NSF approved.

*-If preferred, sand media can be used to satisfy total media requirements by substituting the equivalent weight of the gravel with that of sand.

APPENDIX C: Troubleshooting

Problem	Possible Cause	Solution
Source water not sufficiently clear	1. Water chemistry not in balance	Maintain pool chemistry. Consult pool service technician
	2. Incorrect media installed	Verify media size with media vendor. Consult Appendix B of this manual for proper media sizing. If the media is the incorrect size, replace with proper media.
	3. Filter system not being backwashed properly	The tank(s) may not have been backwashed enough upon initial start-up. Repeat the backwash procedure for initial start-up (see Start-up and Operation section). Backwash each tank twice to ensure that the media bed is clean and free of debris.
	4. Rate of flow in excess of 20 GPM/ft ² of filter area	Adjust the flowrate through the filters. These filters are designed to operate at a maximum of 20 GPM/ft ² . If flow rates are in excess of this, the media bed will not perform as designed.
	5. Inadequate turnover rate	The turnover rate is the amount of time it takes the filters to pass the entire volume of the pool through the filter system. Filtration systems for pools are typically designed to operate at a turnover rate of 1-6 hours typically depending on the application and appropriate codes. If the filter system is filtering the water too slow, dirt and debris can build up faster than the water is cleaned. The flow through the filters may need to be increased. Consult the manufacturer before changing the filtration parameters.
Filtration media being discharged into the filtered body of water	1. Incorrect media installed	Verify media size with media vendor. Consult Appendix B of this manual for proper media sizing. If the media is the incorrect size, replace with proper media.
	2. Damaged effluent piping/lateral	The tank(s) must be drained of water (see Maintenance section) and all media removed. Once this is done, an inspection of all internal piping should be performed. If any laterals are broken, cracked, or missing, they should be replaced. If the main effluent pipe in the tank is cracked, consult the manufacturer for repairs.
High filtration pressure differential	1. Filter system not being backwashed properly	The tank(s) may not have been backwashed enough upon initial start-up, backwashes may be too infrequent, or there may not be enough backwash flow. Check the backwash flow rate on the waste pipe to verify that enough backwash flow is present. A minimum of 15 GPM/ft ² of filtration area is recommended.
	2. Impacted sand bed	Sometimes the sand media may become compressed, which inhibits the flow of water through it. If an impacted sand bed is suspected, the tanks should be drained and the media should be loosened by turning over the top 6"-10" of sand. After this, a backwash cycle should be run before returning the filter to filtration mode.
Excessive sand media being lost to waste drain	1. Backwash flow rate is too high	If the flow rate is too great, it will force some of the sand media out through the diverters and into the waste drain. Reduce the flowrate slightly to the filters when performing a backwash.
	2. Incorrect media installed	Verify media size with media vendor. Consult Appendix B of this manual for proper media sizing. If the media is the incorrect size, replace with proper media.
Leak at manual air relief, manway, or tank drain port	1. Improperly tightened assembly	With the pump off, isolate the tanks from the system and relieve the tank of any pressure using the manual air relief valve. If leak has occurred in an area which is below the water level in the tank, drain the tank until water line is below the leak (see Maintenance section). Remove the assembly and inspect the sealing surfaces for dirt and debris. Clean all sealing surfaces. If the assembly is still in usable condition, replace the assembly and pressure test the system (see Start-up and Operation section). If the assembly appears broken or defective, replace with a new factory part (see Appendix X for part number). After replacement pressure test the system before restoring it to normal filtration mode.
	2. Dirt or contamination on sealing surface	
	3. Damaged part	

APPENDIX E: Tank Specifications

THS3461 2-HEAD SMOOTHIE FILTER

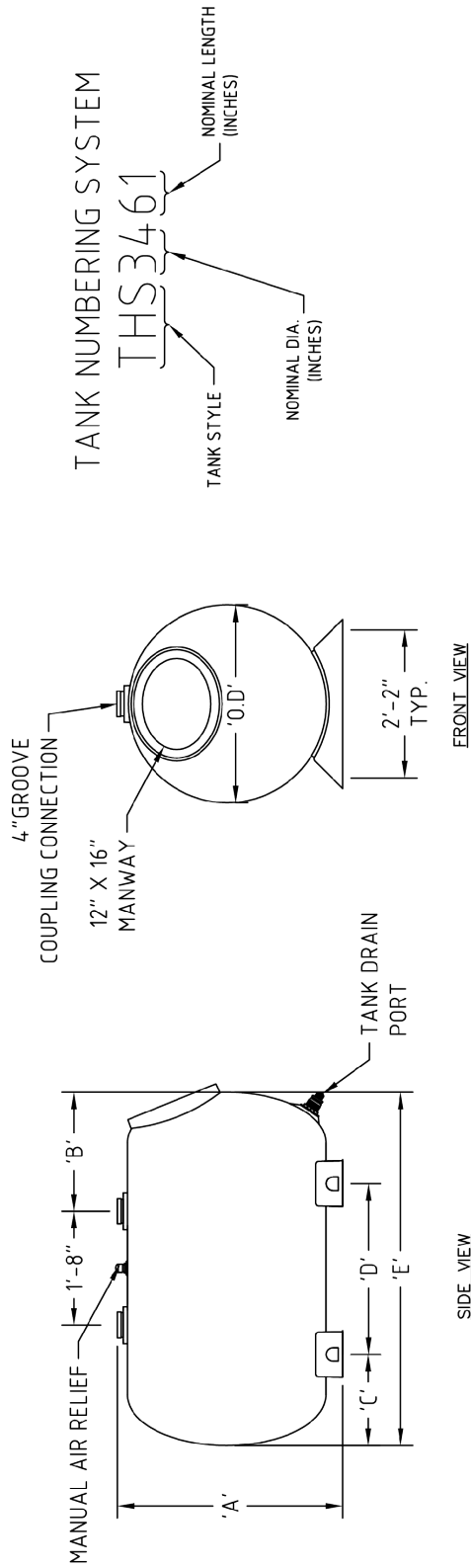

Model	Max Flow Rates				Media Requirements							Tank Dimensions							
	Filter Area (ft ²)	Flow Rate @ 10 (GPM) (GPM/ft ²)	Flow Rate @ 15 (GPM/ft ²) (GPM)	Flow Rate @ 20 (GPM/ft ²) (GPM)	Sand Media (ft ²)	Gravel Media (ft ²)	Total Media (ft ²)	Freeboard Height (in.)	Sand Bed Depth (in.)	Gravel Depth (in.)	Operating Weight (lbs.)	Shipping Weight (lbs.)	"A" in.	"B" in.	"C" in.	"D" in.	"E" in.	"O.D." in.	
THS3461	13.5	135	202.5	270	12.5 (1250 lbs.)	3.0 (300 lbs.)	15.5 (1550 lbs.)	7 1/2	9	8 5/16	3496	530	39 1/2	21	16	30	61 7/8	34 5/8	

THS3484 / THS4272 / THS4284 / THS4296 2-HEAD SMOOTHIE FILTER

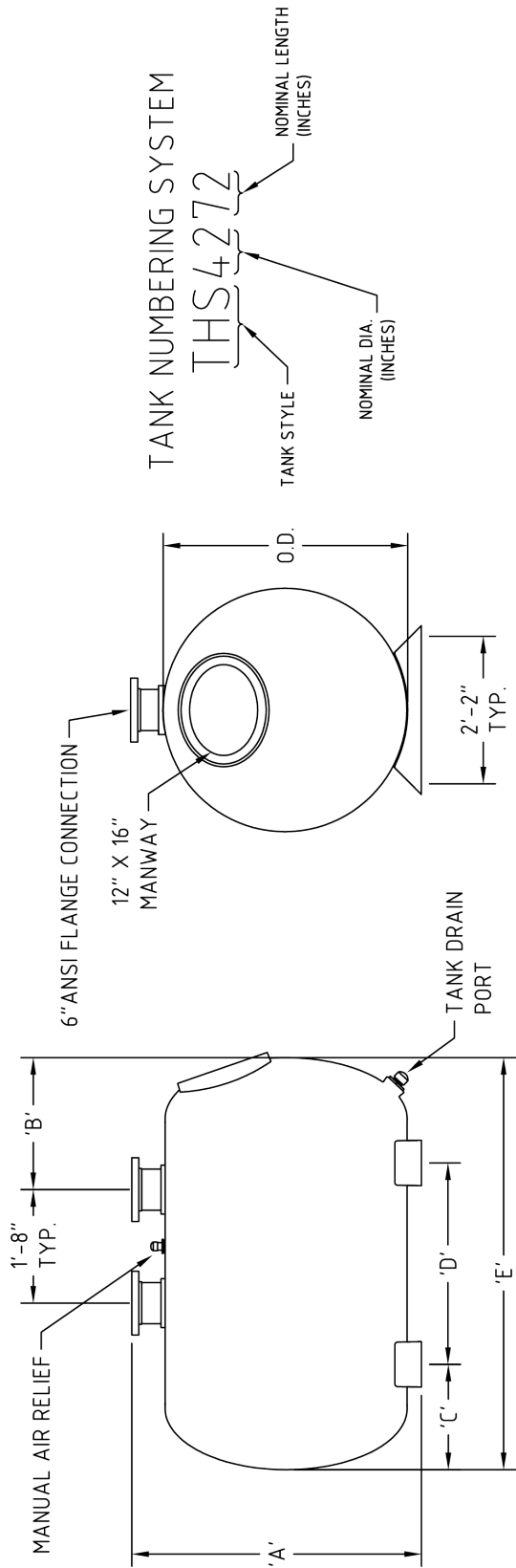

Model	Max Flow Rates			Media Requirements						Tank Dimensions							
	Flow Rate @ 10 GPM/ft ² (GPM)	Flow Rate @ 15 GPM/ft ² (GPM)	Flow Rate @ 20 GPM/ft ² (GPM)	Sand Media (ft ²)	Gravel Media (ft ²)	Total Media (ft ²)	Freeboard Height (in.)	Sand Bed Depth (in.)	Gravel Depth (in.)	Operating Weight (lbs.)	Shipping Weight (lbs.)	"A" in.	"B" in.	"C" in.	"D" in.	"E" in.	"O.D." in.
THS3484	190	285	380	13.5 (1350 lbs.)	6.0 (600 lbs.)	19.5 (1950 lbs.)	7 1/2	9	8 5/16	4602	630	45	21	24 5/8	35 1/4	84 7/8	34 5/8
THS4272	197	296	394	21.0 (2100 lbs.)	5.0 (500 lbs.)	26.0 (2600 lbs.)				5684	700			18 7/8		72 7/8	
THS4284	232	348	464	24.0 (2400 lbs.)	6.0 (600 lbs.)	30.0 (3000 lbs.)	9 1/2	15	7 1/2	6719	780	52 1/4	23 1/4	24 7/8	35 1/4	84 7/8	42 5/8
THS4296	267	401	534	28.0 (2800 lbs.)	7.0 (700 lbs.)	35.0 (3500 lbs.)				7724	870			30 7/8		96 7/8	

APPENDIX F: Tank Parts List

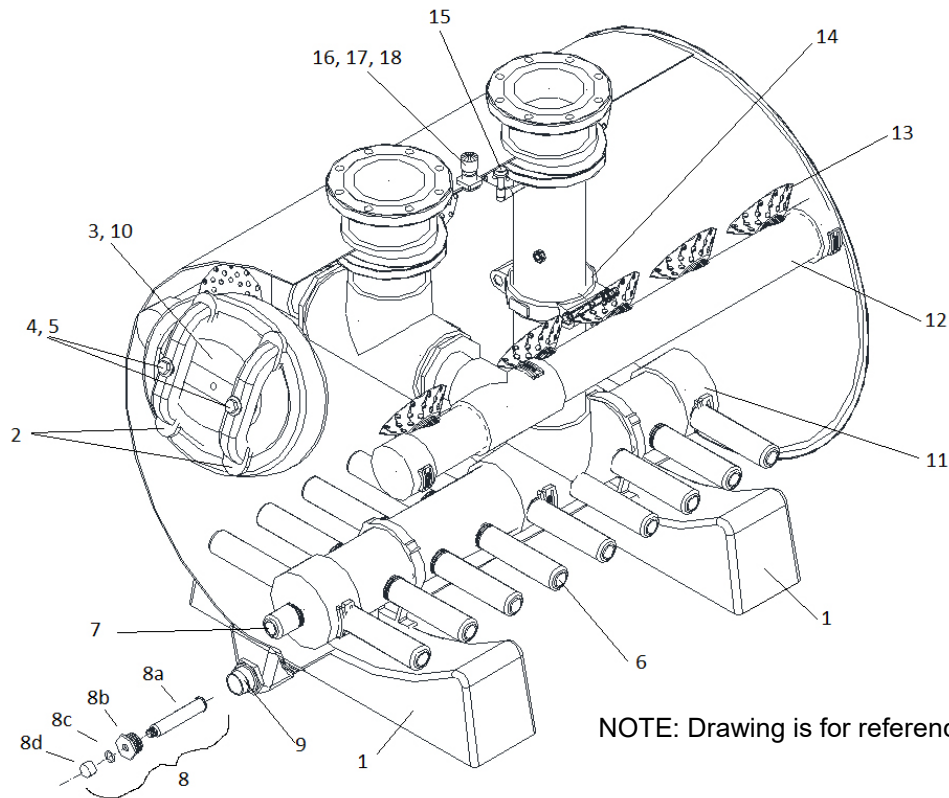

NOTE: Drawing is for reference only.

Ref #	Part Number	Description	Tank Used On	Quantity
1	B4848BL-32	Tank Saddle, Black	All	2
2	B4856	Yoke, Dog (Manway)	All	2
3	B4852A-N	Glass Filled Manway Cover (Black)	All	1
4	94910	HHMB, 3/4" x 4" T316 S/S	All	2
5	B4860	3/4" Flat Washer, T316 S/S	All	2
6	B4804	10" Effluent Lateral	THS3461	14
			THS3484	20
			THS4272	18
			THS4284	24
			THS4296	28
7	B4803	3-1/2" Effluent Lateral	THS3461 - THS3484	2
			THS4272 - THS4296	3
8	B4980	Media Dump Assembly	All	1
8a	B4983	6" Lateral, 1/2" NPT	All	1
8b	B4982	1-1/2" Pipe Plug	All	1
8c	B4698	O-Ring	All	1
8d	B4984	1/2" Pipe Cap	All	1
9	B4981	1-1/2" NPT Tank Adapter	All	1
10	B4951	Manway O-Ring	All	1
11	Call	Effluent Manifold w/o Laterals	Call	1
12	Call	Influent Manifold w/o Laterals	Call	1
13	B4806	Shower Head Diffuser	THS3461	8
			THS3484	10
			THS4272	10
			THS4284	12
			THS4296	14
14	B4570	4" Grooved Coupling Assembly	THS3461 - THS3484	1
	B4572	6" Grooved Coupling Assembly	THS4272 - THS4296	1
15	B4578	Automatic Air Relief Assembly	All	1
16	B4974BAN	1/2" Manual Air Relief Cap	All	1
17	B4970BAN	1/2" Threaded Nipple	All	1
18	B4979BAN	1/2" Bulkhead Fitting	All	1



1620 HAWKINS AVE., SANFORD, NC 27330 • (919) 566-8000
10951 WEST LOS ANGELES AVE., MOORPARK, CA 93021 • (805) 553-5000

All indicated Pentair trademarks and logos are property of Pentair. Third party registered and unregistered trademarks and logos are the property of their respective owners.

© 2024 Pentair. All rights reserved. WWW.PENTAIR.COM



P/N 155696 REV. L 1/18/24