

THS SERIES[®]

HIGH PERFORMANCE HORIZONTAL SAND FILTERS

For commercial swimming pools and other water applications and filters up to 27 sq. ft. of filtration area. Various sizes and configurations to fit almost any body of water.

Pentair has a state-of-the-art horizontal sand filter unlike any other on the market. The THS Series filter is an NSF-approved 50 psi rated tank with flow rates up to 535 gpm in a single tank. The filter shell is manufactured from a long-lasting composite laminate that makes winding unnecessary. A special coating gives the THS Series filter a smooth and attractive finish. An interior coating protects wet surfaces.

STANDARD FEATURES

- Manway in front for easy access and smaller footprint.
- 34" diameter tanks will fit through standard doorway.
- Optional manual, semi-automatic, or fully automatic backwash systems.
- Accessible drain.
- Influent manifold distribution to help prevent clogging.
- Single-bolt saddles for easy leveling.
- NSF Listed.



THS SERIES HIGH PERFORMANCE HORIZONTAL SAND FILTERS

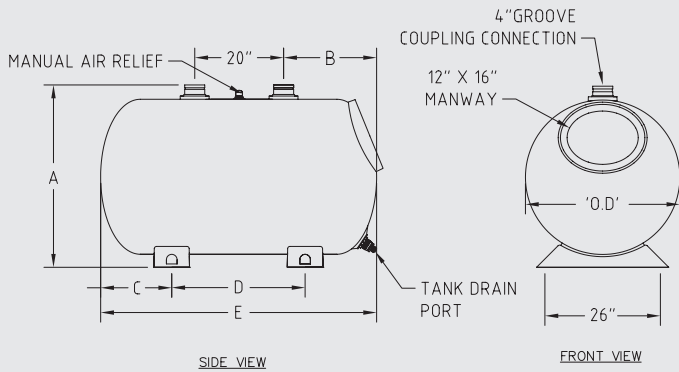

THS 3461 Only

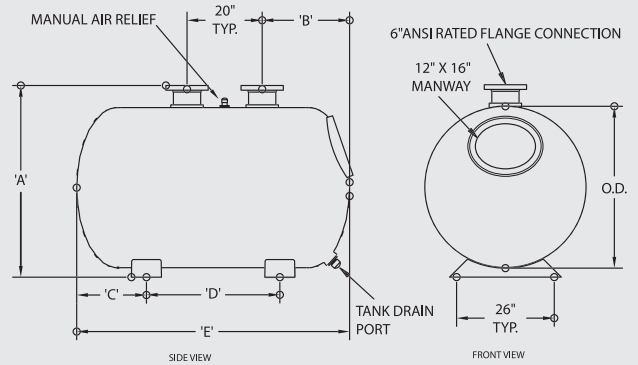

THS 3484, THS 4272, THS 4284, THS 4296

MATERIALS AND DESIGN

Tanks

- Construction
 - Multi-layer engineered fiberglass crafted of chopped glass and directional roving in an isophthalic polyester matrix.
- Operating Pressure
 - Capable of withstanding 50 PSI internal pressure.

Internals

- Headers
 - One influent header is fitted with sufficient distributors to properly distribute incoming flow evenly across the sand bed surface. An additional effluent header is supplied with sufficient laterals equally distributed not less than 12 inches below the filtering sand bed.
 - Laterals are 2 3/8" x 10" with 2" NPT connections and constructed of ABS plastic with molded 'V'-groove slots.

Tank Base

- Support Bases
 - Tanks feature ABS saddle style support bases for filter body, capable of rotation for leveling purposes.

Operation / Performance

- Flow Rate
 - NSF Listed for 5 to 20 GPM per square foot of filter area.
- Maximum Limits
 - Working pressure 50 PSI max. Continuous water temperature 125° F.
- Sand Media
 - #20 white quartz silica sand. Effective size 0.45-0.55 mm.
- Safety provisions
 - Each tank features an automatic and manual air release system fabricated of non-corrosive materials.

Controllers - Must Be Used With Diaphragm Valve Kits

156850	Single THS CA100 Auto-backwash controller for single tank system
156800	Dual THS CA100 Auto-backwash controller
156400	Single THS CM200 Semiautomatic controller 6 in. FP
156450	Dual THS CM200 Semiautomatic controller 6 in. FP
CS400-01	CS400 backwash controller for single tank system
CS400-02	CS400 backwash controller for dual tank system

FILTER ORDERING INFORMATION

Product	Model	Description
143461	THS3461	THS 34 in. x 61 in.
143484	THS3484	THS 34 in. x 84 in.
144272	THS4272	THS 42 in. x 72 in.
144284	THS4284	THS 42 in. x 84 in.
144296	THS4296	THS 42 in. x 96 in.



FILTER PERFORMANCE

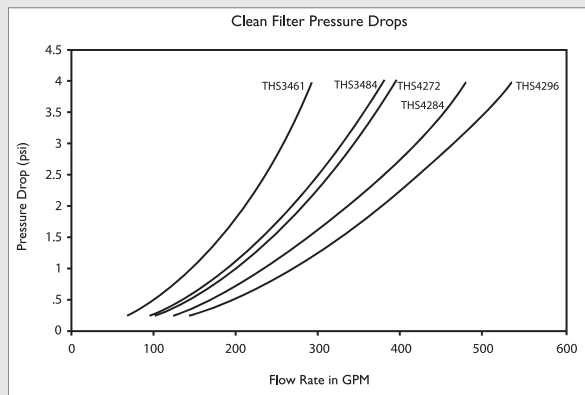

Filter Accessories Information

155700	THS Single Tank Manifold Kit w/ Butterfly Valves	156150	Flowmaster Saddle Kit
155720	THS Dual Tank Manifold Kit w/ Butterfly Valves	156100	Temperature Probe Kit
155701	THS Single Tank 6 in. FP Kit w/ Diaphragm Valves	155702	THS3461 Single Tank Manifold Kit w/ Butterfly Valves
155721	THS Dual 34 in. dia. 6 in. FP Kit w/ Diaphragm Valves	155703	THS3461 Single Tank Manifold Kit w/ Diaphragm Valves
155730	THS Dual 42 in. dia. FP Kit w/ Diaphragm Valves	155722	THS3461 Dual Tank Manifold w/ Butterfly Valves
155800	WA-KIT Wedge Anchor Kit	155723	THS3461 Dual Tank Manifold w/ Diaphragm Valves
155850	BVA-KIT 1/2 in. Ball Valve Adapter Kit for manual air relief	140325	Adder Kit for Third THS Filter

Tank dimensions/media requirements

Model	Maximum Flow Rates				Media Requirements		
	Filter Area (ft ²)	Flow Rate@ 10 GPM/ft ² (GPM)	Flow Rate@ 15 GPM/ft ² (GPM)	Flow Rate@ 20 GPM/ft ² (GPM)	Sand Media (cu. ft.)	Gravel Media (cu. ft.)	Total Media (cu. ft.)
THS3461	13.5	135	203	270	12.5 (1,250 lbs.)	3.0 (300 lbs.)	15.5 (1,550 lbs.)
THS3484	19.0	190	285	380	13.5 (1,350 lbs.)	6.0 (600 lbs.)	19.5 (1,950 lbs.)
THS4272	19.7	197	296	394	21.0 (2,100 lbs.)	5.0 (500 lbs.)	26.0 (2,600 lbs.)
THS4284	23.2	232	348	464	24.0 (2,400 lbs.)	6.0 (600 lbs.)	30.0 (3,000 lbs.)
THS4296	26.7	267	401	534	28.0 (2,800 lbs.)	7.0 (700 lbs.)	35.0 (3,500 lbs.)

Model	Media Requirements					Tank Dimensions					
	Feeboard Height (in.)	Sand Bed Depth (in.)	Gravel Depth (in.)	Operating Weight (lbs.)	Shipping Weight (lbs.)	A (in.)	B (in.)	C (in.)	D (in.)	E (in.)	O.D. (in.)
THS3461	7½	9	8⅝	3,500	530	39½	21	16	30	62	35
THS3484	7½	9	8⅝	4,600	630	45	21¼	24⅝	35¼	85	35
THS4272	9½	15	7½	5,700	700	52¼	23¼	18⅞	35¼	73	43
THS4284	9½	15	7½	6,700	780	52¼	23¼	24⅞	35¼	85	43
THS4296	9½	15	7½	7,700	870	52¼	23¼	30⅞	35¼	97	43

THS SERIES®

HIGH PERFORMANCE HORIZONTAL SAND FILTERS

ENGINEERING SPECIFICATIONS

The filter system shall be a model _____ as manufactured by Pentair, and shall be approved by the National Sanitation Foundation (NSF).

The system shall contain _____ high rate type filter tanks, with each tank containing _____ square feet of filter area totaling _____ square feet of effective filtration area. The system shall have the capacity of filtering _____ gpm when filtered at _____ gpm per square foot. Each tank shall be of the horizontal type, _____ inch inside diameter and _____ inches long.

The vessel(s) shall be constructed of multi-layer fiber glass. Layers shall consist of a combination of chopped glass and woven roving in an isophthalic-polyester matrix. The vessel shall be assembled from one side shell and two domed ends which shall be joined with an adhesive and reinforced with FRP layup. The vessel(s) shall be capable of with standing 50 psi internal pressure. Alternate construction methods shall not be acceptable.

Vessels shall be provided with ABS saddle style support bases with a means of rotating the saddle for leveling purposes. The use of adhesive to hold the saddle to the vessel is not acceptable.

The wetted surface shall be a modified polyester gel coat (GC). The gel coat shall be a modified polyester gel coat equivalent to a Cook gel coat 943-AN-023 with a thickness of no less than 10 mils.

The external surface shall be smooth in appearance and be free of cracks or other defects. The exterior surface shall be supplied with an all weather coating. Coating shall be urethane based with UV inhibitors. The surface coating shall be almond colored.

Each tank shall have one influent header fitted with sufficient distributors to properly distribute incoming flow evenly across the sand bed surface and one effluent header with sufficient laterals equally distributed not less than 12 inches below the filtering sand bed with a total effective slot area such that the average velocity through the slots will not exceed 6 feet per second at the design flow rate. Both headers shall be fabricated of schedule 80 PVC and all distributors and laterals shall be threaded and replaceable. The laterals shall be 2 3/8 inch diameter by 10 inches long with 2" NPT connections and constructed of ABS plastic with molded 'V'-groove slots. Laterals with machined or cut slots shall not be accepted. Laterals shall be threaded at right angles into the header pipe.

Exterior influent and effluent pipe connections shall be 6" VanStone-style flanges

Each tank shall have a 12 inch by 16 inch access manhole with yokes, molded cover, o-ring, and T316 stainless steel hardware.

The system shall be designed for installation against a back or side wall with all servicing accessible without moving tank(s). When the system is off, the tank(s) must remain full of water and not allow water to gravity drain back to the source in order to prevent disturbance of the sand bed. Each tank shall have an automatic and manual air release system and shall be of non-corrosive materials. A sufficient quantity of #20 U.S. grade clean crystal silica sand to cover filter elements with a minimum 12 inch sand bed shall be furnished and installed into each tank and shall be free of limestone or clay. The following is an acceptable gradation for this media:

#20 SILICA SAND

Effective size: 0.45 mm (0.018 in.) to 0.55mm (0.022 in.)

Uniformity coefficient: less than 1.5

Grain Sphericity: GRTR 0.7

The filter vessel shall carry a ten (10) year limited warranty covering defects in material and workmanship, the first three years of which shall not be pro-rated.

For Single Tank System Diaphragm Valve Face Piping Kits

- The system, including external piping, shall be fully solvent-welded. System shall be supplied with media dump port and anchor setting template.
- The backwash procedure must be accomplished by backwashing using water from the pool in reverse flow through the filter to the waste line.
- The influent, effluent and waste manifolds shall be constructed of schedule 80 PVC piping and fittings. The system shall include (2) three-way hydraulically operated diaphragm valves to direct the flow during the backwash cycle.

For Two Tank System Diaphragm Valve Face Piping Kits

- The system, including external piping, shall be fully solvent-welded. System shall be supplied with media dump ports and anchor setting templates.
- Each tank in system shall be capable of being backwashed individually using filtered water from the remaining tanks. The common method of backwashing by using raw source water in a reverse flow through the filter or filters will not be acceptable.
- The influent, effluent and waste manifolds shall be constructed of schedule 80 PVC piping and fittings. The system shall include (1) three-way hydraulically operated diaphragm valve per tank to direct the flow during the backwash cycle. And one two-way hydraulically operated diaphragm valve as a priority valve.

Semi-Automatic Controls for Diaphragm Valve Face Piping Kits

- Valve actuation to initiate the backwash cycle shall be a single-knob control using a multi-port control valve to distribute water to hydraulically operated multi-port control valve, and influent, effluent, and multi-port pressure gages shall be mounted on a common panel.

Automatic Controls for Diaphragm Valve Face Piping Kits

CS 400 Commercial Backwash Controller

This controller is programmable and controls every aspect of the backwash cycle once initiated. Backwash can be initiated three ways: by an operator with the touch of a button, by a signal from a master controller (such as the AK600), or by a signal from an optional differential pressure switch (CS400-DP). Stored backwash data and history, alarms and calculated backwash cycle times are also features of the CS400 controller, as are relays for communication with the heater, pump and Acu Drive™ XS Variable Frequency Drive.

CA 100 Fully Automatic Backwash Controller

This is the most comprehensive backwash controller and can be readily reprogrammed to initiate backwash automatically based on differential pressure (integral pressure transducers are standard), time (internal seven-day clock with battery back-up is standard), flow (with optional flow sensor), or any combination of the above. The controller has real-time display of operation mode, filter flow rate, and water temperature (with optional temperature probe). Also, includes Energy Saver Mode for simple On/Off pump scheduling and various interlocks and relays to communicate with other equipment (pump, heater, Acu Drive controller).

Certifications

The THS Series filter shall be tested and certified by a nationally recognized testing laboratory to conform to NSF (National Sanitation Foundation) Standard 50.



1620 HAWKINS AVE | SANFORD, NC 27330 | UNITED STATES | 800.831.7133 | pentair.com

All Pentair trademarks and logos are owned by Pentair plc, or one of its global affiliates. THS Series® is a registered trademark of Pentair Water Pool and Spa, Inc. and/or its affiliated companies in the United States and/or other countries. Because we are continuously improving our products and services, Pentair reserves the right to change specifications without prior notice.

Pentair is an equal opportunity employer.

PI-156 10/19 ©2019 Pentair Water Pool and Spa, Inc. All rights reserved.