

INSTALLATION AND OPERATION MANUAL



**Models 1005A - 2005A
Type H, WH, and P**



⚠ WARNING: Improper installation, adjustment, alteration, service or maintenance can cause property damage, personal injury, exposure to hazardous materials* or loss of life. Review the information in this manual carefully. *This unit contains materials that have been identified as carcinogenic, or possibly carcinogenic, to humans.

FOR YOUR SAFETY: Do not store or use gasoline or other flammable vapors and liquids or other combustible materials in the vicinity of this or any other appliance. To do so may result in an explosion or fire.

WHAT TO DO IF YOU SMELL GAS:

- Do not try to light any appliance.
- Do not touch any electrical switch; do not use any phone in your building.
- Immediately call your gas supplier from a neighbor's phone. Follow the gas supplier's instructions.
- If you cannot reach your gas supplier, call the fire department.

Installation and service must be performed by a qualified installer, service agency or the gas supplier.

This manual should be maintained in legible condition and kept adjacent to the heater or in a safe place for future reference.



CATALOG NO. 3400.552E
Effective: 06-10-19
Replaces: 09-20-18
P/N 241513 Rev. 6

CONTENTS

1. WARNINGS	3	4. CONTROLS	39
1.1. Pay Attention to These Terms.....	3	4.1. Ignition Control Functions	39
2. BEFORE INSTALLATION	4	4.2. High Limit - Manual Reset	39
2.1. Product Receipt.....	4	4.3. High Limit - Auto Reset (Optional).....	39
2.2. Model Identification.....	4	4.4. Variable-Speed Injector Pump	39
2.3. Ratings and Certifications.....	4	4.5. Condensate Float Switch	40
2.4. Installations at Elevation.....	4	4.6. Flow Switch	40
2.5. Component Locations.....	5	4.7. Low Water Cut-Off (Optional).....	40
2.6. General Safety.....	6	4.8. High and Low Gas Pressure Switches (Optional).....	40
3. INSTALLATION	7	4.9. Blocked Vent Switch	41
3.1. Installation Codes.....	7	4.10. User Interface	41
3.2. Equipment Base	7	5. WIRING DIAGRAM FOR MODELS	
3.3. Clearances	7	1005A - 2005A	47
3.4. Outdoor Installation	8	6. START-UP	48
3.5. Combustion and Ventilation Air	8	6.1. Pre Start-up.....	48
3.6. Air Supply	11	6.2. Pre Start-up Check.....	48
3.7. Water Piping	12	6.3. Initial Start-up.....	48
3.8. Raypak Integral Cold Water Protection.....	13	6.4. Preparation	48
3.9. Hydronic Heating.....	14	6.5. Start-Up.....	49
3.10. Pool/Spa Water Chemistry	21	7. OPERATION	52
3.11. Gas Supply	21	7.1. Lighting Instructions.....	52
3.12. Electrical Power Connections	23	7.2. To Turn Off Gas To Appliance	52
3.13. Field Wiring Connections.....	24	8. TROUBLESHOOTING	52
3.14. Venting - General	28	8.1. XTherm Error Codes.....	52
3.15. Vent Terminal Location	30	8.2. Heater Errors.....	52
3.16. Venting Installation Tips	31	8.3. Heater Faults.....	52
3.17. Vertical Venting Configurations	31	8.4. XTherm Fault Text.....	53
3.18. Horizontal Through-the-Wall and Direct Vent (Category IV).....	32	9. MAINTENANCE	55
3.19. Direct Vent - Vertical	34	9.1. Suggested Minimum Maintenance Schedule.....	55
3.20. Common Venting	35	9.2. Preventive Maintenance Schedule.....	56
3.21. Outdoor Installation	35	9.3. Filter Maintenance	57
3.22. Condensate Treatment	36	10. APPENDIX	57
3.23. PVC Venting Option (D-32)	37	10.1. Inside Air Contamination.....	57
3.24. Centrotherm™ Polypropylene Venting Option (D-33).....	38	11. IMPORTANT INSTRUCTIONS FOR THE COMMONWEALTH OF MASSACHUSETTS	58

Rev 6 reflects the following changes:

Replaced Raypak logo on the front cover page. Updated the elevation rating on page 4. Removed Table N from page 22. Updated "Wiring Diagram" on page 47. Added a note and a warning to the "Blower Check" on page 49. Updated Figure 55 on page 49. Removed "Manifold Check" section on page 49. Added the "Touchscreen Toolbox Menu" figure on page 50. Removed Table Y from page 50. Added the Raymote Troubleshooting sub-section on page 53. Updated "Semi-Annually" section on page 56. Added a note and updated "As Required" section on page 56. Replaced the "Start-Up Checklist" on page 59. Replaced ISO logo on the back cover page.

1. WARNINGS

1.1. Pay Attention to These Terms

▲ DANGER	Indicates the presence of immediate hazards which will cause severe personal injury, death or substantial property damage if ignored.
▲ WARNING	Indicates the presence of hazards or unsafe practices which could cause severe personal injury, death or substantial property damage if ignored.
▲ CAUTION	Indicates the presence of hazards or unsafe practices which could cause minor personal injury or product or property damage if ignored.
CAUTION	CAUTION used without the warning alert symbol indicates a potentially hazardous condition which could cause minor personal injury or product or property damage if ignored.
NOTE	Indicates special instructions on installation, operation, or maintenance which are important but not related to personal injury hazards.

▲ DANGER: Make sure the gas on which the heater will operate is the same type as that specified on the heater rating plate.

▲ WARNING: Should overheating occur or the gas supply valve fail to shut, do not turn off or disconnect the electrical supply to the heater. Instead, shut off the gas supply at a location external to the heater.

▲ WARNING: Do not use this heater if any part has been under water. Immediately call a qualified service technician to inspect the heater and to replace any part of the control system and any gas control which has been under water.

▲ WARNING: To minimize the possibility of improper operation, serious personal injury, fire, or damage to the heater:

- Always keep the area around the heater free of combustible materials, gasoline, and other flammable liquids and vapors.
- Heater should never be covered or have any blockage to the flow of fresh air to the heater.

▲ WARNING: Risk of electrical shock. More than one disconnect switch may be required to de-energize the equipment before servicing.

▲ WARNING: Both natural gas and propane have an odorant added to aid in detecting a gas leak. Some people may not physically be able to smell or recognize this odorant. If you are unsure or unfamiliar with the smell of natural gas or propane, ask your local gas supplier. Other conditions, such as “odorant fade,” which causes the odorant to diminish in intensity, can also hide, camouflage, or otherwise make detecting a gas leak by smell more difficult.

▲ WARNING: UL-recognized fuel gas detectors are recommended in all enclosed propane and natural gas applications wherein there is a potential for an explosive mixture of fuel gas to accumulate and their installation should be in accordance with the detector manufacturer’s recommendations and/or local laws, rules, regulations, or customs.

▲ CAUTION: If this heater is to be installed in a negative or positive pressure equipment room, there are special installation requirements. Consult factory for details.

▲ CAUTION: If this heater is to be installed above radiation level, it must be provided with a low water cut-off device at the time of heater installation.

2. BEFORE INSTALLATION

Raypak strongly recommends that this manual be reviewed thoroughly before installing your XTherm heater. Please review the General Safety information before installing the heater. Factory warranty does not apply to heaters that have been improperly installed or operated. Refer to the warranty at the back of this manual.

Installation and service must be performed by a qualified installer, service agency or gas supplier. If, after reviewing this manual, you still have questions which this manual does not answer, please contact your local Raypak representative or visit our website at www.raypak.com.

NOTE: Raypak recommends laying out and installing the vent system before installing water piping. This will ensure that the venting system and associated components will fit into the attached space for proper operation.

Thank you for purchasing a Raypak product. We hope you will be satisfied with the high quality and durability of our equipment.

2.1. Product Receipt

On receipt of your heater it is suggested that you visually check for external damage to the shipping crate. If the crate is damaged, make a note to that effect on the Bill of Lading when signing for the shipment. Next, remove the heater from the shipping packaging. Report any damage to the carrier immediately.

On occasion, items are shipped loose. Be sure that you receive the correct number of packages as indicated on the Bill of Lading.

Claims for shortages and damages must be filed with the carrier by consignee. Permission to return goods must be received from the factory prior to shipping. Goods returned to the factory without an authorized Returned Goods Receipt number will not be accepted. All returned goods are subject to a restocking charge.

When ordering parts, you must specify the model and serial number of the heater. When ordering under warranty conditions, you must also specify the date of installation.

Purchased parts are subject to replacement only under the manufacturer's warranty. Debits for defective replacement parts will not be accepted. Parts will be replaced in kind only per Raypak's standard warranties.

2.2. Model Identification

The model identification number and heater serial number are found on the rating plate located on the rear jacket panel of the heater.

The model number will have the form H7 or similar depending on the heater size and configuration.

- The letter(s) in the first group of characters identifies the application (H=Hydronic Heating, WH=Water Heating, P=Pool Heating).

- The number which follows identifies the firing mode (7 = electronic modulation).
- The second group of characters identifies the size of the heater (the four numbers representing the approximate MBTUH input), and, where applicable, a letter, indicating the manufacturing series.

2.3. Ratings and Certifications

2.3.1. Standards

- ANSI Z21.13 · CSA 4.9 - latest edition, Gas-Fired Hot Water Heaters
- CAN 3.1 - latest edition, Industrial and Commercial Gas-Fired Package Heaters
- ANSI Z21.10.3 · CSA 4.3 - latest edition, Gas Water Heaters
- ANSI Z21.56 · CSA 4.7 - latest edition, Gas-Fired Pool Heaters
- SCAQMD Rule 1146.2
- Low-lead content (<.25%) CSA-certified

All Raypak heaters are National Board registered, and design-certified and tested by the Canadian Standards Association (CSA) for the U.S. and Canada. Each heater is constructed in accordance with Section IV of the American Society of Mechanical Engineers (ASME) Heater Pressure Vessel Code and bears the applicable ASME stamp. H models bear the "H" stamp. WH and P models bear the "HLW" stamp. This heater also complies with the latest edition of the ASHRAE 90.1 Standard.

⚠ WARNING: Altering any Raypak pressure vessel by installing replacement heat exchangers, or any ASME parts not manufactured and/or approved by Raypak will instantly void the ASME and CSA ratings of the vessel and any Raypak warranty on the vessel. Altering the ASME or CSA ratings of the vessel also violates national, state, and local approval codes.

2.4. Installations at Elevation

Rated inputs are suitable for up to 4,500 ft. (1,372 m) elevation without de-rating. Consult your local representative or the factory for installations at altitudes over 4,500 ft. (1,372 m) above sea level. No hardware changes are required to the heaters for installations up to 10,000 ft. (3,050 m) (adjustments may be required).

2.5. Component Locations

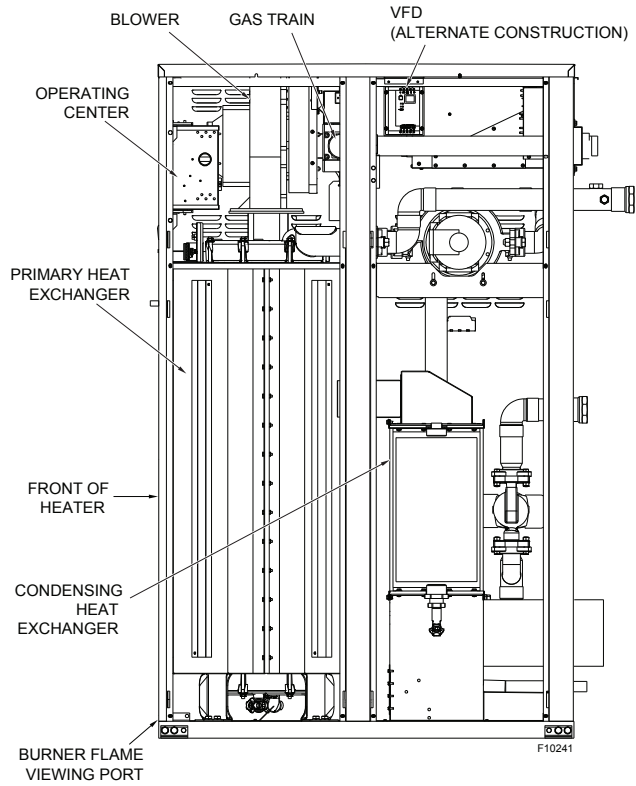

Figure 1. Component Locations – Side View

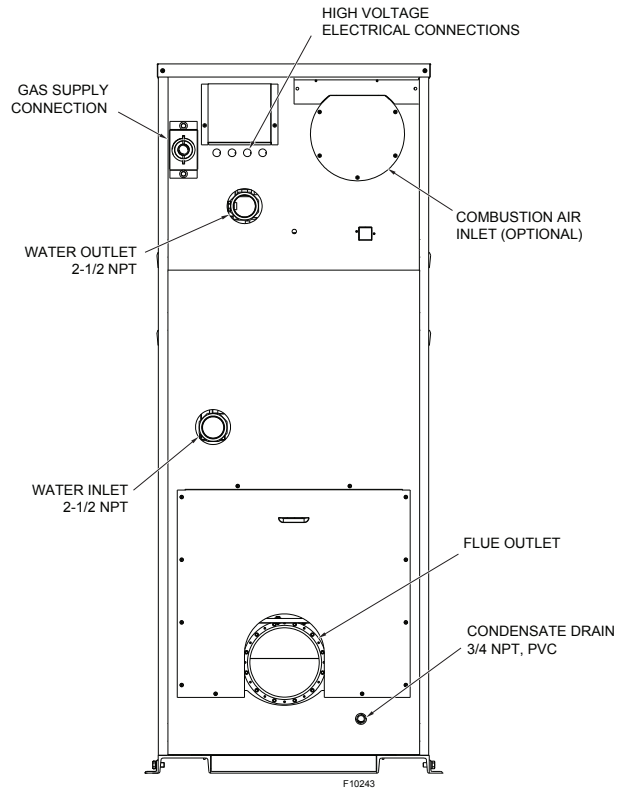

Figure 3. Component Locations - Rear View

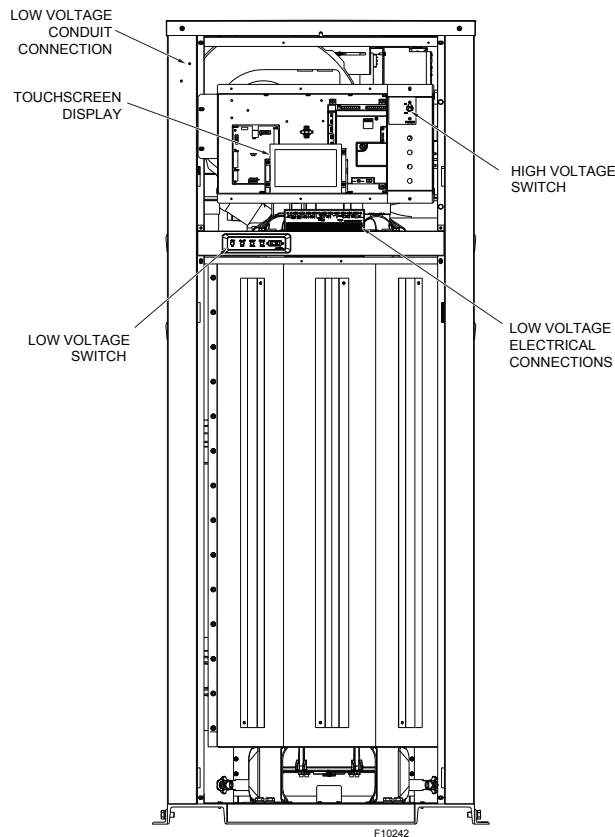

Figure 2. Component Locations - Front View

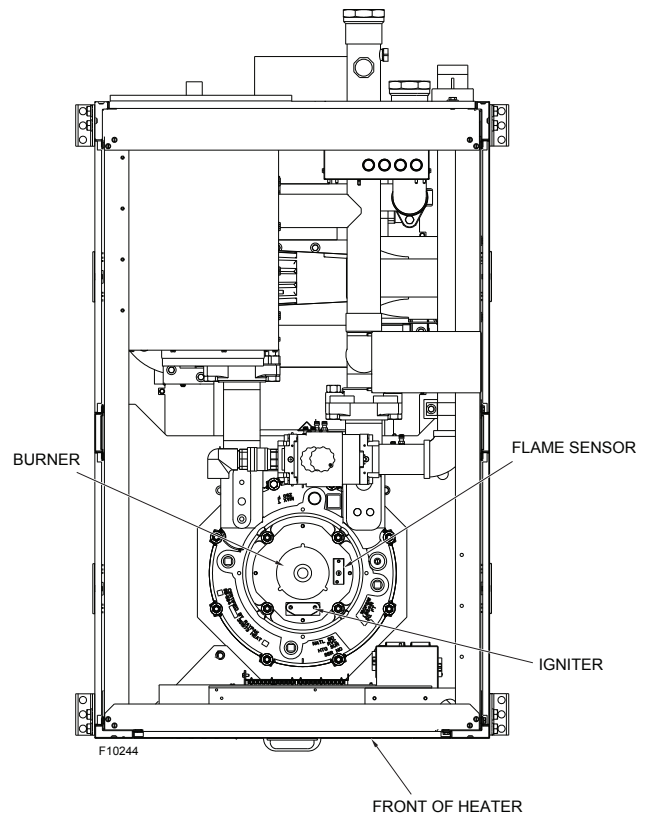

Figure 4. Component Locations - Top View

2.5.1. General Information

Model No.	Input MBTUH (kW)		Water Conn (NPT)	Gas Conn (NPT)		Vent Size In. (mm)	Comb Air In. (mm)
	Max	Min		Nat	LP		
1005A	999 (293)	140 (41.0)	2-1/2"	1-1/4"	1"	6 (152)	6 (152)
1505A	1500 (440)	210 (61.6)	2-1/2"	1-1/4"	1"	8 (203)	8 (203)
2005A	1999 (586)	280 (82.1)	2-1/2"	2"	1"	8 (203)	8 (203)

Table A. Basic Product Data

2.6. General Safety

This section applies to Hot Water Supply Boilers and Hot Water Heaters ONLY.

To meet commercial hot water use needs, the high limit safety control on this water heater will shut off the main gas valve before the outlet temperature reaches 210°F (99°C). However, water temperatures over 125°F (52°C) can cause instant severe burns or death from scalds. When supplying general purpose hot water, the recommended initial setting for the temperature control is 125°F (52°C).

For sanitary rinse applications where outlet temperatures of 180°F (82°C) to 195°F (91°C) are required, a boiler is required because the 210°F (99°C) limit on water heaters will NOT allow the heater to maintain these desired sanitary rinse temperatures.

Safety and energy conservation are factors to be considered when setting the water temperature on the thermostat. The most energy-efficient operation will result when the temperature setting is the lowest that satisfies the needs of the application.

Water temperature over 125°F (52°C) can cause instant severe burns or death from scalds. Children, disabled and elderly are at highest risk of being scalded. See **Table B**.

- Feel water before bathing or showering.
- Temperature limiting valves are available.

NOTE: When this water heater is supplying general-purpose hot water for use by individuals, a thermostatically-controlled mixing valve for reducing point-of-use water temperature is recommended to reduce the risk of scald injury. Contact a licensed plumber or the local plumbing authority for further information.

Maximum water temperatures occur just after the heater's burner has shut off. To determine the water temperature being delivered, turn on a hot water faucet and place a thermometer in the hot water stream and read the thermometer.

CAUTION: Hotter water increases the risk of scalding! There is a hot water scald potential if the thermostat is set too high.

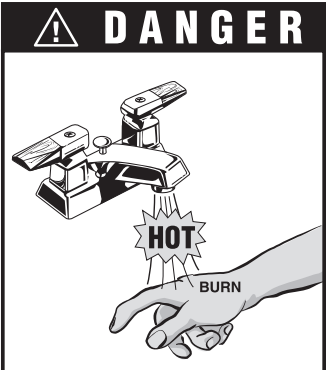

Water temperature over 125°F can cause instant severe burns or death from scalds.

Children, disabled, and elderly are at highest risk of being scalded.

See instruction manual before setting temperature at water heater.

Feel water before bathing or showering.

Temperature limiting valves are available, see manual.

Water Temp.	Time To Produce Serious Burn
120°F (49°C)	More than 5 minutes
125°F (52°C)	1-1/2 to 2 minutes
130°F (54°C)	About 30 seconds
135°F (57°C)	About 10 seconds
140°F (60°C)	Less than 5 seconds
145°F (63°C)	Less than 3 seconds
150°F (66°C)	About 1-1/2 seconds
155°F (68°C)	About 1 seconds

Table B. Time to Produce Serious Burn

3. INSTALLATION

3.1. Installation Codes

Installations must follow these codes:

- Local, state, provincial, and national codes, laws, regulations and ordinances
- National Fuel Gas Code, ANSI Z223.1/NFPA 54 – latest edition (NFGC)
- National Electrical Code, ANSI/NFPA 70 - latest edition (NEC)
- Standard for Controls and Safety Devices for Automatically Fired Heaters, ANSI/ASME CSD-1, (CSD-1) when required
- For Canada only: CAN/CSA B149 Natural Gas and Propane Installation Code and CSA C22.1 C.E.C. Part 1 (C22.1)

CAUTION: This heater should be located in an area where water leakage will not result in damage to the area adjacent to the appliances or to the structure. When such locations cannot be avoided, it is recommended that a suitable catch pan, adequately drained, be installed under the appliance. The pan must not restrict air flow.

In addition, the heater shall be installed such that the gas ignition system components are protected from water (dripping, spraying, rain, etc.) during appliance operation or service (circulator replacement, control replacement, etc.).

If the heater needs to be secured to the ground, use the hole pattern shown in **Figure 5**, following local codes. Additional clearance may be required when using the factory anchor bracket.

3.3. Clearances

3.3.1. Indoor Installations

Heater Side	Minimum Clearances from Combustible Surfaces in. (mm)	Minimum Service Clearance in. (mm)
Floor *	0	0
Rear	12 (305)	36 (914)
Right Side	1 (25)	24 (610)
Left Side	1 (25)	1 (25)
Top	0	10 (254)
Front	Open	24 (610)
Vent	1 (25)	1 (25)

See also National Fuel Gas Code, Table 10.2.3, *Clearance Reduction*

* DO NOT install on carpeting

Table C. Clearances - Indoor Installations

For ease of servicing, a clearance of at least 24" (610 mm) on the right side, at least 24" (610 mm) in front and 36" (914 mm) above the top of the heater is required. This will allow the heater to be serviced in its installed location without movement or removal of the heater.

Service clearances less than the minimum may require removal of the heater to service either the heat exchanger or the burner components. In either case, the heater must be installed in a manner that will enable the heater to be serviced without removing any structure around the heater.

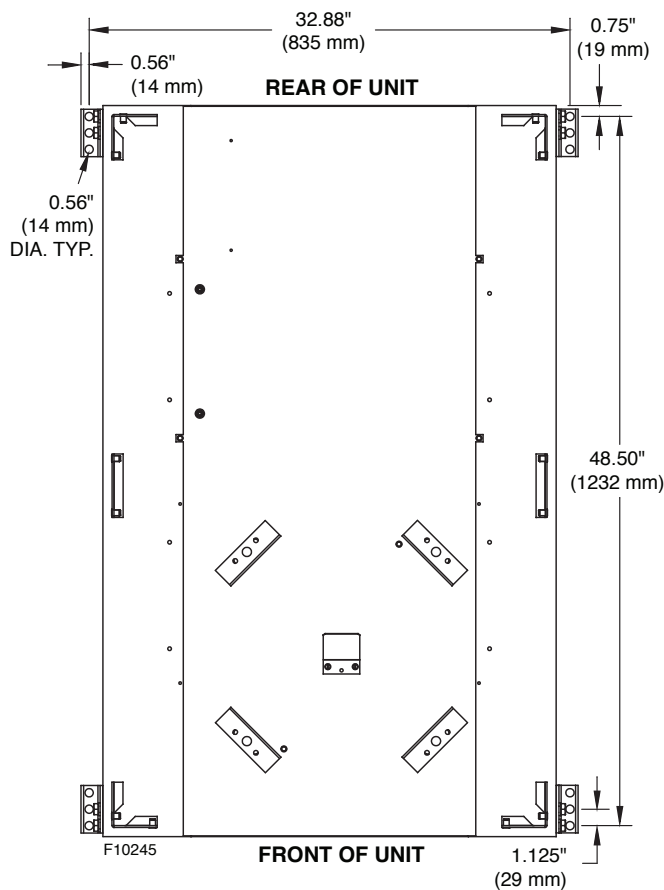
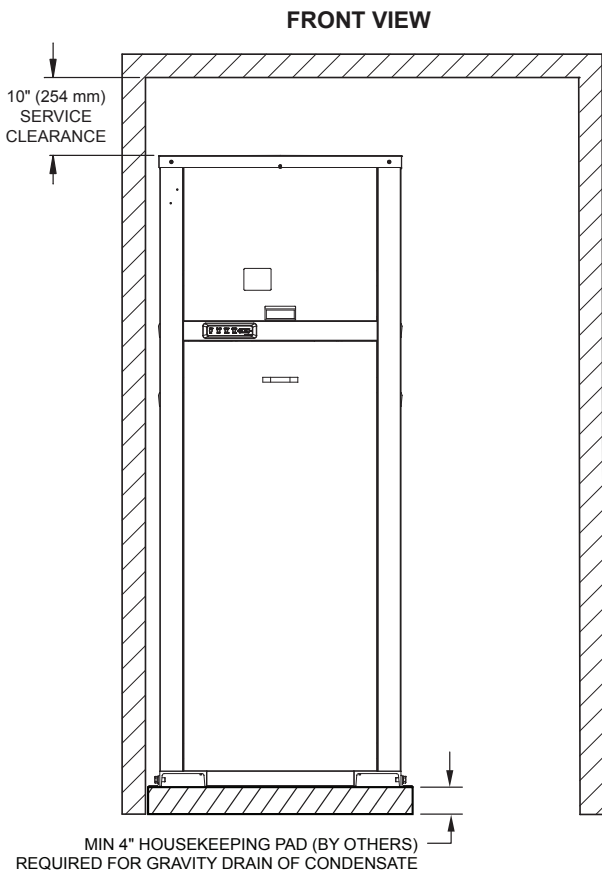
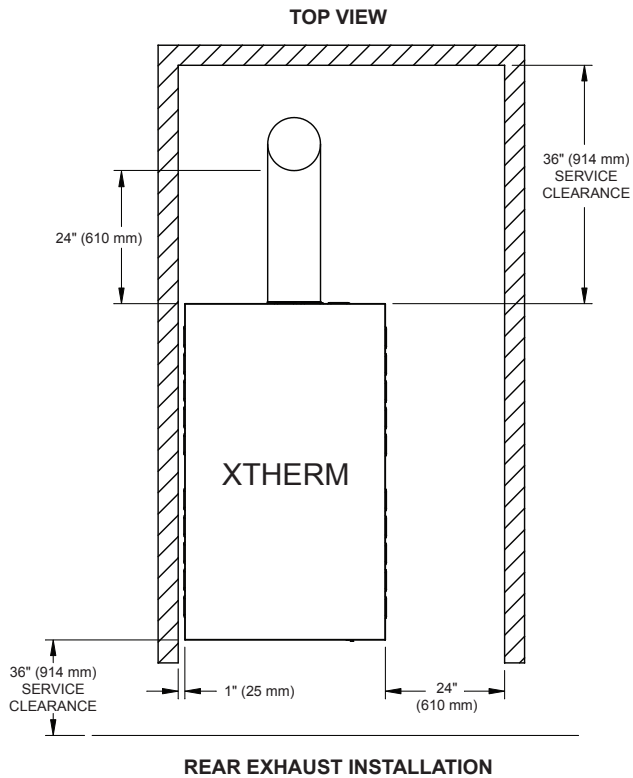

Figure 5. XTherm 1005A-2005A Anchor Hole Locations

3.2. Equipment Base

The heater should be mounted on a level, structurally sound housekeeping pad. The heater is approved for installation on a combustible surface but must NEVER be installed on carpeting. Gas-fueled equipment installed in enclosed parking garages must be located at least 18" (457 mm) above the floor.



3.4. Outdoor Installation

Heaters must not be installed under an overhang unless clearances are in accordance with local installation codes and the requirements of the gas supplier.

Three sides must be completely open in the area under the overhang. Roof water drainage must be diverted away from heaters installed under overhangs.

⚠ CAUTION: Do not install where the condensate can freeze. Take appropriate measures.

Heater Side	Minimum Clearances from Combustible Surfaces in. (mm)	Minimum Service Clearance in. (mm)
Rear	12 (305)	36 (914)
Right Side	1 (25)	24 (610)
Left Side	1 (25)	1 (25)
Top	Unobstructed	Unobstructed
Vent Termination	12 (305)	12 (305)

Table D. Clearances – Outdoor Installations

3.5. Combustion and Ventilation Air

NOTE: Use of this heater in construction areas where fine particulate matter, such as concrete or dry-wall dust, is present may result in damage to the heater that is not covered by the warranty. If operated in a construction environment, a clean source of combustion air must be provided directly to the heater.

3.5.1. Indoor Units

NOTE: On Indoor installations, the clear panel in the outer bezel may be removed to allow access to the touchscreen without removing the outer panel.

This heater must be supplied with sufficient quantities of non-contaminated air to support proper combustion and equipment ventilation. Combustion air can be supplied via conventional means where combustion air is drawn from the area immediately surrounding the heater, (as shipped from factory, combustion air is drawn through louvers in jacket panels) or via direct vent, where combustion air is drawn directly from outside. (See **Section 3.6.1** for instructions on how to connect ducting to the unit). All installations must comply with the requirements of the NFGC (U.S.) and B149 (Canada), and all local codes.

⚠ CAUTION: Combustion air must not be contaminated by corrosive chemical fumes which can damage the heater and cause a non-warrantable failure. See the Appendix.

NOTE: It is recommended that the intake vent be insulated to minimize sweating in freezing climates.

Figure 6. Minimum Clearances from Combustible Surfaces – Indoor and Outdoor Installations

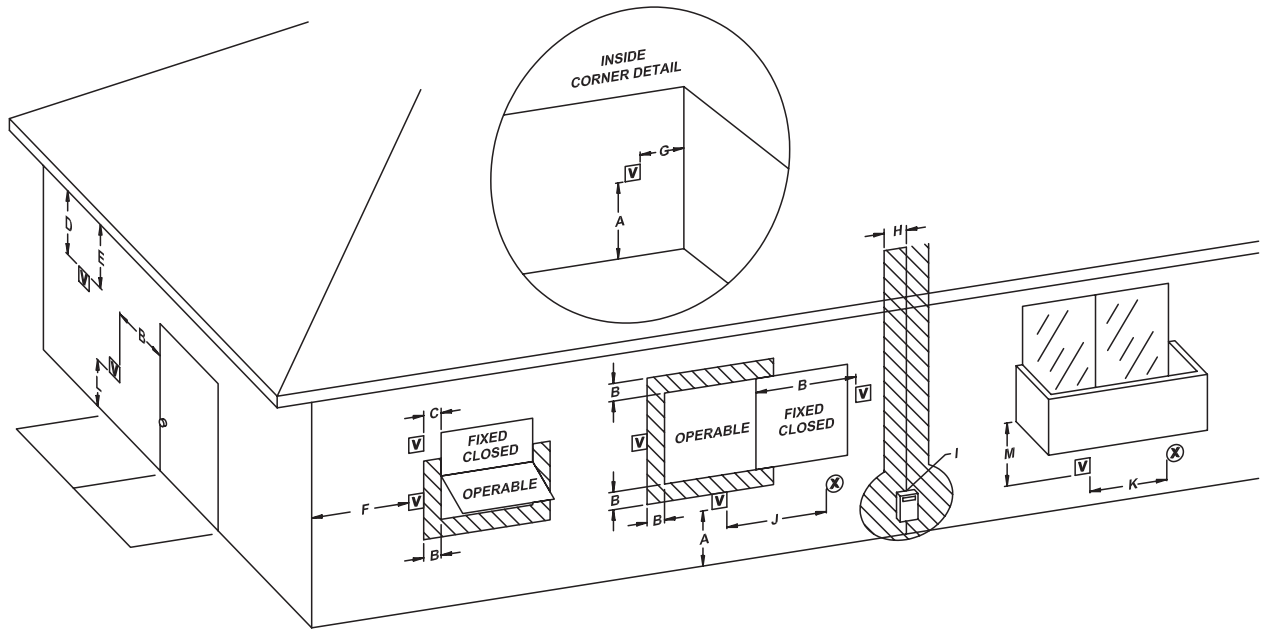

Figure 7. Minimum Clearances from Vent/Air Inlet Terminations – Indoor and Outdoor Installations

		U.S. Installations ¹	Canadian Installations ²
A	Clearance above grade, veranda, porch, deck, or balcony	1' (30 cm)	1' (30 cm)
B	Clearance to window or door that may be opened	4' (1.2 m) below or to side of opening	3' (91 cm)
C	Clearance to permanently closed window	*	*
D	Vertical clearance to ventilated soffit located above the terminal within a horizontal distance of 2' (61 cm) from the centerline of the terminal	5' (1.5 m)	*
E	Clearance to unventilated soffit	*	*
F	Clearance to outside corner	*	*
G	Clearance to inside corner	6' (1.83 m)	*
H	Clearance to each side of center line extended above meter/regulator assembly	*	3' (91 cm) within a height 15' above the meter/regulator assembly
I	Clearance to service regulator vent outlet	*	6' (1.83 m)
J	Clearance to non-mechanical air supply inlet to building or the combustion air inlet to any other appliance	4' (1.2 m) below or to side of opening; 1' (30 cm) above opening	3' (91 cm)
K	Clearance to mechanical air supply inlet	3' (91 cm) above if within 10' (3 m) horizontally	6' (1.83 m)
L	Do not terminate above paved sidewalk or paved driveway	Slip hazard due to frozen condensate	Slip hazard due to frozen condensate
M	Clearance under veranda, porch, deck or balcony	*	12" (30 cm) ^t

¹ In accordance with the current ANSI Z223.1/NFPA 54 National Fuel Gas Code.

² In accordance with the current CAN/CSA-B149 Installation Codes.

^t Permitted only if veranda, porch, deck, or balcony is fully open on a minimum of two sides beneath the floor and top of terminal, and underside of veranda, porch, deck or balcony is greater than 1' (30 cm).

* Clearances in accordance with local installation codes and the requirements of the gas supplier.

Table E. Vent/Air Inlet Termination Clearances

3.5.2. Combustion Air Filter

This heater is supplied with an integral combustion air filter. This filter will reduce the amount of particulates passed through the combustion system and heat exchanger but will not protect against chemical air contamination (See Appendix). The filter must be checked periodically to verify that adequate combustion air is being supplied to the heater. See the Maintenance section of this manual for information on checking the filter and establishing service intervals.

3.5.3. Ducted Combustion Air

Combustion air may be ducted directly to the heater using PVC, CPVC or sealed single-wall galvanized ducting. The resulting installation meets the requirements for a direct-vent installation. See venting section for detailed information.

1. Install combustion air duct in accordance with **Figure 38** and **Figure 39**.
2. Ventilation of the space occupied by the heater(s) is required and can be provided by an opening(s) for ventilation air at the highest practical point communicating with the outdoors. The total cross-sectional areas must be at least 1 in.² of free area per 20,000 BTUH (111 mm² per kW) of total input rating of all equipment in the room, when the opening is communicating directly with the outdoors or through vertical duct(s). The total cross-sectional area must be at least 1 in.² of free area per 10,000 BTUH (222 mm² per kW) of total input rating of all equipment in the room, when the opening is communicating with the outdoors through horizontal duct(s). Damage to the equipment due to inadequate ventilation of the space is not a warrantable failure.
3. In cold climates, and to mitigate potential freeze-up, Raypak highly recommends the installation of a motorized sealed damper to prevent the circulation of cold air through the heater during the non-operating hours. Such a damper must be electrically interlocked to the unit(s) such that a call for heat from any connected unit will energize the damper, but no connected unit is allowed to fire until the damper proves fully open.

3.5.4. Installation Instructions

1. Turn off all power to the heater. All necessary parts are provided with the appliance.
2. Ensure that the heater is cool to the touch before proceeding with the installation.
3. Remove both the left and right rear side access panels.
4. From the right-rear side access area, install the inside air intake cover panel using the nine hex-head screws provided. See **Figure 8**.

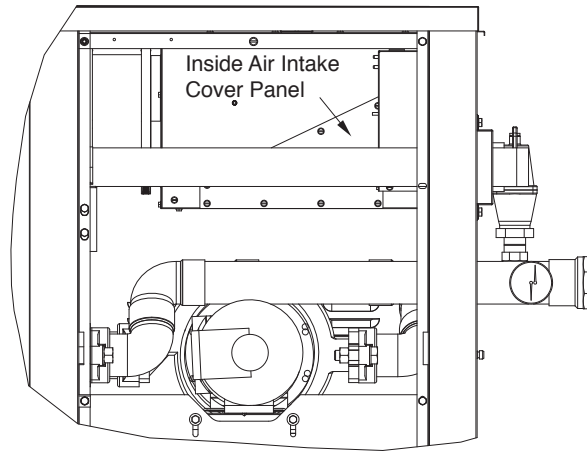

Figure 8. Install the Inside Air Intake Cover Panel

5. Optional—For applications where condensation may form on cold intake air ducting, install the condensate drip pan to the bottom of the air filter box using the four screws provided (verify that the pan is angled slightly downward toward the rear of the heater as shown in **Figure 9**).

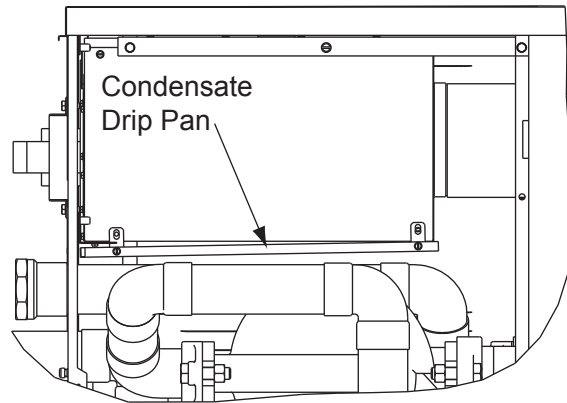

Figure 9. Install the Condensate Drip Pan

6. Remove the air intake cover panel by removing the five Phillips head screws holding it in place.

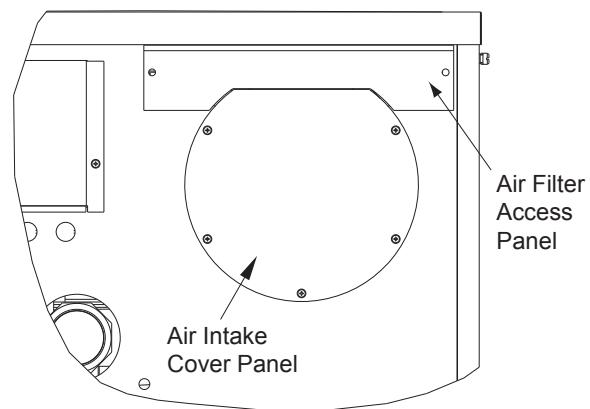

Figure 10. Remove the Air Intake Cover

- Remove the debris screen (or cover panel for model 1005A) by removing the screws holding it in place.

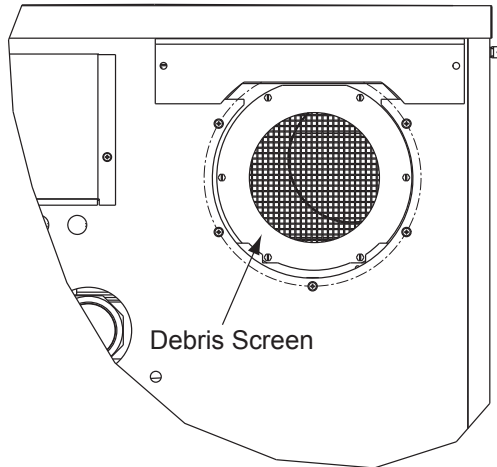

Figure 11. Remove the Debris Screen

- Install the intake air collar using the six screws removed in Step 7.

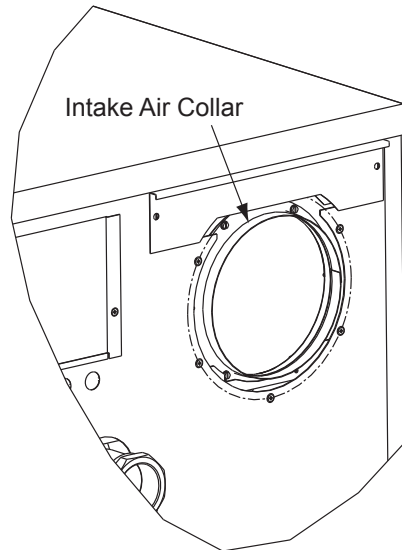

Figure 12. Install the Intake Air Collar

- Replace all the access panels.
- 1 Install ducted air intake piping appropriate for your installation using PVC, CPVC or sealed single-wall galvanized ducting. The duct will attach directly to the field-installed air collar located on the rear of the heater, using three or four sheet metal screws (not supplied) equally positioned around the circumference of the duct.

NOTE: Make sure that the air intake piping is installed in a manner that allows full access to the air filter without damage to the filter.

3.5.5. TruSeal® Combustion Air

In addition to the previous steps, the combustion air system can be sealed to meet Direct Vent requirements by sealing the mounting screws and duct connection point with RTV (not supplied). All ducting **MUST** be self-supported.

▲ CAUTION: Use TruSeal combustion air if damaging airborne contaminants are or may be present in the heater area. See the Appendix of this manual regarding air contamination.

3.6. Air Supply

3.6.1. U.S. Installations

All Air from Inside the Building

The confined space shall be provided with TWO permanent openings communicating directly with an additional room(s) of sufficient volume so that the combined volume of all spaces meets the criteria for a room large in comparison (NFGC). The total input of all gas utilization equipment installed in the combined space shall be considered in making this determination.

Each opening shall have a minimum free area of 1 square inch per 1,000 BTUH (2,225 mm² per kW) of the total input rating of all gas utilization equipment in the confined space, but not less than 100 square inches (645 cm²). One opening shall commence within 12" (305 mm) of the top, and one opening shall commence within 12" (305 mm) of the bottom of the enclosure. The minimum dimension of air openings shall be not less than 3" (76 mm) in any direction.

All Air from Outdoors

The confined space shall communicate with the outdoors in accordance with one of the methods below. The minimum dimension of air openings shall not be less than 3" (76 mm) in any direction. Where ducts are used, they shall be of the same cross-sectional area as the net free area of the openings to which they connect.

- Two permanent openings**, one commencing within 12" (305 mm) of the top, and one commencing within 12" (305 mm) of the bottom of the enclosure, shall be provided. The openings shall communicate directly, or by ducts, with the outdoors or spaces (crawl or attic) that freely communicate with the outdoors.
 - Where directly communicating with the outdoors or where communicating to the outdoors through vertical ducts, **each opening** shall have a minimum free area of 1 square inch per 4,000 BTUH (550 mm² per kW) of total input rating of all equipment in the enclosure.

- b. Where communicating with the outdoors through horizontal ducts, **each opening** shall have a minimum free area of 1 square inch per 2,000 BTUH (1,100 mm² per kW) of total input rating of all equipment in the enclosure.

2. **One permanent opening**, commencing within 12" (305 mm) of the top of the enclosure, shall be permitted where the equipment has clearances of at least 1" (25.4 mm) from the sides and back and 6" (152 mm) from the front of the appliance. The opening shall directly communicate with the outdoors or shall communicate through a vertical or horizontal duct to the outdoors or spaces that freely communicate with the outdoors, and shall have a minimum free area of:

- a. 1 square inch per 3,000 BTUH (740 mm² per kW) of the total input rating of all equipment located in the enclosure, and
- b. Not less than the sum of the areas of all vent connectors in the confined space.

⚠ WARNING: Do not use the "one permanent opening" method if the equipment room is under negative-pressure conditions.

3.6.2. Canadian Installations

⚠ CAUTION: All combustion air must be drawn from the air outside of the building; the mechanical equipment room must communicate directly with the outdoors.

Ventilation of the space occupied by the heater shall be provided by an opening(s) for ventilation air at the highest practical point communicating with the outdoors. The total cross-sectional area of such an opening(s) shall be at least 10% of the area required below, but in no case shall the cross-sectional area be less than 10 square inches (65 cm²).

⚠ WARNING: Make sure that the equipment room is not under negative-pressure conditions.

1. Ventilation of the space occupied by the heater shall be provided by an opening(s) for ventilation air at the highest practical point communicating with the outdoors. The total cross-sectional area of such an opening(s) shall be at least 10% of the area required in steps 2 and 3 (below), but in no case shall the cross-sectional area be less than 10 in.² (65 cm²).
2. For heaters using a barometric damper in the vent system there shall be a permanent air supply opening(s) having a cross section area of not less than 1 in.² per 7,000 BTUH (320 mm² per kW) up to and including 1 million BTUH, plus 1 in.² per 14,000 BTUH (160 mm² per kW) in excess of 1 million BTUH. This opening(s) shall be either located at or ducted to a point not more than 18" (450 mm) nor less than 6" (152 mm) above the floor level. The duct can also

"goose neck" through the roof. The duct is preferred to be straight down and terminated 18" (450 mm) from the floor, but not near piping. This air supply opening requirement shall be in addition to the air opening for ventilation air required in 1 (above).

⚠ WARNING: Care must be taken to ensure that the equipment room is not under negative pressure conditions.

3. For heaters not using a barometric damper in the vent system, and when air supply is provided by natural air flow from outdoors for a power burner and there is no draft regulator, drafthood or similar flue gas dilution device installed in the same space, in addition to the opening for ventilation air required above, there shall be a permanent air supply opening(s) having a total cross-sectional area of not less than 1 square inch for each 30,000 BTUH (74 mm² per kW) of total rated input of the burner(s), and the location of the opening(s) shall not interfere with the intended purpose of the opening(s) for ventilation air referred above. This opening(s) can be ducted to a point not more than 18" (450 mm) nor less than 6" (152 mm) above the floor level. The duct can also "goose neck" through the roof. The duct is preferred to be straight down 18" (450 mm) from the floor, but not near piping.
4. Refer to the B149 Installation Code for additional information.

3.7. Water Piping

3.7.1. General

The heater should be located so that any water leaks will not cause damage to the adjacent area or structures.

⚠ CAUTION: This heater must be installed with a Primary-Secondary piping arrangement for the integral pumping system to function properly.

NOTE: Minimum pipe size for the heater inlet/outlet connections is dependent on the equivalent length of piping between the load loop and the heater loop, the operating conditions and the size of the heater. See Table G and Table H.

3.7.2. Relief Valve Piping

⚠ WARNING: Pressure relief valve discharge piping must be piped near the floor and close to a drain to eliminate the potential of severe burns. Do not pipe to any area where freezing could occur. Refer to local codes.

3.7.3. Temperature & Pressure Gauge

The temperature and pressure gauge is shipped threaded onto the heater outlet assembly.

3.7.4. Hydrostatic Test

Unlike many types of heaters, this heater does not require hydrostatic testing prior to being placed in operation. The heat exchanger has already been factory-tested and is rated for 160 psi (1100 kPa) operating pressure. However, Raypak does recommend hydrostatic testing of the piping connections to the heater and the rest of the system prior to operation. This is particularly true for hydronic systems using expensive glycol-based anti-freeze. Raypak recommends conducting the hydrostatic test before connecting gas piping or electrical supply. Leaks must be repaired at once to prevent damage to the heater. NEVER use petroleum-based stop-leak compounds. Isolate heater water connections from the system prior to performing a hydrostatic test.

To perform hydrostatic test:

1. Connect fill water supply. Fill heater with water. Carefully fill the rest of the system, making sure to eliminate any entrapped air by using high-point vents. Close feed valve. Test at standard operating pressure for at least 24 hours.
2. Make sure constant gauge pressure has been maintained throughout test.
3. Check for leaks. Repair any that are found.

3.7.5. System Sensor Installation

The System Sensor (S3) is required for all piping configurations unless the units firing rate will be controlled by an external source such as our Temp Tracker MOD+ Hybrid sequencer. Proper placement and method of installation are critical for proper operation of the system. The sensor must be installed in a drywell in conjunction with heat conductive compound as shown in **Figure 13**. The drywell must be installed no more than 5 equivalent feet (1.52 m) of pipe/tubing downstream of the de-coupler and installed in such a way that ensures the sensor bulb is in the flow path.

⚠ CAUTION: Be careful when installing the drywell not to over-tighten the well as this can damage the well and may prevent the sensor from fitting properly.

Locating the sensor on the outside of the pipe will slow the unit's response and yield less accurate results. Use 18AWG wire minimum for sensor wiring.

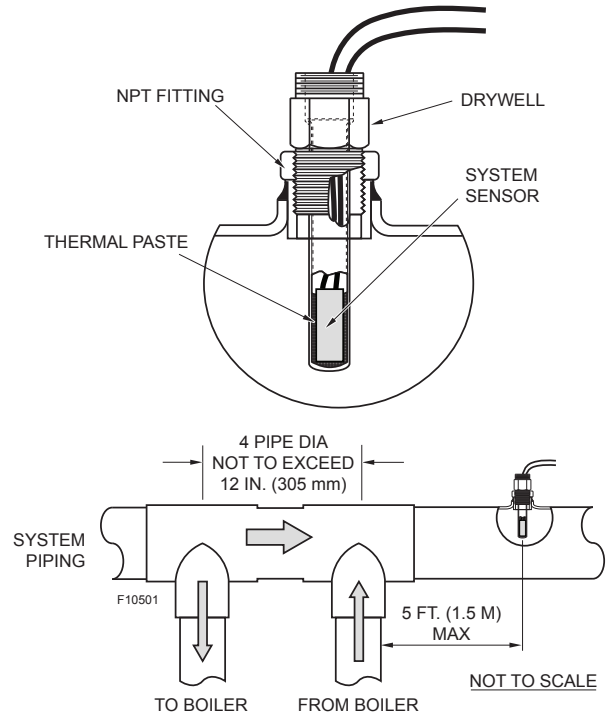

Figure 13. System Sensor Installation

3.8. Raypak Integral Cold Water Protection

XTherm heaters are equipped with an integral CWP system that utilizes a Variable-Speed Pump or pumps to inject just the right amount of water from the main system loop into the heater loop to maintain the optimum inlet temperature. This feature allows the system to achieve and maintain a specific inlet temperature target.

XTherm H boiler models equipped with the dual-injector pump system are designed to operate with heater inlet water temperatures down to 50°F (10°C) continuous. Under start-up conditions the dual-injector system can operate with fluid temperatures down to 32°F (0°C). Continuous operation below 50°F (10°C) return water temperature may cause operational issues for the unit as well as temperature control instability. XTherm WH models equipped with the single-injector pump system are constructed with materials appropriate for domestic hot water operating conditions. XTherm P models are equipped with a single-injector pump system and are constructed with all nonferrous materials for rust-free operation. Contact your local representative or the factory for applications assistance.

For detailed information about CWP in VERSA-equipped systems, see VERSA IC manual (5000.72).

⚠ CAUTION: Damage due to internal condensation may occur if the primary heat exchanger inlet temperature does not exceed 120°F (49°C) within 7 minutes of startup. Warranty claims will be denied for damage or failures caused by condensation.

3.9. Hydronic Heating

3.9.1. Pump Selection

The heater is equipped with an integral cold water protection system that includes either Single or dual modulating injector pumps to pull the required flow from the system loop and a heater pump for the optimal ΔT across the primary heat exchanger. The system is designed for continuous return temperatures from 50°F to 200°F (10°C to 93°C).

NOTE: Higher return temperatures may limit the firing rate when the maximum water temperature of 240°F (115°C) is approached.

NOTE: All hot water heating systems have unique levels of operating diversity that must be accounted for in the system design. The system should always include adequate system flow in excess of the connected heater flow for proper operation of the primary/secondary system. Where the system flow may drop below the connected heater flow a buffer/decoupler may be needed. Failure to design for adequate flow (i.e. bypasses, 3-way control valves, flow-limiting balance devices, buffer tanks, etc.) will result in heater short-cycling and may reduce heater life. Always contact your local Raypak representative for system design assistance to avoid these issues.

3.9.2. Feedwater Regulator

Raypak recommends that a feedwater regulator be installed and set at 12 psi (8.3 kPa) minimum pressure at the highest point of the system. Install a check valve or back flow device upstream of the regulator, with a manual shut-off valve as required by local codes.

3.9.3. Piping

All high points should be vented. A heater installed above radiation level must be provided with a low water cut-off device (sales order option F-10). This heater, when used in connection with a refrigeration system, must be installed so that the chilled medium is piped in parallel with the heater with appropriate valves to prevent the chilled medium from entering the heater. System flow must exceed 115% of max heater flow.

The piping system of a hot water heater connected to heating coils located in air-handling units where they may be exposed to circulating refrigerated air, must be equipped with flow-control valves or other automatic means to prevent gravity circulation of the heater water during the cooling cycle. It is highly recommended that the piping be insulated.

XTherm heaters require access to a certain amount of water to provide adequate thermal mass for stable operation. If the volume of water in the heater loop is not adequate, the outlet temperature may rise faster than the onboard controls can react, causing a high limit fault. In such a case, a buffer tank in the system loop (across the heater connections) is required to provide the difference

between the needed volume and the available loop volume. See **Table F**.

Model Size	Internal Water Volume (gal. / liters)	Minimum Loop Volume Needed (gal. / liters)
1005A	11.8 (45)	21 (79)
1505A	12.4 (48)	31 (117)
2005A	15.6 (59)	41 (155)

Table F. Minimum Hydronic Loop Volume

3.9.4. Air-Separation/Expansion Tank

All heaters should be equipped with a properly-sized expansion tank and air separator fitting as shown in **Figure 15**.

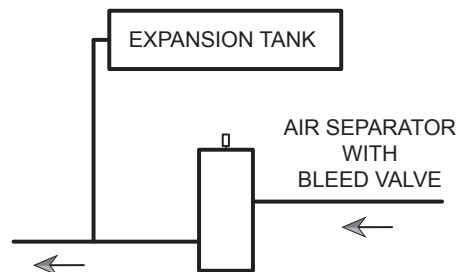

Figure 15. Air-Separation/Expansion Tank

Fitting Type	Equivalent Length (ft/m)	
	2-1/2" NPT	3" NPT
90° Elbow (Std.)	8.5 (2.5)	9.4 (2.8)
90° Elbow (Long rad.)	3.5 (1)	3.6 (1.1)
45° Elbow	3.0 (0.9)	3.4 (1)
Gate Valve (Full open)	1.6 (0.5)	1.6 (0.5)
Swing Check Valve	22 (6.7)	25 (7.6)

Table G. Equivalent Lengths of Pipe for Typical Screw Fittings

3.9.5. Three-Way Valves

Three-way valves intended to regulate system water temperatures by reducing flow in the heater must not be used. Raypak heaters are high-recovery, low-mass heaters which are not subject to thermal shock.

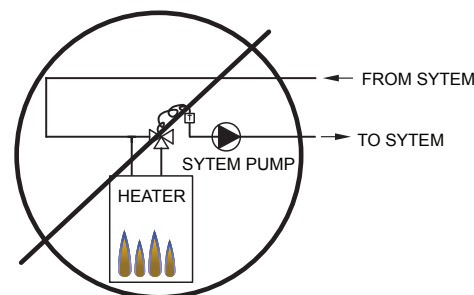

Figure 14. Three-Way Valves (Usage as shown NOT supported)

Tank/ Return Temp (°F / °C)	Model 1005A			Model 1505A			Model 2005A		
	Supply Temp ¹ (°F / °C)	Min. Tubing Size ²		Supply Temp ¹ (°F / °C)	Min. Tubing Size ²		Supply Temp ¹ (°F / °C)	Min. Tubing Size ²	
		<80' equiv.	80-200' equiv.		<80' equiv.	80-200' equiv.		<80' equiv.	80-200' equiv.
60 (15)	147 (64)	2" NPT	2-1/2" NPT	147 (64)	2" NPT	2-1/2" NPT	154 (68)	2" NPT	2-1/2" NPT
80 (27)	147 (64)	2" NPT	2-1/2" NPT	147 (64)	2" NPT	2-1/2" NPT	154 (68)	2-1/2" NPT	3" NPT
100 (38)	147 (64)	2-1/2" NPT	3" NPT	147 (64)	2-1/2" NPT	3" NPT	154 (68)	2-1/2" NPT	3" NPT
120 (49)	145 (63)	2-1/2" NPT	3" NPT	158 (70)	2-1/2" NPT	3" NPT	170 (77)	2-1/2" NPT	3" NPT
140 (60)	165 (74)	2-1/2" NPT	3" NPT	178 (81)	2-1/2" NPT	3" NPT	190 (88)	2-1/2" NPT	3" NPT
160 (71)	185 (85)	2-1/2" NPT	3" NPT	198 (92)	2-1/2" NPT	3" NPT	210 (99)	2-1/2" NPT	3" NPT

¹ Approximate high fire heater outlet temperature based on the standard heater pump and the recommended connecting pipe size.

² Minimum pipe size based on total equivalent feet of supply and return piping between the system loop and heater, not to exceed 2.7 ft of head at 70 gpm.

Table H. Boiler Temperatures and Minimum Pipe Size at Varying Return Temperatures

Model	System Return Temperature												
	50°F (°C)		70°F (°C)		90°F (°C)		110°F (°C)		120°F (°C)				
	Low Fire (gpm/lpm)	High Fire (gpm/lpm)	Low Fire (gpm/lpm)	High Fire (gpm/lpm)	Low Fire (gpm/lpm)	High Fire (gpm/lpm)	Low Fire (gpm/lpm)	High Fire (gpm/lpm)	Low Fire (gpm/lpm)	High Fire (gpm/lpm)			
1005A	4 (15)	21 (79)	5 (19)	27 (102)	8 (32)	38 (144)	20 (76)	61 (231)		70 (265)*	87 (329)**	70 (265)*	87 (329)**
1505A	6 (23)	31 (117)	8 (30)	39 (148)	12 (45)	53 (201)	29 (110)	70 (265)*	82 (310)**	70 (265)*	113 (428)**	70 (265)*	113 (428)**
2005A	7 (27)	38 (143)	10 (38)	48 (182)	16 (61)	63 (238)	37 (140)	70 (265)*	91 (344)**	70 (265)*	116 (439)**	70 (265)*	116 (439)**

* Flow rates are shown for standard models. Pipe size selection not to exceed 2.7 ft hd pressure drop at 70 gpm (265 lpm)

** For High Temp/Process unit utilizing a single injector pump, pipe sizing to be based on the following:

H7-1005A - 87 gpm @ 3.5 ft (329 lpm @ 1 m) hd pressure drop
H7-1505A - 113 gpm @ 7.6 ft (428 lpm @ 2.3 m) hd pressure drop
H7-2005A - 116 gpm @ 8 ft (439 lpm @ 2.4 m) hd pressure drop

NOTE: System flow must be greater than boiler flow at all time for proper operation.

Table I. Injection Flow Rates vs Return Water Temperatures

3.9.6. Applications and Modes - Primary/ Secondary Piping

The VERSA IC Control system is designed for a wide range of applications. The installer/design engineer should refer to the following Modes to determine which best fits the intended application and functionality for the unit being installed. Type H models of XTherm have three modes available to them to address the various applications the units can be applied to. Type WH units will only have the WH configuration available to them for use with potable water applications when directly connected to a hot water storage tank. Type P units will only have the P configuration available. For detailed information on the VERSA IC control system, see the VERSA IC manual (5000.72). This manual can be found in the document library at www.raypak.com.

Mode 1 (Type H Units Only)

This mode selection is for hydronic heating systems with single or multiple heaters (Maximum 4 heaters) in primary/secondary piping configuration with or without Outdoor Air Reset (S4). See **Figure 16** and **Figure 17**.

Sensor	Name	Installed at		Applies to Mode
		Factory	Field	
S1	Inlet	X		All
S2	Outlet	X		All
S3	System		X	All
S4	Outdoor Air		X	H w/ Outdoor Reset
S5	Indirect DHW		X	H mode 2
			X	H mode 3
S6	Indirect Supply		X	H mode 3
	Poolstat		X	P

Table J. Sensor Usage

The system temperature is controlled by the System sensor (S3). The integral boiler pump (P1) runs during any call for heat. The System Pump (P2) runs whenever the system is enabled for heating and the outdoor air temperature is lower than the WWSD temperature setting (if utilized).

The System Pump (P1) is delayed "Off" as user-defined in the Heater menu and the System Pump (P2) is delayed "Off" in the ADJUST menu, and the integral Boiler / Injection Pump (P1) is delayed "Off" as user-defined in the BOILER menu.

For pipe sizing, see **Table G** and **Table H**.

NOTE: MODE 1 can also be used for process heating applications in conjunction with a buffer/storage tank when operating temperatures above 150°F (66°C) are required. Care must be given to ensure water hardness is no more than 15 grains per gallon for scale free operation.

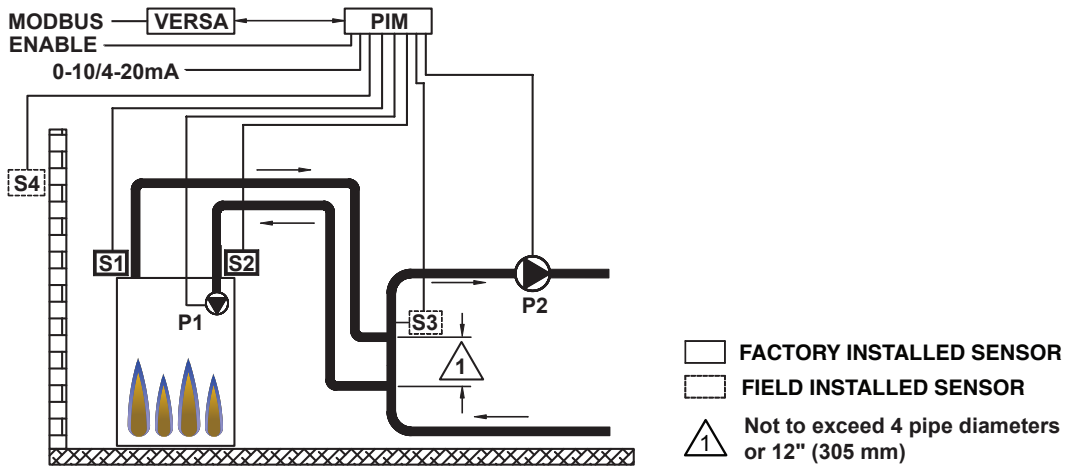

Figure 16. Mode 1 - Single Boiler with Primary/Secondary Piping

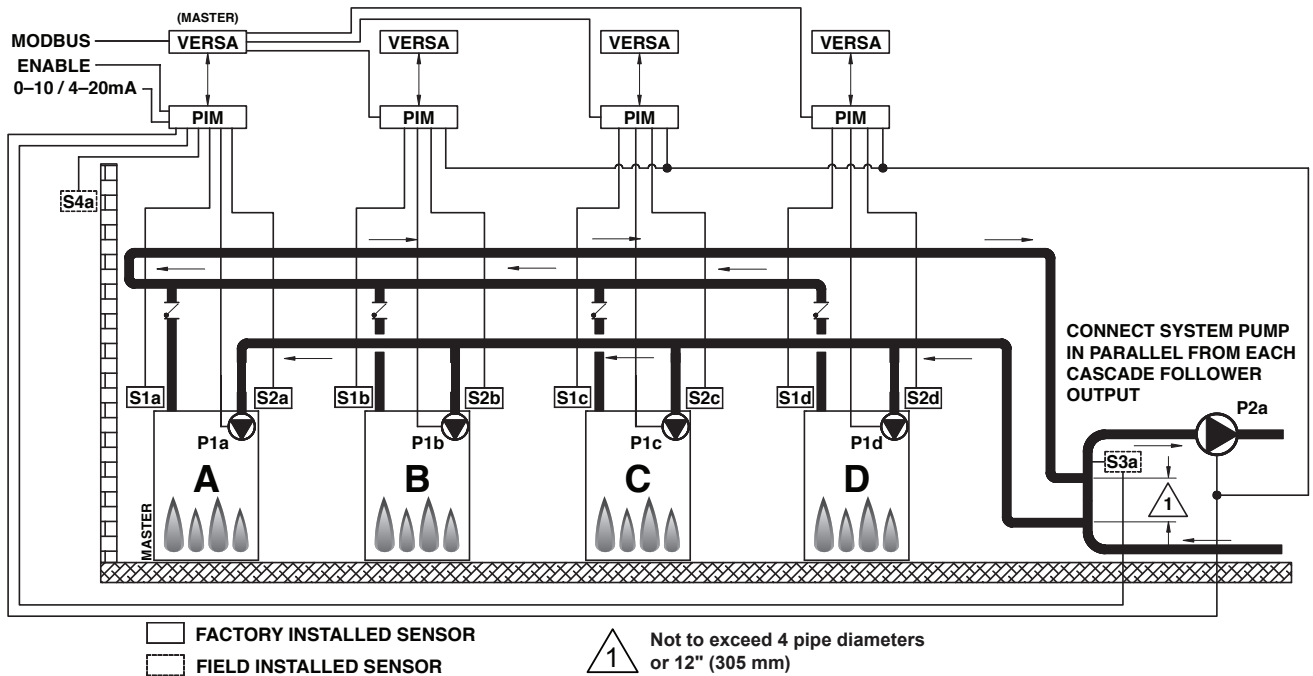

Figure 17. Mode 1 - Boiler Cascade with Primary/Secondary Piping

Mode 2 (Type H Units Only)

This mode selection is for hydronic heating systems with single or multiple boilers (Maximum 4 boilers) in primary/secondary piping configuration with or without Outdoor Air Reset (S4) with indirect DHW on the system loop (with or without priority). The system temperature is controlled by the System sensor (S3). See **Figure 18**.

The Indirect DHW sensor (S5) determines the indirect call/tank setpoint. The system temperature is boosted to Target Max when using the Indirect DHW sensor (S5) during an indirect call for heat.

Priority mode toggles off the System Pump (P2) when an indirect call for heat is present. The Indirect DHW Pump (P3) runs during an indirect call for heat with no “off” delay. The System Pump (P2) delay “off” as user-defined in the ADJUST menu, and the integral Boiler / Injector pump (P1) is delayed “off” as user-defined in the BOILER menu. The System Pump (P2) runs whenever the system is enabled for heating and the outdoor air temperature is lower than the WWSD temperature setting (if utilized) unless an indirect call for heat is present with priority.

For pipe sizing, see **Table G** and **Table H**.

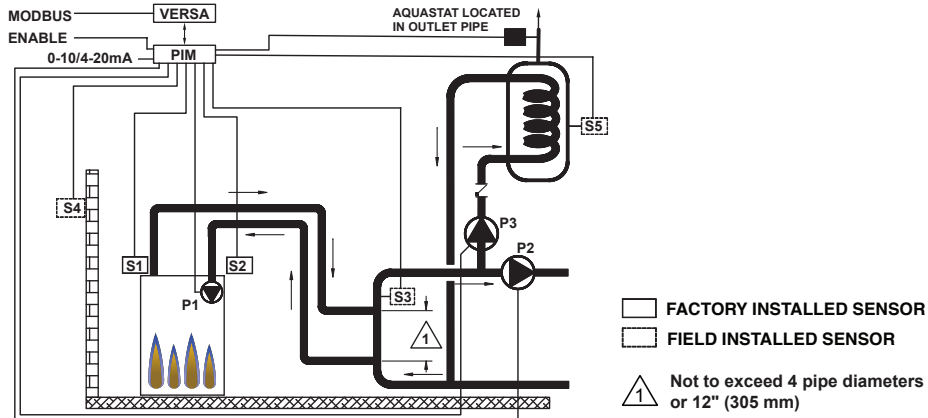

Figure 18. Mode 2 - Single Boiler with Indirect on System Loop

Mode 3

This mode selection is for hydronic heating systems with single or multiple boilers (Maximum 4 boilers) in primary/secondary piping configuration with or without Outdoor Air Reset (S4) with indirect DHW on the boiler loop (with priority). See **Figure 19**.

The system temperature is controlled by the Supply sensor (S3) whenever the indirect call for heat is not active. The indirect DHW Supply sensor (S6) determines the indirect call/tank setpoint. During an indirect call for heat the boiler firing rate is determined by the water temperature at the Indirect Supply sensor (S6) and the Target Max setting when using the Indirect DHW sensor (S5). The Indirect DHW Pump (P3) runs during an indirect call for heat with

no “off” delay. The System Pump (P2) delay “off” as user-defined in the ADJUST menu, and the integral Boiler / Injector pump (P1) is delayed “off” as user-defined in the BOILER menu. The system pump (P2) runs whenever the system is enabled for heating and the outdoor air temperature is lower than the WWSD temperature setting (if utilized) unless an indirect call for heat is present.

For piping Sizing, see **Table G** and **Table H**.

NOTE: A Tank Aquastat can be used in lieu of the Indirect DHW Sensor (S5). See VERSA IC manual (5000.72) for additional details.

NOTE: See VERSA IC manual (5000.72) for more information on cascade systems.

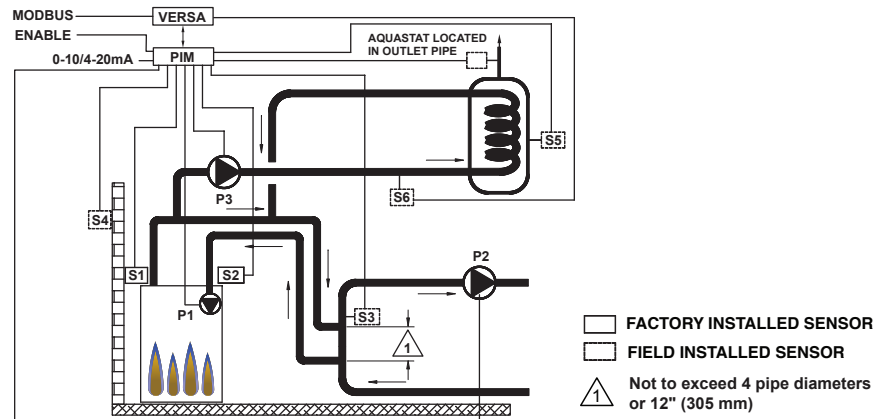

Figure 19. Mode 3 - Single Boiler with Indirect on Boiler Loop

3.9.7. Domestic Hot Water

NOTE: Soft = 3–4 grains per gallon; Medium = 5–15 grains per gallon; Hard = 16–25 grains per gallon.

WH – Direct DHW Configuration

When the unit is ordered as a “WH” configuration, the only application available to it is direct DHW with single or multiple heaters (Maximum 4 heaters). See **Figure 20**. The tank temperature is controlled by the System sensor (S3). The integral Boiler Pumps (P1) run during any call for heat. The System Pump (P2) output is active whenever the system is enabled. The Boiler / Injector Pumps are delayed “off” after the Tank Target temperature is achieved and as user-defined in the **BOILER** menu.

NOTE: If local codes require a vacuum relief valve, acquire one locally and install per valve manufacturer’s instructions.

NOTE: WH units will operate to a maximum setpoint of 150°F (66°C). For temperatures required above 150°F (66°C), an “H” model boiler configured for high-temperature potable operation must be used and great care must be given to ensure water hardness is no more than 15 grains per gallon for scale-free operation. **MODE 1** should be used and configured for setpoint operation for process heating applications.

For DWH pipe sizing, see **Table G** and **Table K**.

3.9.8. Potable Water and Space Heating

⚠ CAUTION: When this heater is used for both potable water and space heating, observe the following to ensure proper operation.

1. All piping materials and components connected to the water heater for the space heating application shall be suitable for use with potable water.
2. Toxic chemicals, such as used for boiler treatment, shall not be introduced into the potable water used for space heating.
3. If the heater will be used to supply potable water, it shall not be connected to any heating system or components previously used with a non-potable water heating appliance.
4. When the system requires water for space heating at temperatures higher than 140°F (60°C), a means such as a mixing valve shall be installed to temper the water in order to reduce scald hazard potential.

Tank/ Return Temp (°F / °C)	Model 1005A				Model 1505A				Model 2005A		
	Soft/Med Sup. Temp ¹ (°F / °C)***	Hard Sup. Temp ¹ (°F / °C)*	Minimum Tubing Size ²		Med Sup. Temp ¹ (°F / °C)	Hard Sup. Temp ¹ (°F / °C)*	Minimum Tubing Size ²		Soft/Med Sup. Temp ¹ (°F / °C)***	Minimum Tubing Size ²	
			<80' equiv.	80-200' equiv.			<80' equiv.	80-200' equiv.		<80' equiv.	80-200' equiv.
60 (15)	138 (59)	135	2"	2-1/2"	145 (63)	143 (62)	2"	2-1/2"	154 (68)	2"	2-1/2"
80 (27)	138 (59)	135	2"	2-1/2"	145 (63)	143 (62)	2"	2-1/2"	154 (68)	2-1/2"	3"
100 (38)	138 (59)	135	2-1/2"	3"	145 (63)	143 (62)	2-1/2"	3"	154 (68)	2-1/2"	3"
120 (49)	146 (63)	146 (63)	2-1/2"	3"	146 (63)	146 (63)	2-1/2"	3"	155 (68)	2-1/2"	3"
130 (54)	156 (69)	156 (69)	2-1/2"	3"	156 (69)	156 (69)	2-1/2"	3"	165 (74)	2-1/2"	3"
140 (60)	166 (74)	166 (74)	2-1/2"	3"	166 (74)	166 (74)	2-1/2"	3"	175 (79)	2-1/2"	3"

¹ Approximate high fire heater outlet temperature based on the standard heater pump and the recommended connecting pipe size.

² Minimum pipe size based on total equivalent feet of supply and return piping between the tank and heater.

WH-1005A - 87 gpm @ 3.5 ft (329 lpm @ 1 m) hd pressure drop
 WH-1505A - 113 gpm @ 7.6 ft (428 lpm @ 2.3 m) hd pressure drop
 WH-2005A - 116 gpm @ 8 ft (439 lpm @ 2.4 m) hd pressure drop

Table K. Hot Water Supply Temperatures and Minimum Pipe Size at Varying Return Temperatures

*Must utilize optional cupro-nickel tubes. If over 25 grains per gallon, a water softener/treatment system must be utilized.

****Caution:** For scale-free operation with “Hard Water” (16-25 grains per gallon of total hardness), the operating control must NOT be set higher than 130°F (54°C). For higher than 130°F (54°C) operation, a water softener/treatment system must be utilized.

***Care should be given to prevent over-softening of the water as over-softened water can become aggressive. Cupro-nickel tubes are recommended for water softened below 5 grains per gallon.

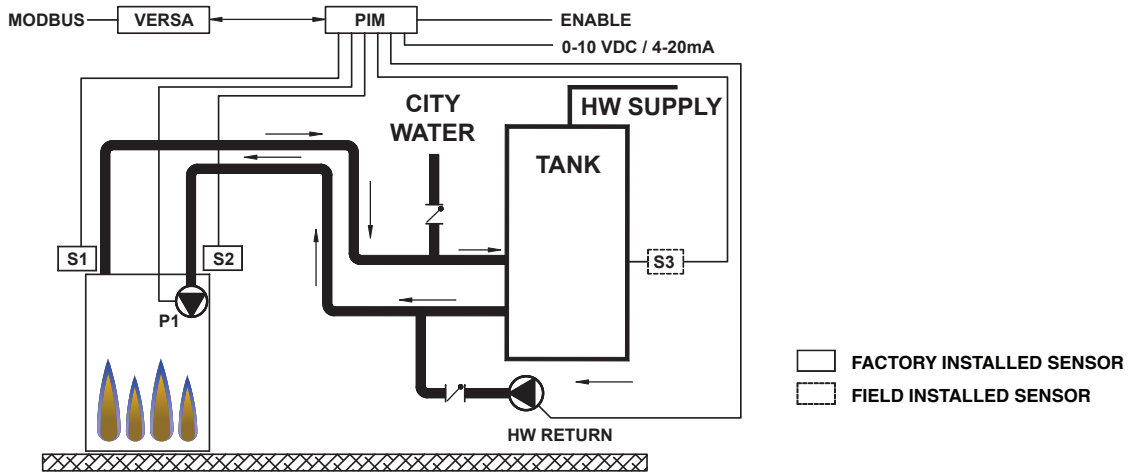

Figure 20. WH Units - Single Water Heater with Tank H Units - Single Boiler with Process Tank

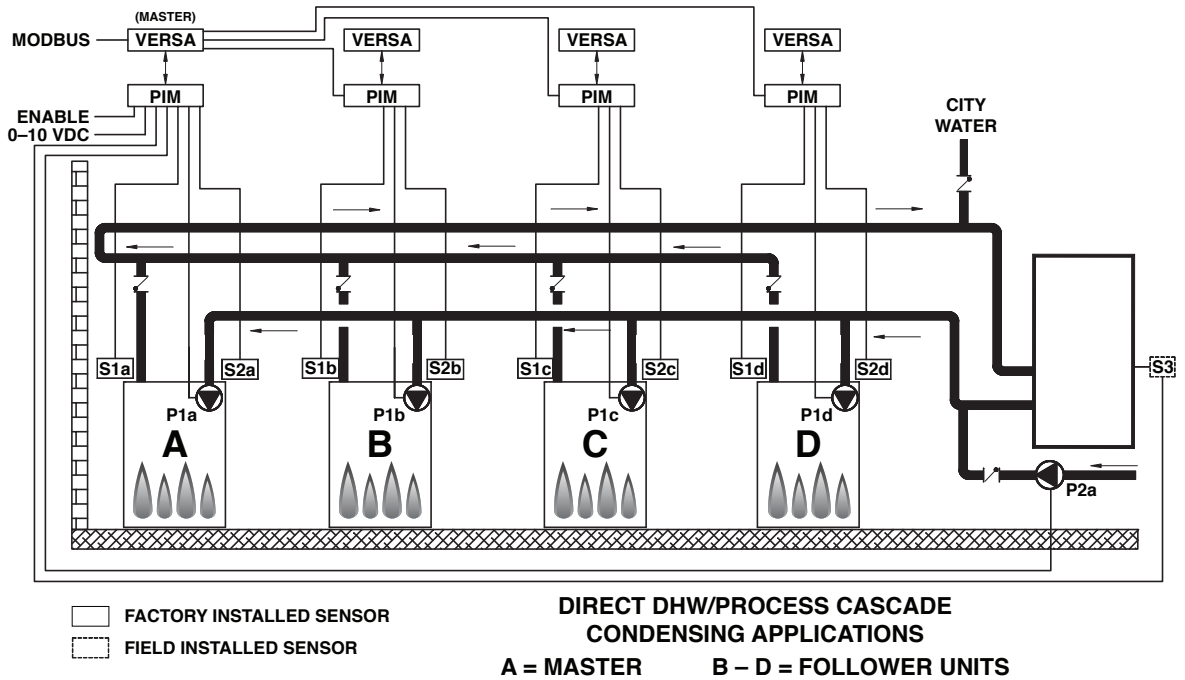

Figure 21. WH Units - Single Water Heater with Tank H Units - Single Boiler with Process Tank

3.9.9. Automatic Chemical Feeders

All chemicals must be introduced and completely diluted into the water before being circulated through the heater. High chemical concentrations will result when the pump is not running (e.g. overnight).

CAUTION: Combustion air must not be contaminated by corrosive chemical fumes which can damage the heater and void warranty.

CAUTION: High chemical concentrations from feeders that are out of adjustment will cause rapid corrosion to the heat exchanger. Such damage is not covered under the warranty.

CAUTION: Failure of a heat exchanger due to lime scale build-up on the heating surface, low pH or other chemical imbalance is non-warrantable.

3.9.10. Pool Heating

When a boiler or water heater is used in a pool heating application, ensure that all the following installation requirements are met. See **Figure 22**.

The XTherm must be equipped with a direct-coupled injector pump for pool applications. The standard integral wet-rotor injector pump system supplied with all H and model 1005A WH XTherm heaters **MUST NOT** be used for pool service. The direct-coupled pump is optional on all H and 1005A WH models, and standard on 1505A and 2005A WH and all P models.

The injector pump must be set to maintain 120°F (49°C) at the inlet to the primary heat exchanger on all XTherm models. To complete installation of the heater, the system sensor must be installed in the return water line, upstream of the heater and wired to the S3 sensor position (TB1, pins 6 and 7).

The onboard VERSA IC operating control is configured to operate as the poolstat. A sensor is shipped loose to be installed in the system piping downstream of the heater outlet. See **Figure 22** for the sensor locations. Wire the sensor to the S6 sensor position (TB1, pins 2 and 3).

For data on acceptable pool chemistry, see **Table L**. For pipe sizing, see **Table G** and **Table K**.

WARNING: To ensure safe operation of the XTherm pool heater, plumbing from the heater outlet to the main loop must be CPVC, copper or brass.

CAUTION: Combustion air must not be contaminated by corrosive chemical fumes which can damage the heater and can cause unwarrantable damage to the heater.

CAUTION: Power to the heater should be interlocked with the main system pump to make sure the heater does not fire without the main system pump in operation. Improper flow control can damage the heater. Uncontrolled flow (too high) or restricted flow (too low) can seriously damage the heater. Follow these instructions to make sure your heater is properly installed.

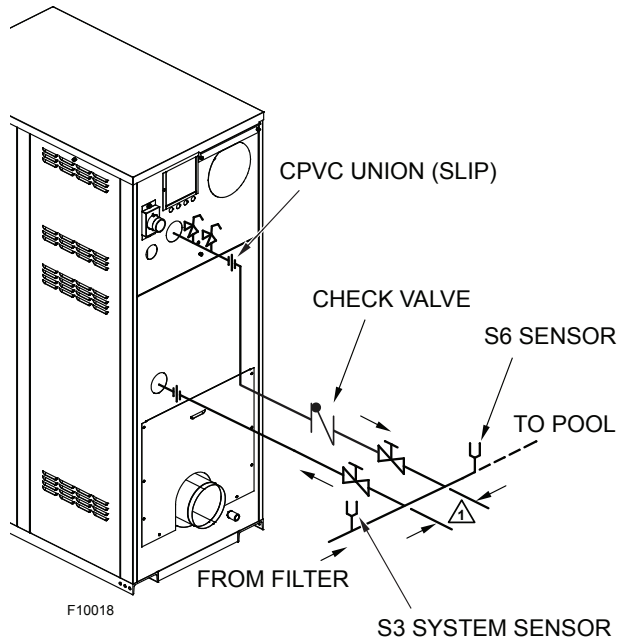

1 Maximum distance not to exceed 4 pipe diameters or 12" (305 mm)

Figure 22. Single Pool Heater Application

3.9.11. Winterizing Your Heater

Heaters installed outdoors as pool heaters in freezing climate areas should be shut down for the winter. To shut down the heater, turn off manual main gas valve and main gas shut-off. Close isolation valves. Drain the heater using the hose bibs located on the bottom of both heat exchangers. Disconnect the condensate hose from the stainless steel condensing heat exchanger and drain the condensate trap.

NOTE: There are 3 separate drains on the XTherm that must ALL be drained to protect the heat exchangers. These are accessible by removing the lower front door from the heater for the 2 primary drains and the right-rear panel for the condensing heat exchanger drain. Drain any piping of all water that may experience below-freezing temperatures.

Recommended Level(s)	Fiberglass Pools	Fiberglass Spas	Other Pool and Spa Types
Water Temperature	68-88°F (20-31°C)	89-104°F (31-40°C)	68-104°F (20-40°C)
pH	7.3-7.4	7.3-7.4	7.6-7.8
Total Alkalinity (ppm)	120-150	120-150	80-120
Calcium Hardness (ppm)	200-300	150-200	200-400
Salt (ppm)	4500 Maximum	4500 Maximum	4500 Maximum
Free Chlorine (ppm)*	2-3	2-3	2-3
Total Dissolved Solids (ppm)	3000 Maximum**	3000 Maximum**	3000 Maximum**

*Free Chlorine **MUST NOT EXCEED 5 ppm!**

**In saltwater chlorinated pools, the total TDS can be as high as 6000 ppm.

Table L. Pool Water Chemistry

3.10. Pool/Spa Water Chemistry

CAUTION: Corrosive water can cause unwarrantable damage to the heater.

NOTE: Chemical imbalance can cause severe damage to your heater and associated equipment.

Chemical imbalance can cause severe damage to the pool heater and associated equipment. Maintain the water chemistry according to the chart below. If the mineral content and dissolved solids in the water become too high, scale forms inside the heat exchanger tubes, reducing heater efficiency and damaging the heater. If the pH drops below 7.2, this will cause corrosion of the heat exchanger and severely damage the heater. Heat exchanger damage resulting from chemical imbalance is not covered by the warranty.

For your health and the protection of your pool equipment, it is essential that your water be chemically balanced. The following levels must be used as a guide for balanced water.

Occasional chemical shock dosing of the pool or spa should not damage the heater providing the water is balanced.

Automatic chemical dosing devices and salt chlorinators are usually more efficient in heated water. If not controlled, they can lead to high chemical levels which can damage your heater.

Further advice should be obtained from your pool or spa builder, accredited pool shop, or chemical supplier for the correct levels for your water.

NOTE: The allowable concentrations of salt and of the Total Dissolved Solids are lower for the XTherm than for a typical residential pool heater, due to the higher water temperatures at which an XTherm operates.

3.10.1. Automatic Chlorinators and Chemical Feeders

All chemicals must be introduced and completely diluted into the water before being circulated through the heater. High chemical concentrations will result when the pump is not running (e.g. overnight).

Chlorinators must feed downstream of the heater and have an anti-siphoning device to prevent chemical back-up into the heater when the pump is shut off.

CAUTION: High chemical concentrations from feeders that are out of adjustment will cause rapid corrosion to the heat exchanger. Such damage is not covered under the warranty.

CAUTION: Failure of a heat exchanger due to lime scale build-up on the heating surface, low pH or other chemical imbalance is non-warrantable.

3.11. Gas Supply

DANGER: Make sure the gas on which the heater will operate is the same type as specified on the heater's rating plate.

CAUTION: Fuel grades of other than HD-5 Propane or Natural Gas (980-1080 BTU/ft³) may require adjustments, please contact the factory.

Gas piping **must** have a sediment trap ahead of the heater gas controls, **and** a manual shut-off valve located outside the heater jacket. It is recommended that a union be installed in the gas supply piping adjacent to the heater for servicing. The gas supply pressure to the heater must not exceed 10.5" WC for natural gas or 13.0" WC for propane gas. A pounds-to-inches regulator must be installed to reduce the gas supply pressure if it is higher than noted above. This regulator should be placed a minimum distance of 10 times the pipe diameter upstream of the heater gas controls. Refer to **Table M** for maximum pipe lengths.

3.11.1. Gas Supply Connection

CAUTION: The heater must be disconnected from the gas supply during any pressure testing of the gas supply system at test pressures in excess of 1/2 psi (3.45 kPa).

During any pressure testing of the gas supply piping system at test pressures of 1/2 psi (3.45 kPa), or less, the heater must be isolated from the gas supply piping system by closing the upstream manual shut-off valve. Relieve test pressure in the gas supply line prior to re-connecting the heater and its manual shut-off valve to the gas supply line. **FAILURE TO FOLLOW THIS PROCEDURE MAY DAMAGE THE GAS VALVE.**

Over-pressurized gas valves are not covered by warranty. The heater and its gas connections shall be leak-tested before placing the appliance in operation. Use soapy water for leak test. DO NOT use an open flame.

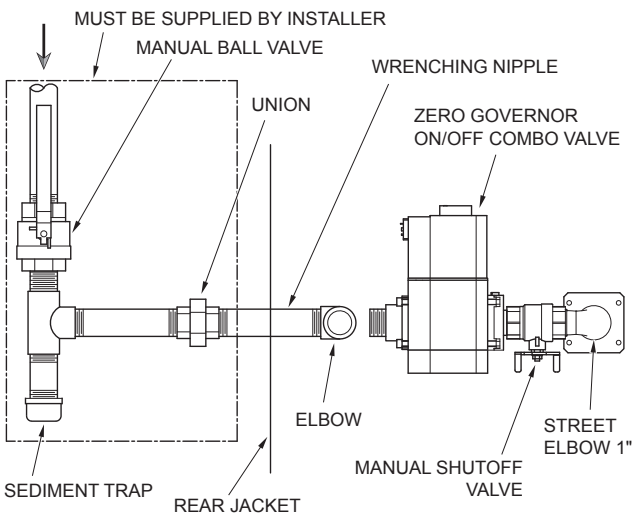

Figure 23. Gas Supply Connection

CAUTION: Only sealant tape or a pipe compound rated for use with natural and propane gases is recommended. Apply sparingly only on male pipe ends, leaving the two end threads bare.

CAUTION: Support gas supply piping with hangers, not by the heater or its accessories. Make sure the gas piping is protected from physical damage and freezing, where required.

3.11.2. Gas Supply Pressure

A minimum of 4" WC and a maximum of 10.5" WC gas pressure is required under load and no-load conditions for natural gas at the heater. A minimum of 4" WC and a maximum of 13" WC is required for propane gas at the heater. The gas pressure regulator(s) supplied on the heater is for low-pressure service. If upstream pressure exceeds these values, an intermediate gas pressure regulator, or the lockup type, must be installed.

When connecting additional gas utilization equipment to the gas piping system, the existing piping must be checked to determine if it has adequate capacity for the combined load.

CAUTION: For proper operation, no more than a 30% drop in gas supply pressure from no-load to full-load conditions is acceptable. Under no circumstances should the pressure be outside the listed operational range.

When connecting additional gas utilization equipment to the gas piping system, the existing piping must be checked to determine if it has adequate capacity for the combined load.

NOTE: During normal operation, carbon dioxide should be 9.3% ± 0.2% at full fire for natural gas and 10.7% ± 0.2% for propane gas. Carbon monoxide should be less than 100 ppm at all firing rates, measured at test port, 12" (30.5 cm) above the flue collar.

Model No.	1-1/4" NPT		1-1/2" NPT		2" NPT		2-1/2" NPT	
	N	P	N	P	N	P	N	P
1005A	35 (10)	55 (17)	35 (10)	90 (27)	125 (38)	300 (91)	300 (91)	
1505A	10 (3)	15 (5)	15 (5)	25 (7)	60 (18)	150 (46)	150 (46)	275 (84)
2005A					35 (10)	90 (27)	85 (26)	210 (64)

Natural Gas – 1,000 BTU/ft³, 0.60 specific gravity at 0.5" WC pressure drop.
Propane Gas – 2,500 BTU/ft³, 1.53 specific gravity at 0.6" WC pressure drop.

Table M. Maximum Equivalent Gas Pipe Length (ft./m)

3.12. Electrical Power Connections

⚠ WARNING: Electrical power connection must be performed by qualified licensed electrician(s) for the voltage being applied.

Installations must follow these codes:

- National Electrical Code and any other national, state, provincial or local codes or regulations having jurisdiction.
- Safety wiring must be NEC Class 1.
- Heater must be electrically grounded as required by the NEC.
- In Canada, CSA C22. 1 C.E.C. Part 1.

XTherm heaters are wired for 120VAC single-phase power. These units come wired with separate connections for the heater and pumps. These connections may be wired to separate circuits, or joined to a single larger circuit.

Models 1005A and 1505A, except WH 1505A models equipped with a heater pump for hard water, require 20A service for the heater and 15A service for the heater pumps, or a single 40A-rated circuit.

WH 1505A heaters equipped for hard water require 15A service for the heater and 25A service for the heater pumps, or a single 50A-rated circuit.

Model 2005A heaters require 25A service for the heater and 25A service for the heater pumps, or a single 50A service.

Consult the wiring diagram shipped with the heater. Use appropriately-sized wire as defined by NEC, CSA and/or local codes. All primary wiring should be rated for 125% of the minimum required service. Before starting the heater, verify that the correct 120VAC voltage is being supplied to the heater and pump.

If any of the original wire supplied with the heater must be replaced, it must be replaced with 105°C or its equivalent.

Power is connected to the heater via the rear wiring box as shown in **Figure 24**. Main heater power is connected to terminals 1, 2 and 3 and pump power is connected to terminals 4, 5 and 6.

Field wiring connections such as sensors, interlocks, enable/disable and alarm contacts are made at the low-voltage terminal strip at the front of the heater as shown in **Figure 29**.

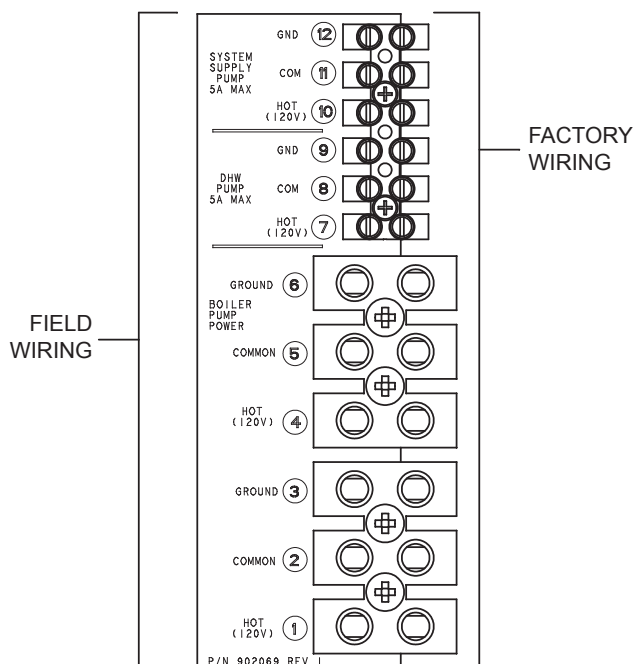

Figure 24. Wiring Electrical Connections

3.12.1. Field Connected Devices

It is strongly recommended that all individually-powered control modules and the heater should be supplied from the same power source.

Install heater controls, thermostats, or building management systems in accordance with the applicable manufacturers' instructions.

⚠ NOTE: Field-supplied isolation relays should be installed when field-connected controllers are mounted more than 50 equivalent feet (18 AWG) from heater. See wiring diagrams.

NOTE: Minimum 18 AWG, 105°C, stranded wire must be used for all low voltage (less than 30 volts) external connections to the heater. Solid conductors should not be used because they can cause excessive tension on contact points. Install conduit as appropriate. All high voltage wires must be the same size (105°C, stranded wire) as the ones on the unit or larger.

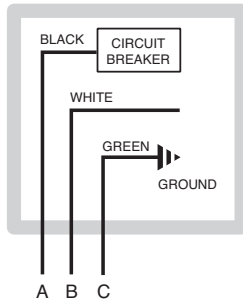

Figure 25. Wiring Connections

⚠ WARNING: Using a multi-meter, check the following voltages at the circuit breaker panel prior to connecting any equipment. Make sure proper polarity is followed and house ground is proven. (See Figs. 22-24.)

Check the power source:

AC = 108 VAC Minimum, 132 VAC MAX

AB = 108 VAC Minimum, 132 VAC MAX

BC = <1 VAC Maximum

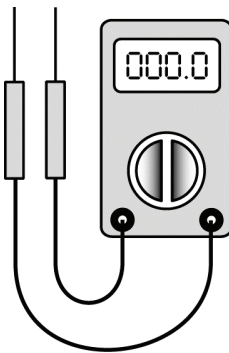

Figure 26. Multi-meter

3.12.2. Making the Electrical Connections

Refer to **Figure 24** through **Figure 28**.

1. Verify that circuit breaker is properly sized by referring to heater rating plate. A dedicated circuit breaker should be provided.
2. NOTE: Current draw noted on rating plate does not include pump current.
3. Turn off all power to the heater. Verify that power has been turned off by testing with a multi-meter prior to working with any electrical connections or components.
4. Observe proper wire colors while making electrical connections. Many electronic controls are polarity sensitive. Components damaged by improper electrical installation are not covered by warranty.
5. Provide overload protection and a disconnect means for equipment serviceability as required by local and state code.

6. Install heater controls, thermostats, or building management systems in accordance with the applicable manufacturers' instructions.
7. Conduit should not be used as the earth ground.

NOTE: A grounding electrode conductor shall be used to connect the equipment grounding conductors, the equipment enclosures, and the grounded service conductor to the grounding electrode.

3.13. Field Wiring Connections

⚠ CAUTION: Label all wires prior to disconnection when servicing controls. Wiring errors can cause improper and dangerous operation. Verify proper operation after servicing.

⚠ DANGER: SHOCK HAZARD

Make sure electrical power to the heater is disconnected to avoid potential serious injury or damage to components.

3.13.1. Wiring the Enable/Disable

Connect the Enable/Disable (terminals 11 and 12) wiring to the field wiring terminals as shown in **Figure 29**. Alternately, any dry contact closure (including a remote thermostat) across these terminals will enable the XTherm heater to run.

⚠ CAUTION: Ensure neither of the terminals are shorted to ground.

3.13.2. Wiring the Outdoor Sensor

1. If using an Outdoor Sensor, connect the sensor wires to the terminals (8 and 9) marked OUTDOOR SENSOR. See **Figure 29**.

⚠ CAUTION: Ensure sensor wiring is not shorted to ground.

2. Use a minimum 18 AWG stranded wire for runs of up to 150 ft (46 m).
3. Mount the outdoor sensor on an exterior surface of the building, preferably on the north side in an area that will not be affected by direct sunlight and that will be exposed to varying weather conditions.

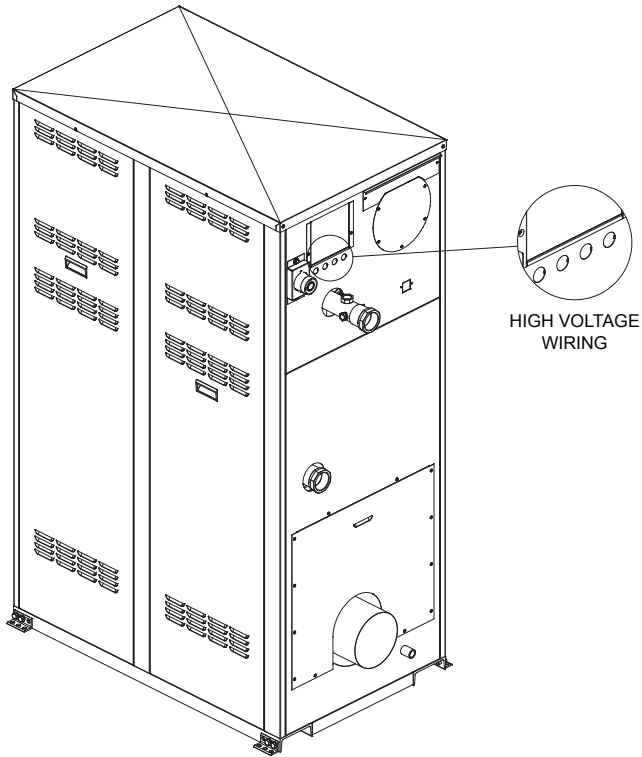

Figure 27. Wiring Location - High Voltage

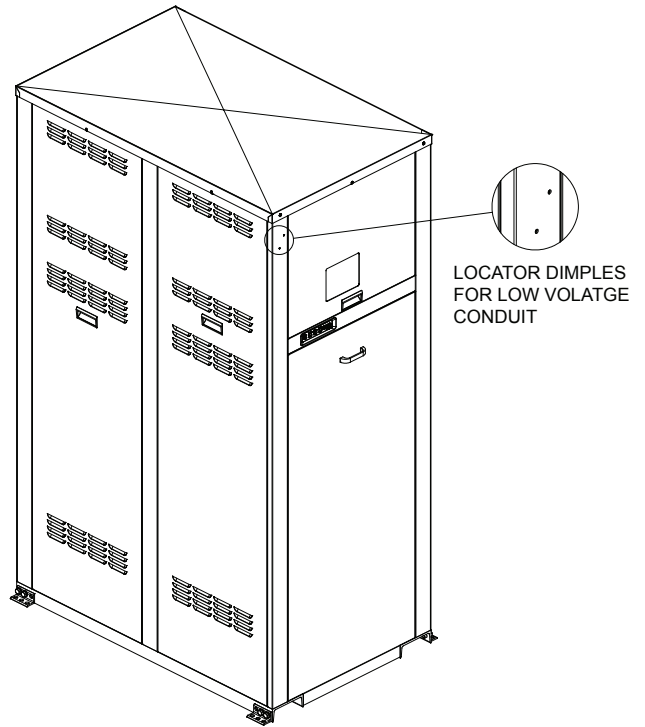

Figure 28. Locator Dimples for Low-Voltage Conduit

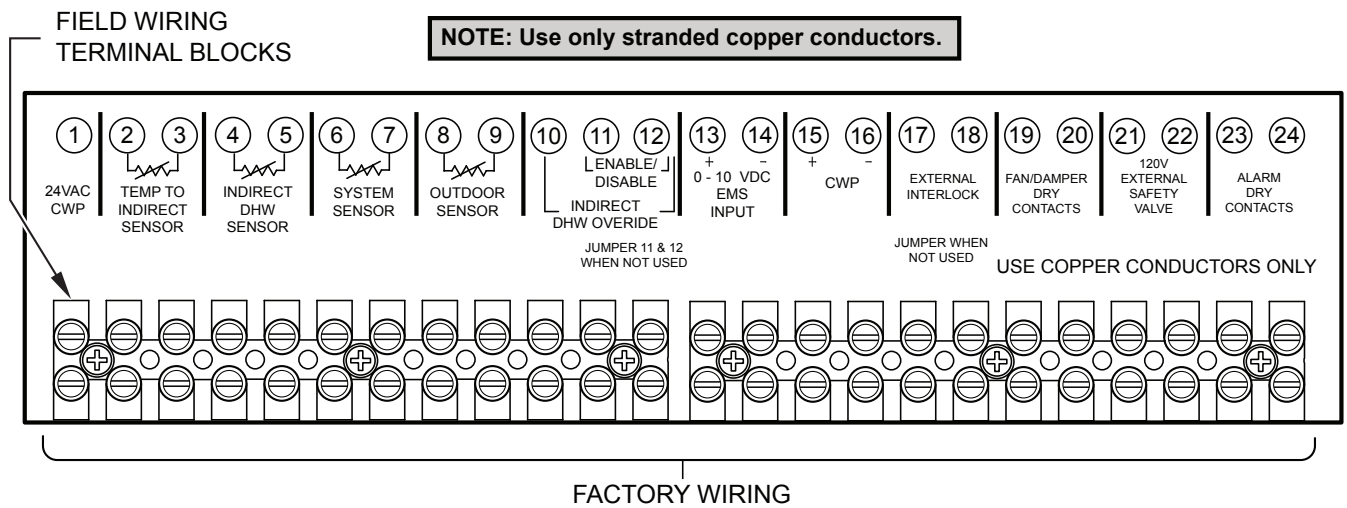

Figure 29. Low-Voltage Wiring

3.13.3. Wiring the Indirect Sensor

1. An indirect sensor connection is not required if an indirect water heater is not used in the installation.
2. When the Indirect DHW call for heat is active, the PIM communicates this to the VERSA. The VERSA calculates the optimal operation and sends the firing rate and pump output requests to the PIM so it can activate the Indirect DHW pump and Boiler pumps as needed. If an optional Indirect DHW sensor is connected, the PIM will pass this signal to the VERSA. This allows the VERSA to optimize the Indirect DHW demand to maintain the Indirect DHW setpoint. The Indirect DHW thermostat switch closure is still required when using the Indirect DHW sensor. If a VERSA is not present the PIM shall activate the Indirect DHW pump whenever the Indirect DHW call is active. The Boiler pump will also be activated based on the Indirect DHW piping configuration setting. Consult the VERSA IC manual (5000.72) for additional configurations.
3. Connect the indirect tank sensor to the terminals marked INDIRECT DHW SENSOR. See the wiring diagram on **page 47**. Caution should be used to ensure neither of these terminals becomes connected to ground. When using an indirect DHW sensor to control tank temperature, contact closure is required across the indirect override connections for proper operation.

NOTE: Alternately, a thermostat contact closure can be used in lieu of the sensor for indirect operation. Connect the thermostat to the terminals (10 and 12) marked INDIRECT DHW OVERRIDE.

CAUTION: Sensor and control wiring must NOT be run in chases with line voltage.

CAUTION: To prevent an over-temperature condition from occurring in the indirect DHW system during "limp-along" operation, set PIM operator dial to be equal to DHW Target temperature. See VERSA IC manual (5000.72) for more information on "limp-along" operation.

3.13.4. Wiring the Optional 0–10 Volt Building Control Signal

1. A signal from an energy management system may be connected to the boiler. This signal should be a 0-10 volt positive DC signal. The energy management system can be used to control either the setpoint temperature of a single boiler or a cascade of up to 4 boilers, or the firing rate of a single boiler.
2. To enable this remote control function, set DIP switch 5 to the UP position on the PIM. DIP switch 5 Toggles between an EMS (UP) signal or a demand signal from the VERSA (DOWN).

3. DIP switch 2 on the PIM toggles between a Direct Drive (UP) input and a Target Temperature (DOWN) setpoint.
4. For a 4-20mA application, refer to the VERSA IC manual (5000.72).
5. Connect an Energy Management system or other auxiliary control signal to the terminals marked 0-10V (+/-) on the field wiring terminals. See **Figure 29**. Caution should be used to ensure that the +0-10V connection does not create a short to ground.
6. Contact closure across the Enable/Disable connection is required for boiler operation in this configuration.

CAUTION: Ensure that the +0-10V connection does not create a short to ground. +0-10V signal is polarity sensitivity and must not be reversed. +0-10VDC signal must not exceed 10VDC.

3.13.5. Wiring the Cascade System - Communication Bus

NOTE: Use unshielded 18 gauge stranded copper wire for proper operation.

1. Designate the primary heater as the master heater/ heater1 by leaving DIP switch 2 on the VERSA in the ON position. All other VERSA controls require DIP switch 2 to be toggled OFF, designating them as followers. Follower VERSA boards are ignored by their corresponding PIM modules. Use standard 18 AWG wire to connect the master VERSA to the PIM on the followers. A total of 3 followers can be connected to the VERSA on the master. For systems requiring more than 4 connected heaters, an external sequencer such as the Raypak Temp-Tracker Mod+ Hybrid can be used.
2. It is recommended that the shortest length cascade wiring possible be used to reach between the heaters. Do not run unprotected cascade wiring across the floor or where they will become wet or damaged. Do not run cascade wiring parallel with, or close to or against, high voltage (120 volt or greater) wiring. Raypak recommends that the total maximum length of each set of cascade wiring not exceed 200' (61 m).
3. Connect the FT_BUS wires to the PIM by pressing down on the slots with a small screwdriver and then inserting the wires into the holes. See **Figure 30**. Fault will occur if wires are reversed.

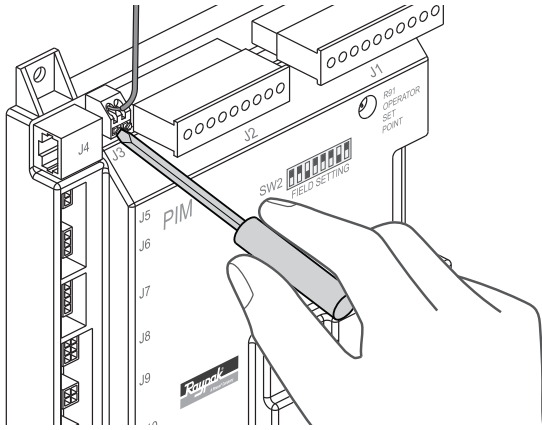

Figure 30. FT_BUS Wire Connection

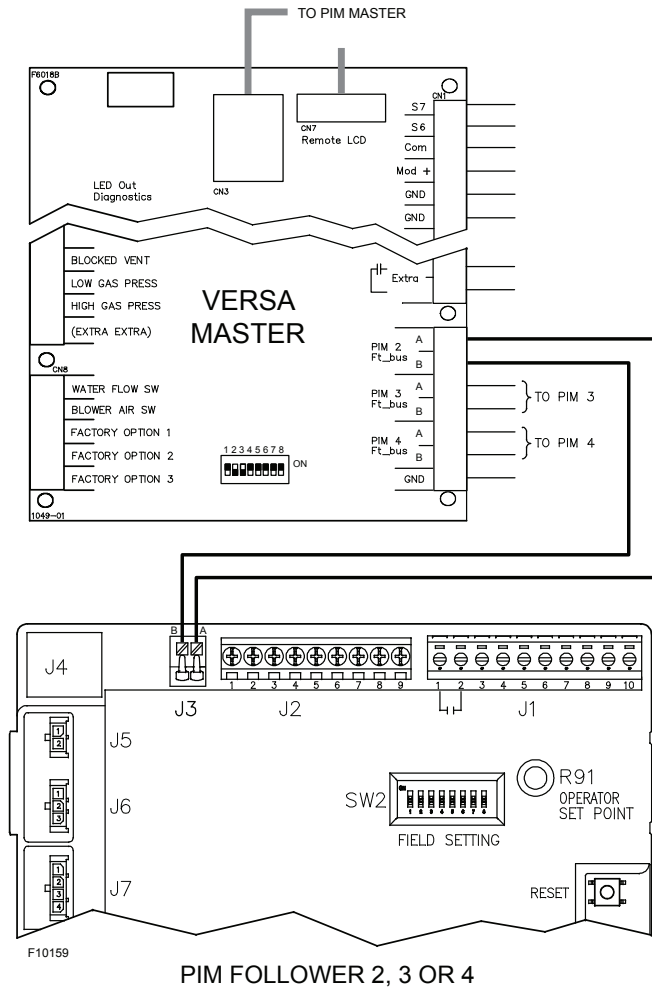

Figure 31. XTherm Cascade System Wiring

3.13.6. Cascade System Pump and Sensor Wiring

1. On the heater designated as the Master, connect the system pump enable wiring to the field-wiring terminal block inside the junction box. The connections are dry contacts rated for pilot duty only (5A maximum). See Figure 32.

2. Connect the system supply sensor to terminals 6 and 7 on the field wiring strip located on the Master heater. See Figure 29.

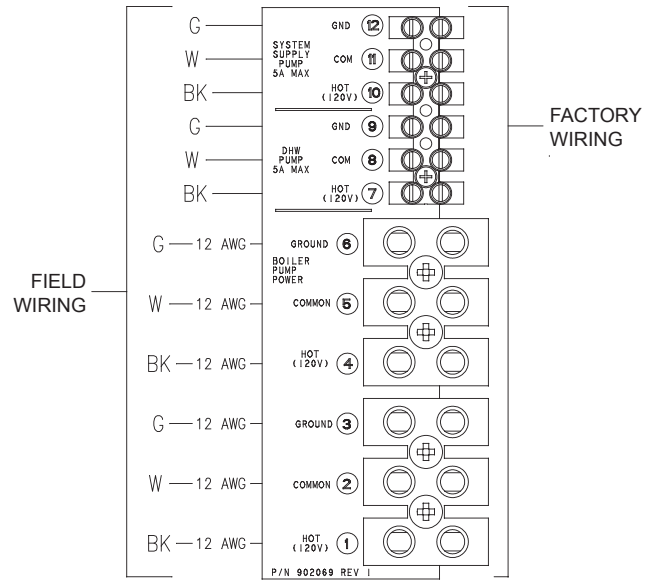

Figure 32. Cascade Master-Pumps

3. Connect the Outdoor sensor (if used) to terminals 8 and 9 on the field wiring strip located on the Master heater. See Figure 29.
4. Connect the Enable/Disable wiring to terminals 11 and 12 on the field wiring strip located on the Master heater. This connection must be provided through dry contacts closure. See Figure 29. Applying 24VAC to these terminals will result in blowing the fuse on PIM.

NOTE: The dry contacts closure can come from a room thermostat or a remote relay. No power of any kind should be applied to either of these terminals.

3.13.7. Cascade Follower Pump and Sensor Wiring

1. Once the primary heater has been identified, additional heaters will be designated as follower heaters. Ensure DIP switch 2 on each follower VERSA is set to the OFF/Down position. See Figure 33.
2. The System and DHW pump outputs are not used in the Cascade Follower configuration. For Cascade configuration System pump (All models) and DHW pump (H models only) follower outputs must be connected in parallel respectively in order to support operation during “limp along” mode. For detailed wiring instructions see VERSA IC manual (5000.72).

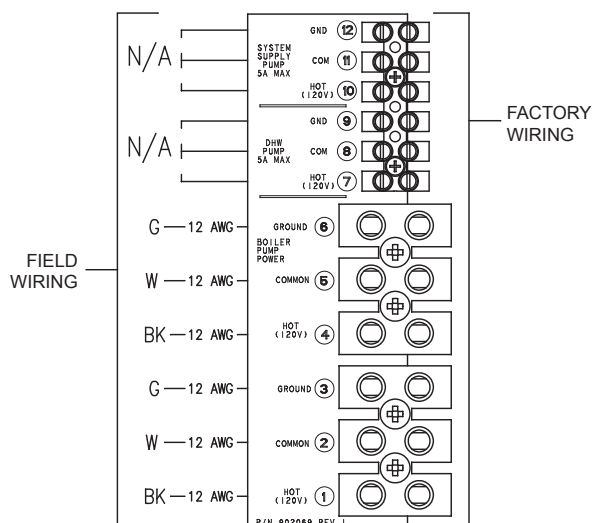

Figure 33. Cascade Follower

3.13.8. Modbus BMS Communication

The VERSA IC control is equipped as standard with a communications port for connectivity to building automation via Modbus protocol. Refer to the VERSA IC manual (5000.72) for further information.

3.13.9. Alarm Connection

An alarm annunciator or light may be connected to the alarm contacts on the field wiring terminal strip. The Alarm Contacts are 3A rated dry contacts on a normally-open relay that close during fault or lockout conditions, and the maximum voltage across the contacts is 30 VAC or 30 VDC. See Figure 29.

In a cascade system with an alarm condition at one or more units, all alarm contacts within the cascade will be energized indicating a fault condition.

3.14. Venting - General

CAUTION: Proper installation of flue venting is critical for the safe and efficient operation of the heater.

NOTE: Raypak strongly recommends installing the vent system before water piping. This will ensure that the venting system and associated components will fit into the allotted space for proper operation.

3.14.1. Appliance Categories

Heaters are divided into four categories based on the pressure produced in the exhaust and the likelihood of condensate production in the vent.

Category I – A heater which operates with a non-positive vent static pressure and with a vent gas temperature that avoids excessive condensate production in the vent.

Category II – A heater which operates with a non-positive vent static pressure and with a vent gas temperature that may cause excessive condensate production in the vent.

Category III – A heater which operates with a positive vent pressure and with a vent gas temperature that avoids excessive condensate production in the vent.

Category IV – A heater which operates with a positive vent pressure and with a vent gas temperature that may cause excessive condensate production in the vent.

See Table N for appliance category requirements.

NOTE: For additional information on appliance categorization, see appropriate ANSI Z21 Standard and the NFGC (U.S.), or B149 (Canada), or applicable provisions of local building codes.

WARNING: Mixing of different manufacturer's venting material is not permitted as this may create an unsafe condition.

CAUTION: Condensate drains for the vent piping are required for installations of the XTherm. Follow vent manufacturer instructions for installation and location of condensate drains in the vent. Condensate drain must use a trap and the trap must be primed with water to prevent flue gas leakage and must be routed to an appropriate container for treatment before disposal, as required by local codes.

WARNING: Contact the manufacturer of the vent material if there is any question about the appliance categorization and suitability of a vent material for application on a Category IV vent system. Using improper venting materials can result in personal injury, death or property damage.

WARNING: Condensate is acidic and highly corrosive.

Centrotherm™ polypropylene vent material is approved to be used on XTherm products. A field-installed vent adapter supplied by Raypak (option D-33) must be used to ensure a proper seal of the flue and condensate. The D-33 kit includes a required vent temperature limit.

3.14.2. Support of Vent Stack

The weight of the vent stack or chimney must not rest on the heater vent connection. Support must be provided in compliance with applicable codes. The vent should also be installed to maintain proper clearances from combustible materials. Use insulated vent pipe spacers where the vent passes through combustible roofs and walls.

NOTE: The XTherm heater is supplied with a vent connector that MAY require a specific vent starter adapter to mate to certified Cat IV stainless steel vent materials (see Table N). This vent starter adapter is supplied by the vent manufacturer to adapt to the various venting systems.

NOTE: The following stainless steel vent manufacturers are certified for use on these heaters. DO NOT use any manufacturer of stainless steel vent systems not listed here. M&G Duravent (FasNSeal Vent), Heat Fab (Saf-T-Vent EZ Seal) and Z Flex (Z-Vent).

NOTE: Installation of a stainless steel vent systems shall adhere to the stainless steel vent manufacturer's installation instructions supplied with the vent system. Please contact the vent manufacturer with any questions.

The XTherm (1005A-2005A) are supplied with an integral Fas-N-Seal vent connector. The installer must use a specific vent starter adapter (supplied by the vent manufacturer).

Model No.	M&G Duravent – “Fas-N-Seal”			
	Air Intake Terminal	Vent Terminal	Vent Pipe	Vent Adapter
1005A	810003281	810003282	6” Fas-N-Seal 6” to 3’ Lengths	810003974
1505A	810003369	*D-15 8” (006646)	8” Fas-N-Seal 6” to 3’ Lengths	810003980
2005A				

Model No.	Heat Fab – Saf-T Vent EZ Seal				
	Air Intake Terminal	Vent Terminal	Vent Pipe	Vent Adapter	
1005A	9614TERM	9690TEE	6” Saf-T vent 6” to 4’ Lengths	9601RYPK	5601BOI
1505A	9814TERM	9890TEE	8” Saf-T vent 6” to 4’ Lengths	9801RYPK	5601BOI
2005A					

Model No.	Z Flex – “Z Vent”			
	Air Intake Terminal	Vent Terminal	Vent Pipe	Vent Adapter
1005A	2SVEE0690	2SVSRTX06	6” Z vent 6” to 4’ Lengths	2SVSA06
1505A	2SVEE0890	2SVSRTX08	8” Z vent 6” to 4’ Lengths	2SVSA08
2005A				

*D-15 Vent Terminal MUST be ordered from Raypak.

Table N. Certified Stainless Steel Terminations and Adaptors - Category IV

3.15. Vent Terminal Location

1. Condensate can freeze on the vent cap. Frozen condensate on the vent cap can result in a blocked flue condition.

⚠ WARNING: All venting types must be of the same material or product throughout the entire exhaust installation to ensure proper securing and sealing.

2. Give special attention to the location of the vent termination to avoid possibility of property damage or personal injury.
3. Gases may form a white vapor plume in winter. The plume could obstruct a window view if the termination is installed near windows.
4. Prevailing winds, in combination with below-freezing temperatures, can cause freezing of condensate and water/ice build-up on buildings, plants or roofs.
5. The bottom of the vent terminal and the air intake shall be located at least 12" (305 mm) above grade, including normal snow line.
6. Un-insulated single-wall Category IV metal vent pipe shall not be used outdoors in cold climates for venting gas-fired equipment.
7. Through-the-wall vents for Category IV appliances shall not terminate over public walkways or over an area where condensate or vapor could create a nuisance or hazard or could be detrimental to the operation of regulators, relief valves, or other equipment.
8. Locate and guard vent termination to prevent accidental contact by people or pets.
9. DO NOT terminate vent in window well, stairwell, alcove, courtyard or other recessed area.
10. DO NOT terminate above any door, window, or gravity air intake. Condensate can freeze, causing ice formations.
11. Locate or guard vent to prevent condensate from damaging exterior finishes. Use a rust-resistant sheet metal backing plate against brick or masonry surfaces.
12. DO NOT extend exposed vent pipe outside of building beyond the minimum distance required for the vent termination. Condensate could freeze and block vent pipe.

3.15.1. U.S. Installations

Refer to the latest edition of the National Fuel Gas Code.

Vent termination requirements are as follows:

1. Vent must terminate at least 4' (1.2 m) below or 4' (1.2 m) horizontally from, window or gravity air inlet to the building.

2. The vent must not terminate above public walkways due to slip hazard from frozen condensate.
3. Terminate vent at least 3' (915 mm) above any forced air inlet located within 10' (3 m).
4. Vent must terminate at least 4' (1.2 m) horizontally, and in no case above or below unless 4' (1.2 m) horizontal distance is maintained, from electric meters, gas meters, regulators, and relief equipment.
5. Terminate vent at least 6' (1.8 m) away from adjacent walls.
6. DO NOT terminate vent closer than 5' (1.5 m) below roof overhang.
7. The D-15 sidewall vent terminal requires a 12" (305 mm) vent terminal clearance from the wall.

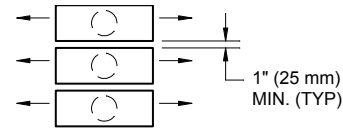

VENT CAPS STACKED VERTICALLY
FLUE GASES MOVING IN PARALLEL

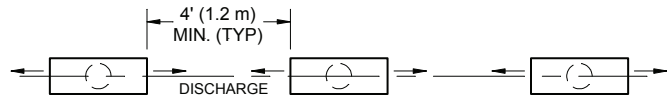

VENT CAPS ALL AT SAME ELEVATION
FLUE GASES MOVING TOWARD EACH OTHER

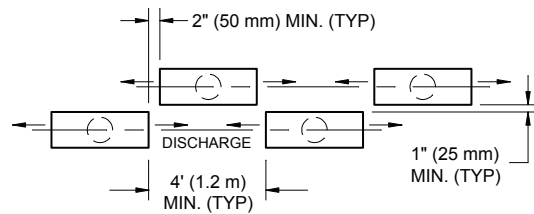

VENT CAPS AT STAGGERED ELEVATIONS
FLUE GASES MOVING TOWARD EACH OTHER

Figure 34. Multiple Sidewall Vent Cap Configurations

8. Terminate vent at least 1' (305 mm) above grade, including normal snow line.
9. Multiple direct-vent installations require a 4' (1.2 m) clearance between the ends of vent caps located on the same horizontal plane.

⚠ WARNING: The Commonwealth of Massachusetts requires that sidewall vented heaters, installed in every dwelling, building or structure used in whole or in part for residential purposes, be installed using special provisions as outlined on page 58 of this manual.

Combustion Air Supply	Exhaust Configuration	Heater Venting Category	Certified Materials	Combustion Air Inlet Material
From Inside Building (Non-Direct Venting)	Vertical Venting	IV	CAT IV Stainless Steel PVC CPVC Polypropylene*	
	Horizontal Through-the-Wall Venting			
From Outside Building (Direct Venting)	Vertical Venting			Galvanized Steel
	Horizontal Through-the-Wall Venting			PVC ABS CPVC

* Only Centrotherm polypropylene material is approved for use with the XTherm.

Table O. Venting Category Requirements

3.15.2. Canadian Installations

Refer to latest edition of the B149 Installation Code.

A vent shall not terminate:

1. Directly above a paved sidewalk or driveway which is located between two single-family dwellings and serves both dwellings.
2. Within 6' (1.8 m) of a mechanical air supply inlet to any building.
3. Above a meter/regulator assembly within 3' (915 mm) horizontally of the vertical centre-line of the regulator.
4. Within 6' (1.8 m) of any gas service regulator vent outlet.
5. Less than 1' (305 mm) above grade level.
6. Within 3' (915 mm) of a window or door which can be opened in any building, any non-mechanical air supply inlet to any building or the combustion air inlet of any other appliance.
7. Underneath a verandah, porch or deck, unless the verandah, porch or deck is fully open on a minimum of two sides beneath the floor, and the distance between the top of the vent termination and the underside of the verandah, porch or deck is greater than 1' (305 mm).

3.16. Venting Installation Tips

Support piping (See vent manufacturers instructions):

- horizontal runs—at least every 5' (1.5 m)
- vertical runs—use braces at least every 10' (3 m)
- under or near elbows

⚠ WARNING: Examine the venting system at least once a year. Check all joints and vent pipe connections for tightness, corrosion or deterioration.

3.17. Vertical Venting Configurations

For heaters connected to gas vents or chimneys, vent installations shall be in accordance with the NFGC (U.S.), or B149 (Canada), or applicable provisions of local building codes.

⚠ CAUTION: This venting system may require the installation of supplemental condensate drains in the vent piping per the vent manufacturer's instructions. Failure to install these condensate drains in the venting system may cause a non-warrantable failure. Condensate must not be allowed to freeze. Take appropriate measures.

Model No.	Certified Vent Material	Vent Size (in.)	Total Effective Length ¹ (ft/m)*		Combustion Air Intake Pipe Material	Air Inlet Max. Length* (ft/m)		
			Min.	Max.		6" Ø	8" Ø	10" Ø
1005A	Category IV Stainless Steel PVC CPVC Polypropylene***	6	0	75 ² (23 ²)	Galvanized Steel, PVC, ABS, CPVC	45 (14)	100** (30)	
1505A		8						
2005A							45 (14)	85** (26)

¹ Vent lengths are based on a lateral length of 2 ft. (0.6 m) Refer to the latest edition of the NFGC for further details.

² Consult factory for longer vent runs.

* Subtract 10 ft (3 m) per elbow. Max. 4 elbows.

** Adapters supplied by others.

*** Only Centrotherm™ polypropylene material is approved for use with the XTherm.

Table P. Category IV Vertical Venting

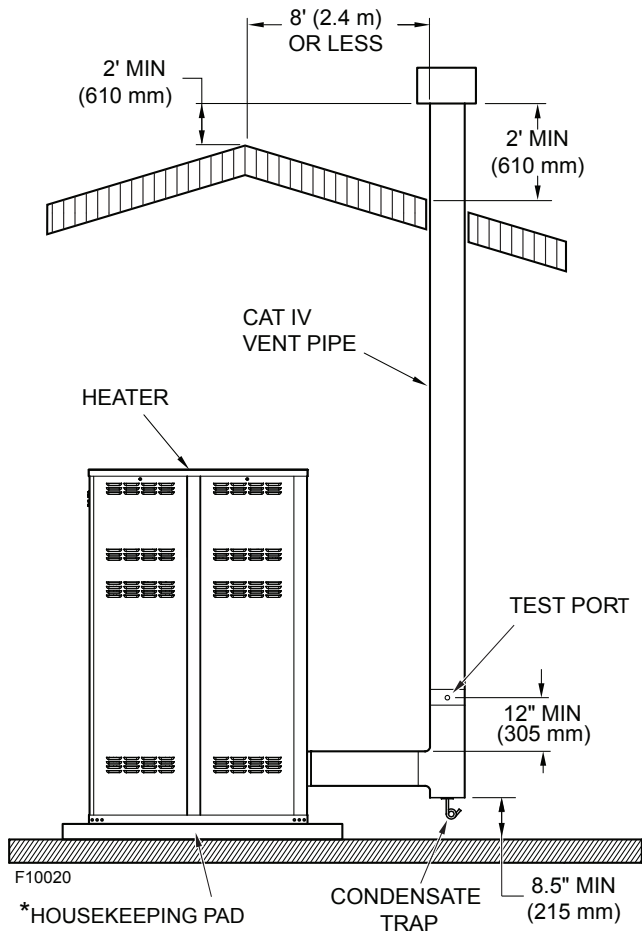

* See Figure 6 on page 8.

Figure 35. Vertical Venting Installation

3.17.1. Installation

The maximum and minimum venting length for this Category IV appliance shall be determined per **Table P**.

The minimum flue pipe diameter for conventional venting using Category IV, stainless steel vent is: 6" (152 mm) for Model 1005A and 8" (203 mm) for Models 1505A and 2005A.

The connection from the appliance vent to the stack must be as direct as possible and shall be the same diameter as the vent outlet. The horizontal breaching of a vent must have an upward slope of not less than 1/4 inch per linear foot from the heater to the vent terminal. The horizontal portions of the vent shall also be supported for the design and weight of the material employed to maintain clearances and to prevent physical damage or separation of joints. The expected flue pressure is approximately 0.5" WC positive.

3.17.2. Termination

The vent terminal must be vertical and must terminate outside the building at least 2' (0.6 m) above the highest point of the roof that is within 8' (2.4 m). The vent cap should have a minimum clearance of 4' (1.2 m) horizontally

from and in no case above or below (unless a 4' [1.2 m] horizontal distance is maintained) electric meters, gas meters, regulators and relief equipment.

The distance of the vent terminal from adjacent buildings, open windows and building openings must comply with the NFGC (U.S.) or B149 (Canada). Gas vents supported only by flashing and extended above the roof more than 5' (1.5 m) should be securely guyed or braced to withstand snow and wind loads.

⚠ CAUTION: A listed vent cap terminal suitable for connection to the Cat IV vent materials, adequately sized, must be used to evacuate the flue products from the building.

⚠ WARNING: Vent connectors serving any other appliances shall not be connected into any portion of mechanical draft systems operating under a positive pressure. If an XTherm heater is installed to replace an existing heater, the vent system **MUST** be verified to be of the correct size and of Category IV UL Listed stainless steel vent material construction or other approved vent materials noted in Table N. If it is **NOT**, it **MUST** be replaced.

NOTE: For extractor sizing, typical CO₂ levels are 9.0% for natural gas and 10.2% and flue temperature of 150°F (66°C).

Model No.	Vent Size in. (mm)	Volume of Flue Products (CFM)
1005A	6 (152)	260
1505A	8 (203)	390
2005A	8 (203)	520

* NOTE: Data for 100% with range between min/max vent length.

Table Q. Volume of Flue Products Data

3.18. Horizontal Through-the-Wall and Direct Vent (Category IV)

NOTE: While a drain connection is required in the vent of all XTherm installations, the drain can be accomplished in several different ways. The figures in this manual show the drain in a vent tee, however, this can also be accomplished using an inline collector for condensing stacks or an inline vertical or horizontal collector available from several of the listed vent manufacturers.

⚠ CAUTION: This venting system may require the installation of supplemental condensate drains in the vent piping per the vent manufacturer's instructions. Failure to install these condensate drains in the venting system may cause a non-warrantable failure. Condensate must not be allowed to freeze. Take appropriate measures.

3.18.1. Installation

These installations utilize the heater-mounted blower to vent the combustion products to the outdoors. Combustion air is taken from inside the room and the vent is installed horizontally through the wall to the outdoors. Adequate combustion and ventilation air must be supplied to the equipment room in accordance with the NFGC (U.S.) or B149 (Canada). The total length of the horizontal through-the-wall flue system should not exceed 75 equivalent ft (23 m) in length. If horizontal run exceeds 75 equivalent ft (23 m), an appropriately-sized variable-speed extractor must be used. Each elbow used is equal to 10' (3 m) of straight pipe. This will allow installation in one of the four following arrangements:

- 75' (23 m) of straight flue pipe
- 65' (20 m) of straight flue pipe and one elbow
- 55' (17 m) of straight flue pipe and two elbows
- 45' (14 m) of straight pipe and three elbows

The vent cap is not considered in the overall length of the venting system.

The vent must be installed to prevent flue gas leakage. Care must be taken during assembly to ensure that all joints are sealed properly and are airtight. The vent must be installed to prevent the potential accumulation of condensate in the vent pipes. It is required that:

1. The vent must be installed with a condensate drain located in proximity to the heater as directed by the vent manufacturer.
2. The vent must be installed with a slight upward slope of not less than 1/4" per foot of horizontal run to the vent terminal.
3. The vent must be insulated through the length of the horizontal run.

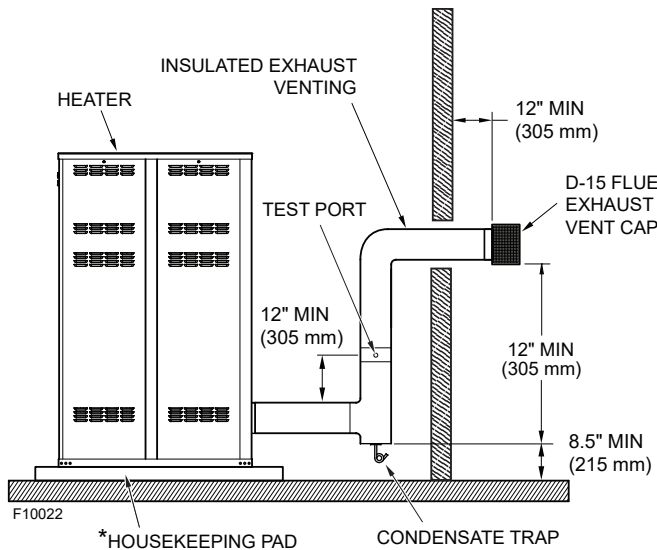

* See Figure 6 on page 8.

Figure 36. Horizontal Through-the-Wall Venting

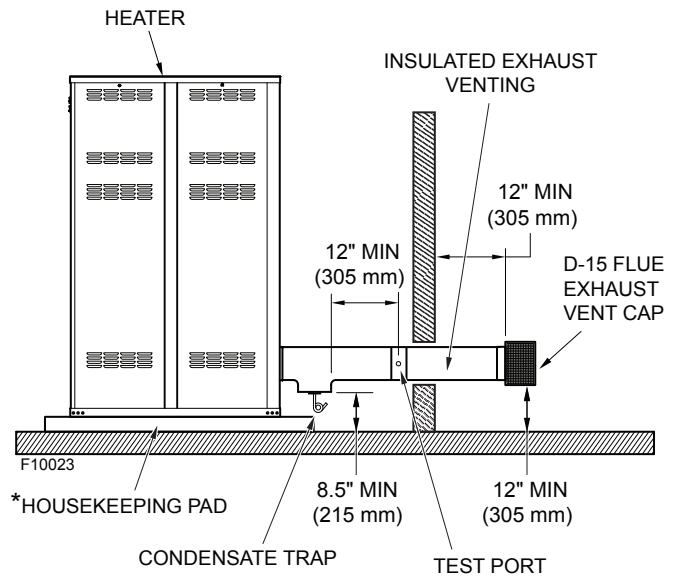

* See Figure 6 on page 8.

Figure 37. Alternate Horizontal Through-the-Wall Venting

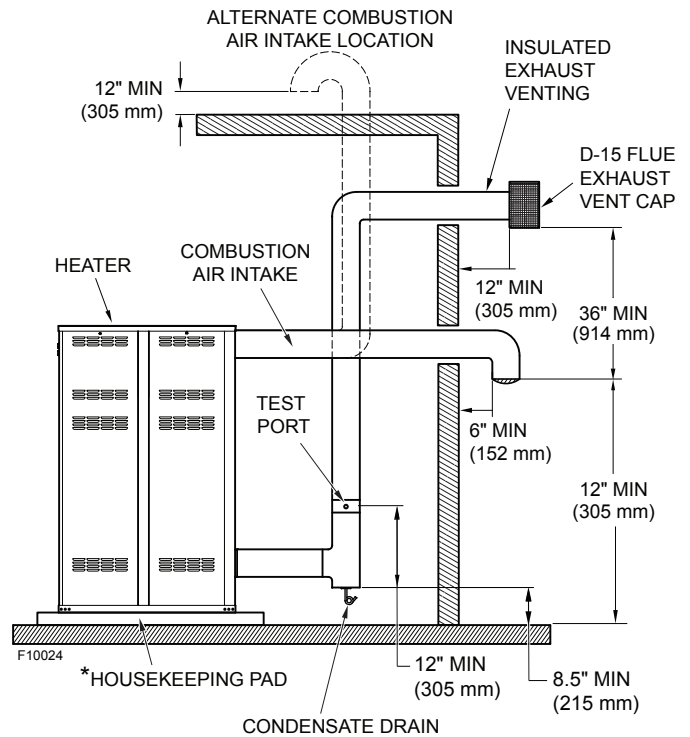

* See Figure 6 on page 8.

Figure 38. Horizontal Direct Venting

3.18.2. Termination

The Raypak sidewall vent termination (sales option D-15) **MUST** be used and **MUST** be mounted on the exterior of the building. The D-15 cannot be installed in a well or below grade. The D-15 must be installed at least 1' (305 mm) above ground level and above normal snow levels.

The Raypak approved horizontal, stainless steel flue direct vent cap **MUST** be used. The vent terminal must be located NO CLOSER than 12" (305 mm) off the wall.

⚠ WARNING: Mixing of different manufacturer's venting material is not permitted and this may create an unsafe condition.

3.19. Direct Vent - Vertical

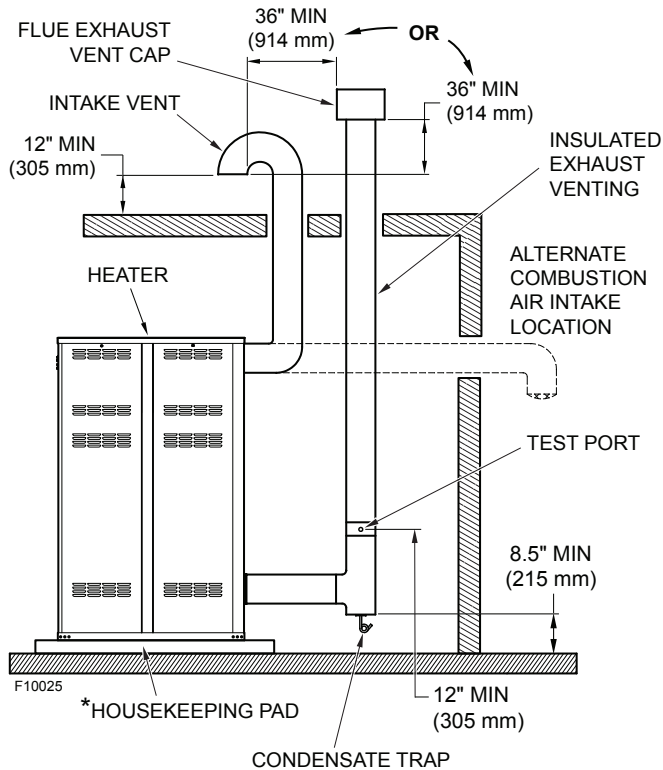

* See Figure 6 on page 8.

Figure 39. Direct Vent-Vertical

3.19.1. Installation

⚠ CAUTION: This venting system requires the installation of a condensate drain in the vent piping per the vent manufacturer's instructions. Failure to install a condensate drain in the venting system may cause a non-warrantable failure. Condensate is acidic and highly corrosive. Condensate must not be allowed to freeze. Take appropriate measures.

These installations utilize the heater-mounted blower to draw combustion air from outdoors and vent combustion products to the outdoors.

The total length of air supply pipe cannot exceed the distances listed in **Table P**. Each elbow used is equal to 10' (3 m) of straight pipe. This will allow installation in any arrangement that does not exceed the lengths shown in **Table P**. The vent cap is not considered in the overall length of the venting system.

Care must be taken during assembly that all joints are sealed properly and are airtight.

The vent must be installed to prevent the potential accumulation of condensate in the vent pipes. It is required that:

1. The vent must be installed with a condensate drain located in proximity to the heater as directed by the vent manufacturer.
2. The vent must be installed with a slight upward slope of not more than 1/4 inch per foot of horizontal run to the vent terminal.
3. The vent must be insulated through the length of the run.

3.19.2. Termination

The vent cap **MUST** be mounted on the exterior of the building. The vent cap cannot be installed in a well or below grade. The vent cap must be installed at least 1' (305 mm) above ground level and above normal snow levels.

The vent cap **MUST NOT** be installed with any combustion air inlet directly above a vent cap. This vertical spacing would allow the flue products from the vent cap to be pulled into the combustion air intake installed above.

This type of installation can cause non-warrantable problems with components and poor operation of the heater due to the recirculation of flue products. Multiple vent caps installed in the same horizontal plane must have a 4" (100 mm) clearance from the side of one vent cap to the side of the adjacent vent cap(s).

Combustion air supplied from outdoors must be free of particulate and chemical contaminants. To avoid a blocked flue condition, keep the vent cap clear of snow, ice, leaves, debris, etc.

⚠ WARNING: No substitutions of flue pipe or vent cap material are allowed. Such substitutions would jeopardize the safety and health of inhabitants.

3.20. Common Venting

Raypak does not support common venting of any product under positive vent pressure. Use a variable-speed extractor to draw the common stack to negative pressure (cat II) as shown in **Figure 40**.

3.21. Outdoor Installation

XTherm heaters are certified for outdoor operation in non-freezing conditions only. Freezing conditions may cause condensate to freeze in the condensate drain line and trap, causing the unit to shut down from a blocked condensate drain. Take appropriate measures. Additionally, components of the condensate management system may be damaged by the ice formation. Units installed in freezing climates for seasonal use must be winterized to avoid freeze damage to the heater.

Outdoor models must be vented with listed vent material per the following instructions and installed with the optional factory-supplied outdoor vent kit. A special vent cap is provided in accordance with CSA requirements. It must be installed directly on the vent pipe as illustrated in **Figure 41**.

Care must be taken when locating the heater outdoors, because the flue gases discharged from the vent cap can condense as they leave the cap. Improper location can result in damage to adjacent structures or building finish. For maximum efficiency and safety, the following precautions must be observed:

1. Outdoor models must be installed outdoors and must use the outdoor vent cap available from the manufacturer (sales order option D-11).
2. Periodically check venting system. The heater's venting areas must never be obstructed in any way and minimum clearances must be observed to prevent restriction of combustion and ventilation air. Keep area clear and free of combustible and flammable materials.
3. Do not locate adjacent to any window, door, walkway, or gravity air intake. The vent must be located a minimum of 4' (1.2 m) horizontally from such areas.
4. Install above grade level and above normal snow levels.
5. Vent terminal must be at least 3' (1 m) above any forced air inlet located within 10' (3 m).
6. Adjacent brick or masonry surfaces must be protected with a rust-resistant sheet-metal plate.

NOTE: The vent cap must be furnished by the heater manufacturer in accordance with its listing (sales order option D-11).

NOTE: Condensate can freeze on the vent cap. Frozen condensate on the vent cap can result in a blocked flue condition and non-warrantable failure. Condensate is acidic and highly corrosive. Condensate must not be allowed to freeze. Take appropriate measures.

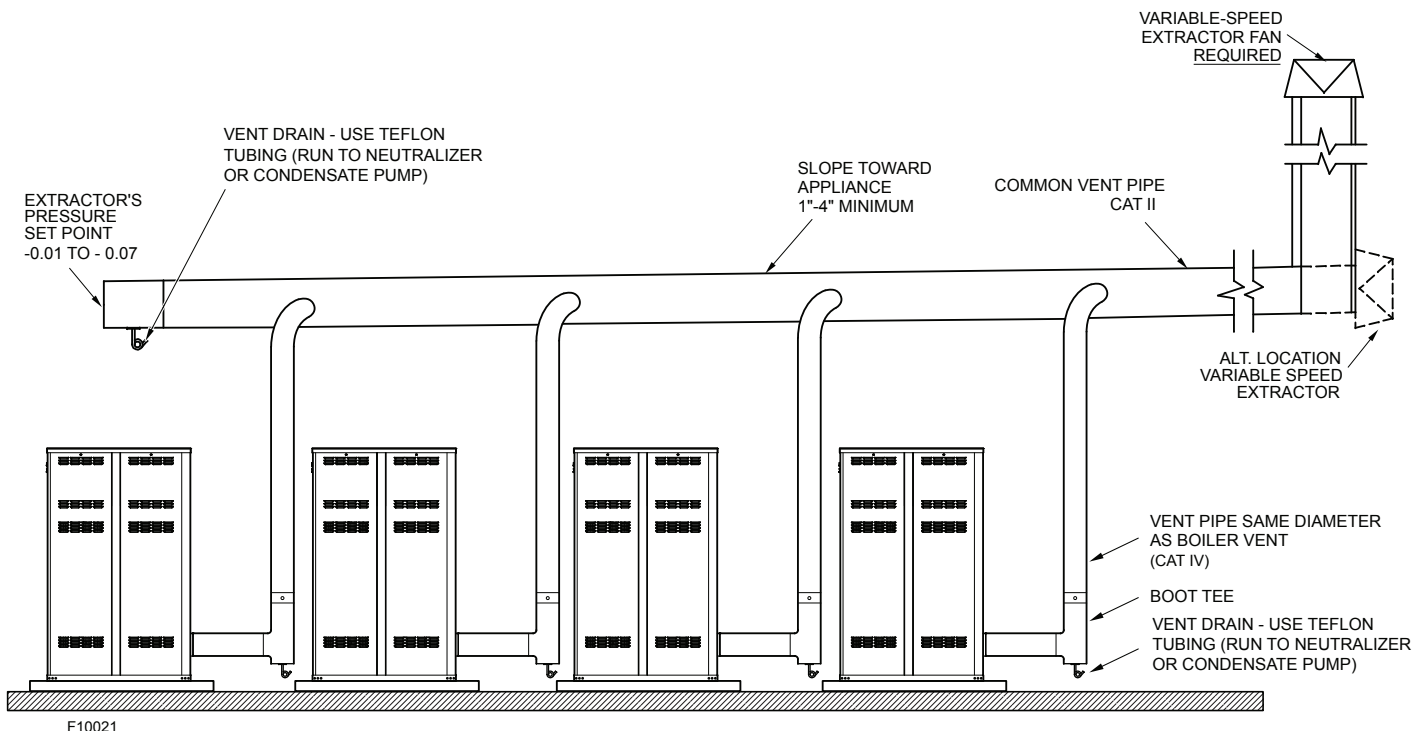

Figure 40. Typical Common Venting Installation

3.21.1. Freeze Protection

To enable freeze protection, DIP switch position 7 (on the PIM) must be turned on (UP position). This is the default position.

If the water temperature drops below 45°F (7°C) on the Outlet or Inlet sensors, the Boiler pump is enabled. The pump is turned off when both the Inlet and Outlet temperatures rise above 50°F (10°C).

If either the outlet or inlet temperature drops below 38°F (3°C), the VERSA starts the burner at the minimum firing rate. The burner cycle will terminate when both the Inlet and Outlet temperatures rise above 42°F (6°C).

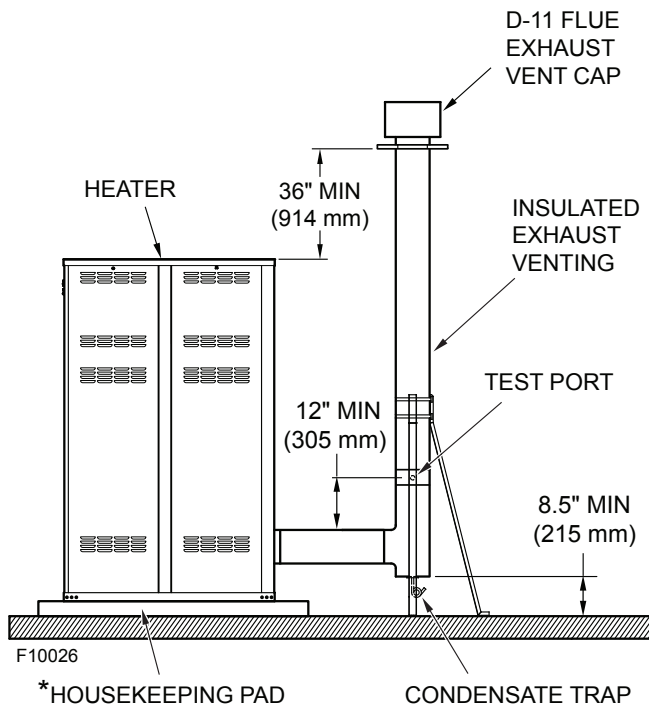

* See Figure 6 on page 8.

Figure 41. Outdoor Installation

3.22. Condensate Treatment

The condensate must be drained properly to protect the appliance and drainage system. The condensate from the heater is acidic. Its pH is typically between 3.2 and 4.5. Raypak recommends treating the condensate with a Condensate Treatment kit (Sales order option Z-12). The Treatment kit is connected to the condensate drain system and contains treatment media to raise the pH level of the condensate. The kit should be added to avoid damage to the drainage system and to meet local code requirements. The pH of the effluent entering a sanitary drain must be 5.0 or higher.

Vent pipe condensate drains are also required for installation of the XTherm. Follow vent manufacturer instructions for location of condensate drains in the vent. The vent condensate should also be routed through a treatment kit, as required by local code. See **Figure 43**.

The treatment kit must be sized to the amount of condensate generated by the appliance and the vent.

CAUTION: In general, the condensate piping from the appliance must have a downward slope of ¼" per horizontal foot. Condensate drain traps must be primed with water to prevent gas flue leaks. Treatment kits should be checked at least once per year. To ensure the pH of the effluent is 5.0 or higher, the media should be replenished as necessary. When replacing the media, they should be no smaller than ¾" to avoid blockage in the condensate piping. Figure 43 is a visual guide only. Follow the manufacturer's instructions for the installation of the Treatment kit and condensate drains.

WARNING: Do not install the heater outdoors if freezing conditions are typical. The condensate will freeze and back up the flue system.

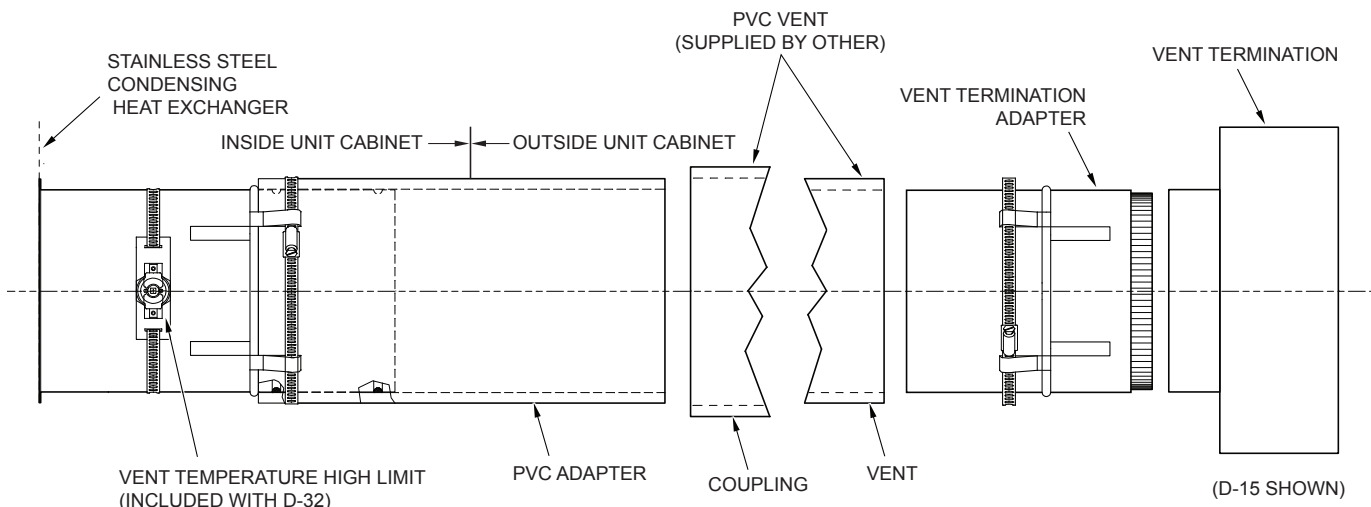

Figure 42. D-32 PVC Vent Adapter

3.23. PVC Venting Option (D-32)

Venting of the XTherm with PVC material requires the factory-installed D-32 adapter kit as well as a manual reset high limit with max setting 200°F (93°C). The PVC vent adapter is shown in **Figure 42**. This option is not available for field installation.

CAUTION: The inlet water temperature to the XTherm must not exceed 170°F (77°C) at any firing rate to use the PVC venting option. The venting system must conform to local codes and/or the current National Fuel Gas Code ANSI Z223.1/NFPA 54. The system setpoint must not exceed 180°F (82°C).

Cleaning

Prior to installing the PVC pipe and fittings, ensure that all burrs and/or ridges have been removed. Failure to remove burrs or ridges will result in the cement in the fitting socket being scraped from the socket surface, producing a dry joint with a high probability of joint failure. Remove all burrs with a knife, or with abrasive paper.

Surfaces to be joined must be cleaned and be free of dirt, moisture, oil, and other foreign materials.

DANGER: Primer, cleaner, and cements are extremely flammable. They are harmful or fatal if swallowed. The vapors are harmful. They may irritate eyes and skin and can be absorbed through the skin. Read and observe all safety information printed on primer, cleaner, and cement containers.

Termination

Termination should be accomplished using the adapter thimble as shown. The adapter thimble is supplied by Raypak as part of the D-32 option.

PVC vent assembly instructions

1. Cut pipe ends squarely, removing all burrs and dirt.
2. Dry fit pipe and fittings to be connected for proper fit.
3. Clean pipe and fitting with a cleaner.
4. Apply a coat of primer to pipe and fitting.
5. Apply a thin coat of cement to fitting, avoiding puddling inside.
6. Apply a liberal coat of cement to pipe leaving no voids.
7. QUICKLY assemble parts while cement is fluid! If you wait too long, re-coat pipes.
8. Push pipe completely into socket of fitting, rotating 1/4 turn to achieve proper orientation until it bottoms out.
9. Hold pipe and fitting together for 30 seconds, then carefully clean off excess with a cloth. The glue bonds by melting the PVC and they will re-harden during curing.

PRECAUTIONS: Always store primers, cleaner, and cements in cool, dry, well ventilated places. Do not store them near heat, sparks, or flames. Keep containers closed. Use them in well ventilated areas. Wear impervious clothing while handling. Do not smoke, eat, or drink while handling. Wash thoroughly after handling and before eating. Wear eye protection when handling. If swallowed, drink water, do not induce vomiting, and call a physician or poison control center immediately. If inhaled, get fresh air and seek medical attention if ill feelings persist. In case of eye and/or skin contact, immediately flush with plenty of water for 15 minutes and seek medical attention if irritation persists.

All Primers, cleaners, and cements must meet all local codes.

- Before using primers, cleaners, and cements, stir or shake, making sure contents are liquid. Do not use if found to be lumpy or jelly-like.
- Restoration of the original viscosity or removal of gelation by adding solvents or thinners is not recommended.
- Primers and/or cement should be NSF and/or UPC listed.

NOTE: Cleaners and primers are intended for different functions and should not be considered interchangeable. Verify with vent material manufacturer for specific requirements.

DO NOT insulate PVC or CPVC vent pipe.

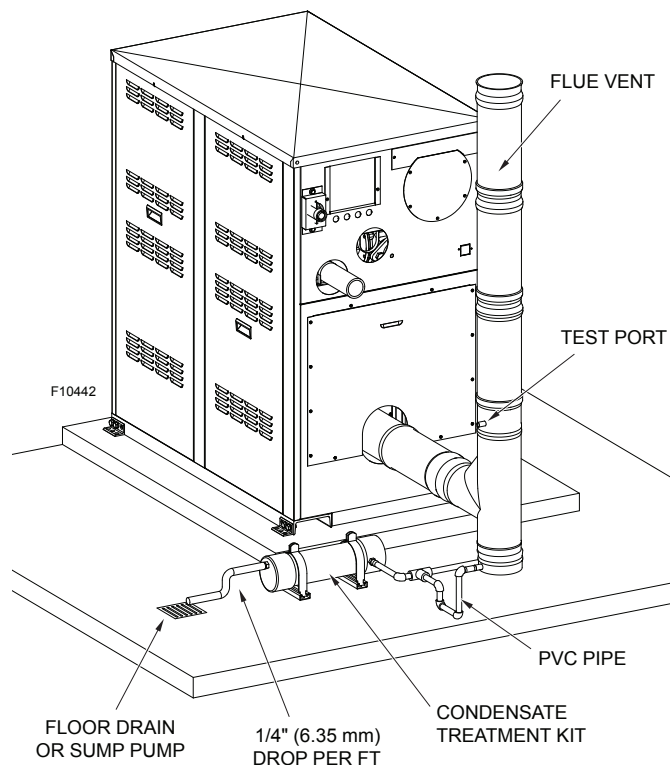

Figure 43. Visual Guide for Condensate Piping

10. Allow connections a sufficient time to cure before disturbing (follow manufacturer instructions).
11. For sidewall installations, a special vent adapter/termination (sales option D-15) must be used as supplied by Raypak per our listing.
12. Rooftop installations must use a Category IV listed vent cap.

3.24. Centrotherm™ Polypropylene Venting Option (D-33)

⚠ WARNING: Vent pipes must be adequately and securely supported; the vent weight must not be supported by the heater; this may cause unwarrantable damage.

Venting of the XTherm with polypropylene vent material requires the D-33 adapter kit available from Raypak.

The polypropylene vent adapter should appear as in **Figure 44**. The standard high limits [up to 240°F (116°C) for boilers, 200°F (93°C) for water heaters, 180°F (82°C) for pool heaters] may be used.

⚠ CAUTION: The inlet water temperature to the XTherm must not exceed 190°F at 100% fire to use the polypropylene venting option. The venting system must conform to local codes and/or the current edition of the National Fuel Gas Code ANSI Z223.1/NFPA 54.

Cleaning

Prior to installing Polypropylene pipe and fittings, ensure that all gaskets are free of grease, oil, debris or damage.

Installation

Vent pipes are joined by push-fit connections, with EPDM gaskets located in the sockets. Pipes and components must be installed with the socket ends to the outlet and male ends towards the appliance.

It is not recommended to install polypropylene when the material temperature is below 32°F (0°C).

Joining

Lubricate gaskets and male ends of pipes with CENTROCERIN™ lubricant or water only. Push male ends of pipes into gasketed openings with a light twisting motion.

Cutting

Components should be selected to minimize cutting. Where it is necessary, pipe sections may be cut to length at male ends (non-socketed end) only. Any cuts must be made at right angles to the pipe. Pipe must then be beveled for insertion into the adjoining socket to ease installation. All field cuts must be deburred. Bends and other preformed components must not be cut.

Termination

Termination should be accomplished using the adapter as shown in **Figure 44**.

Polypropylene Construction

- ULC-S636 Certified, making it approved for use in Canada
- Zero Clearance to Combustibles

Storage

Components should be stored in a clean, dry environment in their original packaging. Non-UV stabilized plastic components must be protected from prolonged exposure to UV light.

Appliance Start-Up

Once polypropylene installation is complete, the heating system and flue should be commissioned following Raypak's instructions. There is no cure time or wait time required.

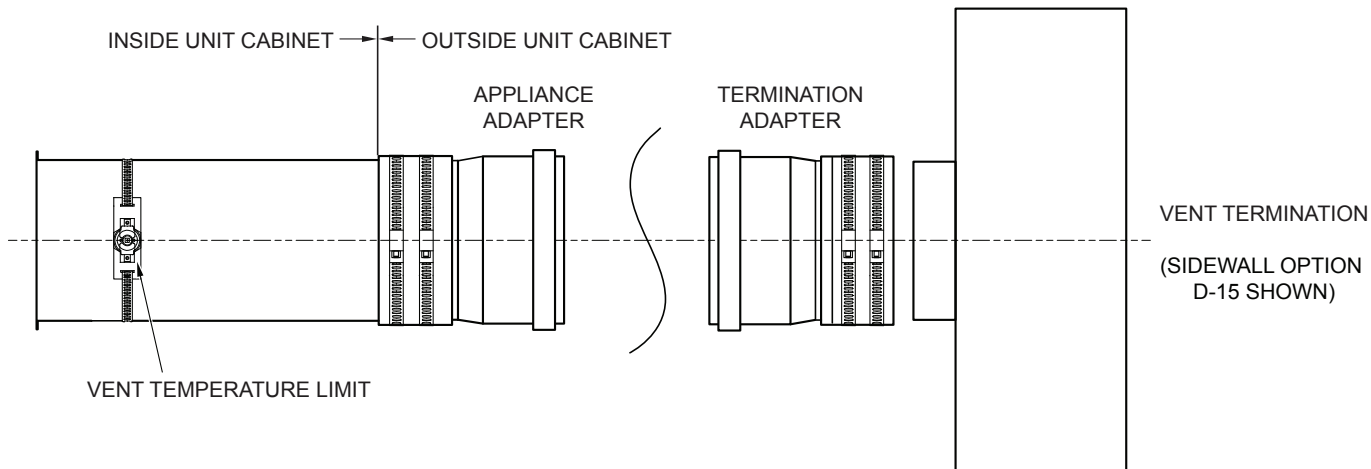

Figure 44. D-33 Centrotherm Polypropylene Vent Adapter

4. CONTROLS

▲ WARNING: Installation, adjustment and service of heater controls, including timing of various operating functions, must be performed by a qualified installer, service agency or the gas supplier. Failure to do so may result in control damage, heater malfunction, property damage, personal injury, or death.

▲ WARNING: Turn off the power to the heater before installation, adjustment or service of any heater controls. Failure to do so may result in board damage, heater malfunction, property damage, personal injury, or death.

▲ CAUTION: This appliance has provisions to be connected to more than one supply source. To reduce the risk of electric shock, disconnect all such connections before servicing.

▲ CAUTION: Risk of electric shock: More than one disconnect switch may be required to de-energize the equipment before servicing.

4.1. Ignition Control Functions

When there is a call for heat, and all safeties are closed and minimum flow rate detected, then the combustion air blower starts to purge air from the combustion chamber. After the pre-purge, the igniter is energized. The standard ignition module will lock-out after failing to light 3 times during a call for heat. To reset the lock-out, press and release the RESET button located adjacent the user interface. The control will automatically reset after 1 hour. When in lock-out the control will run the blower through a post-purge cycle.

The single-try ignition module (part of the CSD-1 option) will attempt to light only one time before lock-out occurs. To reset the lock-out, press and release the RESET button located adjacent the user interface.

Turning off the power to the heater WILL NOT reset the single-try ignition module.

NOTE: Ignition modules are common for all XTherm model sizes. However, model-specific operating parameters are defined by their respective ID cards.

4.2. High Limit - Manual Reset

This heater is equipped with a fixed-setting manual reset high limit temperature device as standard. It may also have an additional optional adjustable manual reset high limit temperature device.

The optional manual reset high limit is located inside the cabinet on the upper right corner post. See **Figure 2**.

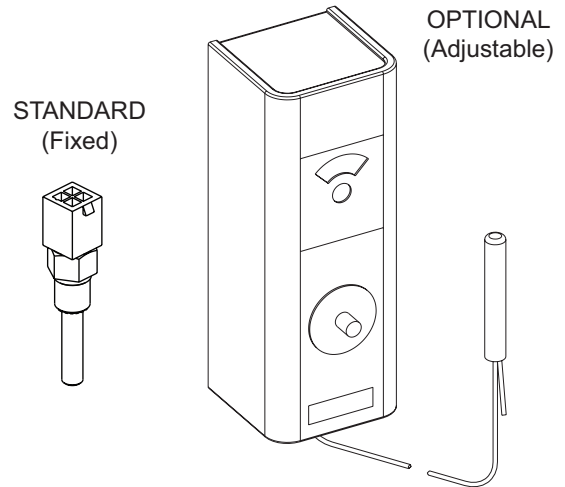

Figure 45. High Limit (Manual Reset)

The fixed-setting manual reset high limit is built into the PIM, and utilizes a dual-element sensor located on the outlet. See **Figure 2**.

H	240°F (116°C)
WH	200°F (93°C)
P	180°F (82°C)

To reset a high limit lock-out, press and release the RESET button located adjacent the user interface.

4.3. High Limit - Auto Reset (Optional)

This heater may be equipped with an optional adjustable auto-reset high limit temperature device.

The optional adjustable auto reset high limit is located inside the cabinet on the upper right corner post. See **Figure 2**. Adjust the setting to approx. 20°F (11°C) above desired outlet temperature.

4.4. Variable-Speed Injector Pump

Some XTherm models are equipped with dual variable-speed injector pumps, like the one shown below. **Figure 46** shows the DIP switch settings, setpoint (MIX Target) and factory wiring.

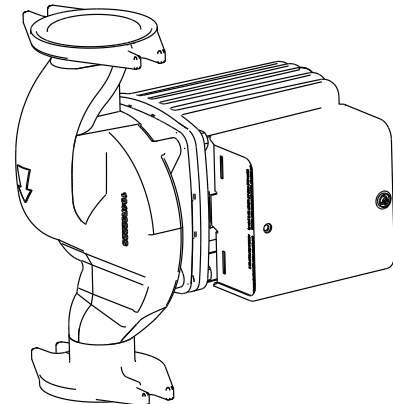

Figure 46. Variable-Speed Injector Pump

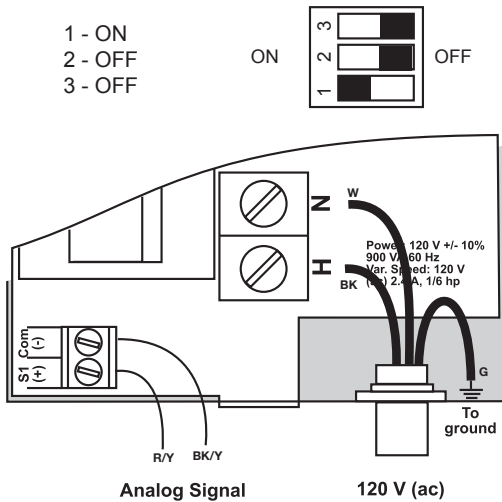

Figure 47. Injector Pump DIP Switches, and Wiring

4.5. Condensate Float Switch

This heater is equipped with a condensate float switch to prevent operation when the condensate water level is too high. The heater shutting down from the condensate float switch is indicative of a blocked drain or problem with the condensate management system. The condensate float switch is located inside the vent outlet plenum at the left rear of the heater.

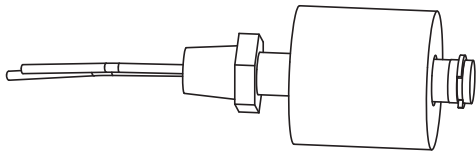

Figure 48. Condensate Float Switch

4.6. Flow Switch

This standard, dual-purpose control shuts off the heater in case of pump failure or low water flow through the primary loop.

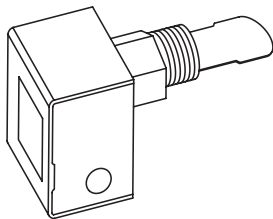

Figure 49. Flow Switch

NOTE: The wiring diagrams in this manual show all standard options. Refer to the large wiring diagram provided with your heater for options installed on your specific unit(s).

4.7. Low Water Cut-Off (Optional)

The optional low water cut-off (sales option F-10) automatically shuts down the burner whenever the

water level drops below the level of the sensing probe. A 5-second time delay prevents premature lockout due to temporary conditions such as power fluctuations or air pockets.

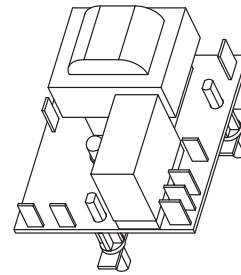

Figure 50. Low Water Cut-Off Board

4.8. High and Low Gas Pressure Switches (Optional)

The low gas pressure switch (sales option S-1) mounts upstream of the gas valve (on the inlet flange to the gas valve) and is accessible through the removable access panels on the side or front of the heater to reset the gas pressure switch, as necessary. It is used to ensure that sufficient gas pressure is present for proper valve/regulator performance. The low gas pressure switch automatically shuts down the heater if gas supply drops below the factory setting of 3" WC for natural gas or propane gas.

The high gas pressure switch (sales option S-2) connection mounts down-stream of the gas valve and automatically shuts down the heater if the gas pressure to the burner rises above 3" WC for nat or pro. Special ports are located on the backside of the gas valve and accessible from the front of the heater (to reset the gas pressure switch) or through the removable access panels on the rear of the heater (to reset the gas pressure switch), as necessary. If the gas pressure regulator in the valve fails, the high gas pressure switch automatically shuts down the burner.

Operation of either the High or Low Gas Pressure Switch will turn on an LED inside the switch housing. Push the top of the plastic switch housing as shown in **Figure 51** to reset a tripped pressure switch. The LED will go out when the switch is reset.

These safety devices will emit small amounts of fuel gas, and must be piped to a safe discharge location outdoors, per local code requirements.

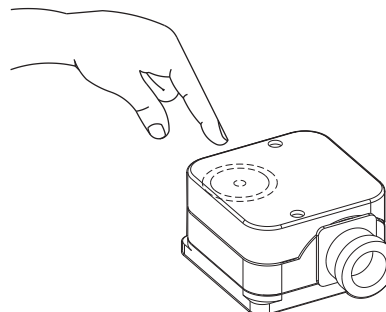

Figure 51. High/Low Gas Pressure Switch

4.9. Blocked Vent Switch

This heater is equipped with a blocked vent pressure switch to prevent the operation of the heater when too much of the vent is blocked. This switch is located on the right side of the heater near the right rear corner and activates at approximately 2" WC positive vent pressure.

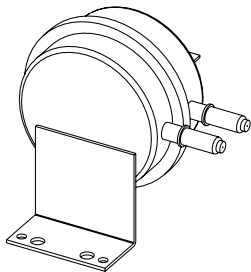

Figure 52. Blocked Vent Switch

4.10. User Interface

The touchscreen user interface uses a high definition 7" (178 mm) capacitive screen. It includes an extensive graphical library used to represent different pipe configurations, error location, and operation of the unit. The touchscreen has the same basic menu distribution as the original VERSA LCD Display, when pressing the MENU button the menu bar becomes visible at the bottom of the screen allowing navigation through four additional sub menus (VIEW, ADJUST, Heater, and TOOLS).

For detailed descriptions of the various screens, page flows and basic instructions, consult the Touchscreen quick start user guide (5000.74) and VERSA IC control manual (5000.72).

If your unit has Raymote installed, refer to the Raymote installation and operation manual (5000.721).

4.10.1. Adjusting the XTherm Setpoint

Use the MENU button to open the menu options, select the ADJUST menu, go to System Settings page. Once in

the system settings screen use the Setpoint item. Adjust the setpoint using the UP and DOWN arrow.

After making the setpoint selection press SET button to apply the changes (a confirmation bar will turn green showing that value has been applied). Minimum setpoint is 50°F (10°C); maximum is 220°F (104°C) for H models, 150°F (66°C) for WH models and 104°F (40°C) for P models. The default setpoint is 180°F (82°C) for H models, 125°F (52°C) for WH models and 80°F (27°C) for P models.

4.10.2. View Menu

The VIEW menu is the default menu. See **Table R**. It displays sensor temperatures, the modulation rate of the blower, heater cascade status, pump operation and CFH information. Some of the items displayed are mode specific and are only observable when its corresponding mode is active.

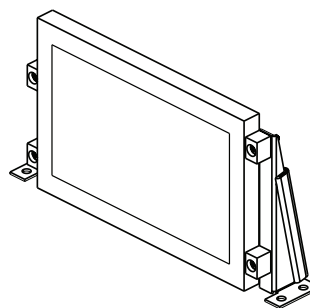

Figure 53. Use Interface

4.10.3. Menu - Initial Adjustment

To change settings on the touchscreen, press MENU icon, Adjust icon, System settings, System menu to open Adjust Settings menu. The ADJUST menu allows the installer to make adjustments to items shown in **Table S**.

Refer to the VERSA IC control manual (5000.72) for detailed setup instructions.

Item	Application	Description
OUTDOOR	H MODE 1, 2, 3	Outdoor air temperature, available when TARGET = RSET in ADJUST menu
Target	H MODE 1, 2, 3	Current target temperature, available when Target = SETP in the ADJUST menu (default), and (EMS / MODB)
SUPPLY	H MODE 1, 2, 3	Current system supply temperature
IND SUPPLY	H MODE 3	Current temperature being supplied to the indirect system
Boil OUTLET	All	Current heater outlet temperature
Boil INLET	All	Current heater inlet temperature
Boil ΔT	All	Current temperature difference between heater outlet and heater inlet
DHW SUPPLY	H MODE 2, 3	Current indirect DHW supply temperature
TANK DHW	WH	Current tank temperature
POOL	P	Current pool temperature
BOILER STATUS	All	IDLE, PREP, IGN, MOD RATE %, POST, SOFT, SOFT

Table R. View Menu

Item	Application	Range	Description	Default
TARGET	H MODE 1, 2, 3	RSET <> SETP	RSET = Outdoor Reset, SETP =Setpoint	SETP
TANK SETP	WH	OFF, 50°F to 150°F (10°C to 66°C)	Tank set point temperature	125°F (52°C)
TANK DIFF	WH	2°F to 10°F (1°C to 5°C)	Tank Differential temperature	3
POOL SETP	P	50°F to 104°F, 106°F (10°C to 41°C)	Pool setpoint temperature	80°F (27°C)
POOL DIFF	P	1°F to 5°F (0.5°C to 3°C)	Pool differential temperature	2°F (1°C)
MODE	H MODE 1, 2, 3	1,2,3	Piping and application configuration.	1
SETPOINT	H MODE 1, 2, 3	50°F to 220°F (10°C to 104°C)	Boiler target temperature while a heat demand is present for setpoint operation	180°F (82°C)
OUT START	H MODE 1, 2, 3	35°F to 85°F (2°C to 29°C)	Outdoor starting temperature - outdoor reset	70°F (21°C)
OUT DESIGN	H MODE 1, 2, 3	-60°F to 45°F (-51°C to 7°C)	Outdoor design temperature - outdoor reset	10°F (5°C)
Boil START	H MODE 1, 2, 3	35°F to 150°F (2°C to 66°C)	Starting boiler target temperature when the outdoor temperature is at outdoor start outdoor reset	70°F (21°C)
Boil DESIGN	H MODE 1, 2, 3	70°F to 200°F (21°C to 93°C)	Design boiler target temperature when the outdoor temperature is at outdoor design outdoor reset	180°F (82°C)
TARGET MAX	H MODE 1, 2, 3	100°F (38°C) to PIM value*	Maximum target system temperature	220°F (104°C)
TARGET MIN	H MODE 1, 2, 3	OFF, 50°F to 190°F (10°C to 88°C)	Minimum target system temperature	50°F (10°C)
TARGET DIFF	H MODE 1, 2, 3	2°F to 42°F (1°C to 24°C)	Differential for target system temperature	10°F (5°C)
IND SENSOR	H MODE 1, 2, 3	OFF <> ON	Selects whether a DHW sensor is used for indirect DHW tank	OFF
DHW DIFF	H MODE 2, 3	2°F to 10°F (1°C to 5°C)	Differential for the target indirect DHW tank temperature, requires IND Sensor = ON	6°F (4°C)
IND SUPPLY	H MODE 2, 3	OFF, 50°F (10°C) to PIM value*	Target boiler temperature for the DHW heat exchanger during indirect DHW operation, requires IND Sensor = OFF	180°F (82°C)
DHW PRIORITY	H MODE 2	OFF <> ON	Selects whether or not Indirect DHW priority is active during indirect DHW operation	OFF
PRI OVR	H MODE 2, 3	Au, 0:10hr to 2:00hr	Sets the length of the indirect DHW priority override time	1:00hr
SYS PURGE	All	OFF, 0:20min to 20:00min	Sets the length of the system pump post purge	20 seconds
MIX TYPE	H / WH / P MIX	H (VALVE, PUMP, PLNT) WH (1 <> 2)	Selects the type of control depending on pipe configuration for CWP	H VALVE WH 2
MIX TARGET	H / WH / P MIX	50°F to 104°F (10°C to 40°C)	Inlet target temperature	120°F (49°C)
MIX LOCK	H / WH / P MIX	ON <> OFF	The equipment will trigger a warning when "MIX Target" is not reached within 7 minutes. MIX LOCK = ON; Alarm and lockout, MIX LOCK = OFF; Alarm only	OFF
MIX TRIM	H / WH / P MIX	-5 to 5	This adjustment is for various types and sizes of units as well as various actuator motor speeds and types supplied by Raypak	0
MIX SPEED	H / WH / P MIX	FAST <> MED <> SLOW	This setting defines speed of response	MED
MIX INV	H / WH / P MIX	ON <> OFF	This option is related to the use of spring return actuators with a proportional valve	OFF
WWSD	H MODE 1,2,3	40°F to 100°F (4°C to 38°C)	The system warm weather shutdown temperature outdoor reset, requires TARGET = RSET	70°F (21°C)
UNITS	All	deg F <> deg C	Show units using icons in display	deg F
MODBUS	All	OFF <> MNTR <> TEMP <> RATE	ModBus Operating Mode: Off, Monitor, Temp Control, Rate Control	MNTR
ADDRESS	All	1 to 247	ModBus slave address	1
DATA TYPE	All	RTU <> ASCI	Modbus data type	RTU
BAUD RATE	All	2400 <> 9600 <> 19K2 <> 57K6 <> 115K		19K2
PARITY	All	NONE <> EVEN <> ODD		EVEN

* Maximum operator dial setting.

Table S. Setup/Adjust Menu

4.10.4. Boiler Menu

The Boiler View displays various items regarding ignition, temperature monitoring, and modulation rates. As well as software and hardware information

Item	Application	Description
BOILER 1	ALL	Enables Boiler for operation
BOILER 2	CASCADE	Enables Boiler for cascade operation
BOILER 3	CASCADE	Enables Boiler for cascade operation
BOILER 4	CASCADE	Enables Boiler for cascade operation
IGNITION	ALL	IDLE=no CFH; PREP=pre-purge or inter-purge between trials for ignition; IGN=trial for ignition; BURN=burner operating; POST=post purge; HARD=a hard lockout fault has occurred requiring manual reset (Ignition Lockout or manual high limit); and SOFT=a soft lockout fault has occurred which interrupts the heating cycle (any safety other than ignition or manual high limit). The CFH will resume after the soft lockout fault has been corrected and a 15 min. waiting period has expired.
VENT WALL	ALL	Monitors vent temperature and adjust firing rate if vent temperature approaches limit for vent material installed/selected.
LIMIT TEMP	ALL	Current Outlet-Limit temperature
EMS Vdc	ALL	Current EMS signal in Volts DC
FIRE RATE	ALL	PIM firing rate
SPEED	ALL	Blower speed in revolutions per minute (rpm)
OUTLET MAX	H Mode 1, 2, 3	Defines Max Outlet temperature offset above Target Setpoint (Press and hold up and down arrows for 3 seconds to enable adjustment). See VERSA IC control manual (5000.72).
OPERATOR	ALL	Operator Potentiometer setting on PIM
DIFF	ALL	Current auto differential – Fixed by PIM
Pump Post	ALL	Sets the length of the boiler pump purge
FLAME CUR	ALL	Flame current in micro-amps (μ A)
MASS	ALL	Thermal mass recovery see VERSA IC control manual (5000.72).
IDENTITY	ALL	Identifies the unit as boiler, water heater or pool heater
IGN TYPE	ALL	PIM Board type
ID CARD	ALL	Identifies Raypak Identity Card
ERROR CODE	ALL	Current Error Code
ERROR HISTORY	ALL	Up to 15 Error Codes can be logged

Table T. Boiler Menu

4.10.5. Monitor Menu

The Monitor Menu records and displays critical Heater information, such as Cycle times, Run times, and Maximum/Minimum temperature readings depending on the setup.

Item	Application	Description
RUN TIME Burner 1	All	Burner run time (hours). Press UP/DOWN for 1 sec to clear.
Cycles Burner	All	Number of burner cycles. Press UP/DOWN for 1 sec to clear.
RUN TIME Boiler pump	All	Boiler pump run time (hours). Press UP/DOWN for 1 sec to clear.
RUN TIME System pump	All	System pump run time (hours). Press UP/DOWN for 1 sec to clear.
RUN TIME DHW pump	H MODE 2, 3	DHW pump run time (hours). Press UP/DOWN for 1 sec to clear.
OUTLET HI	All	Records the highest boiler outlet temperature. Press UP/DOWN for 1 sec to clear.
OUTLET LO	All	Records the lowest boiler outlet temperature. Press UP/DOWN for 1 sec to clear.
INLET HI	All	Records the highest boiler inlet temperature. Press UP/DOWN for 1 sec to clear.
INLET LO	All	Records the lowest boiler outlet temperature. Press UP/DOWN for 1 sec to clear.
DELTA T	All	Captures the highest Delta T Temperature recorded. Press UP & DOWN buttons for 3 sec to clear this entry
OUTDOOR HI	H MODE 1, 2, 3	Records the highest outdoor temperature. Press UP/DOWN for 1 sec to clear.
OUTDOOR LO	H MODE 1, 2, 3	Records the lowest outdoor temperature. Press UP/DOWN for 1 sec to clear.
SYSTEM HI	All	Records the highest supply temperature. Press UP/DOWN for 1 sec to clear.
SYSTEM LO	All	Records the lowest supply temperature. Press UP/DOWN for 1 sec to clear.
IND HI	H MODE 1, 2, 3	Records the highest Indirect supply temperature. Press UP/DOWN for 1 sec to clear.
IND LO	H MODE 1, 2, 3	Records the lowest Indirect supply temperature. Press UP/DOWN for 1 sec to clear.
TANK HI	WH	Records the highest TANK temperature. Press UP/DOWN for 1 sec to clear.
TANK LO	WH	Records the lowest TANK temperature. Press UP/DOWN for 1 sec to clear.
POOL HI	P	Records the highest POOL temperature. Press UP/DOWN for 1 sec to clear.
POOL LO	P	Records the lowest POOL temperature. Press UP/DOWN for 1 sec to clear.

Table U. Monitor Menu

4.10.6. Toolbox Menu

The Toolbox Menu logs all error codes from the VERSA and PIM, as well as other functions.

Item	Description
Lookup Active Error	Look up and display the active error info.
USER TEST	Select ON to start the function. The setting returns to default after the test is run.
MAX HEAT	Select ON to start the function. The setting will time out to OFF after 24 hours or can be set to OFF again by the user. See VERSA IC control manual (5000.72) for details.
P/N 104901	Software number of the Raypak VERSA.
DEFAULTS	Resets to factory settings. Press UP and DOWN for 1 second to show CLR and load factory defaults to all settings. This will also clear all history.
HISTORY <i>lookup logged error</i>	Displayed when an error code is present. 1 indicates the most recent error code. Press UP and DOWN for 1 second to clear the error logs.

Table V. Toolbox Menu

4.10.7. Outdoor Reset Concept

The Temperature controller can change the System Setpoint based on outdoor temperature (Outdoor Reset). The temperature controller varies the temperature of the circulating heating water in response to changes in the outdoor temperature. The heating water temperature is controlled through the modulation and/or sequencing of the cascade.

The Temperature controller can also control the system circulating pump with an adjustable Outdoor Cutoff. When the outdoor temperature is above the Outdoor Cutoff, the pump is turned off and no heating water is circulated through the system. When the outdoor temperature drops below the Outdoor Cutoff, the system pump relay is activated and the heating water circulates through the system. The temperature of the heating water is controlled by the Reset Ratio, Water Offset, and changes with the outdoor temperature.

Reset Ratio/Outdoor Reset

When a building is being heated, heat escapes through the walls, doors, and windows to the colder outside air. The colder the outside temperature, the more heat escapes. If you can input heat into the building at the same rate that it is lost out of the building, then the building temperatures will remain constant. The Reset Ratio is an adjustment that lets you achieve this equilibrium between heat input and heat loss. See **Figure 54**.

The starting point for most systems is the 1.00 (OD):1.00 (SYS) (Outdoor Temperature: Heating Water Temperature) ratio. This means that for every degree the outdoor temperature drops, the temperature of the heating water will increase one degree. With the VERSA, both ends of

the slope are adjustable. It is factory set at 70°F (21°C) water temperature (Boil START) at 70°F (21°C) outdoor air (OUT START), and 180°F (82°C) water temperature (Boil DESIGN) at 10°F (-12°C) outdoor air (OUT DESIGN).

Each building has different heat loss characteristics. A very well insulated building will not lose much heat to the outside air, and may need a Reset Ratio of 2.00 (OD):1.00 (SYS) (Outdoor: Water). This means the outdoor temperature would have to drop 2 degrees to increase the water temperature 1 degree. On the other hand, a poorly insulated building may need a Reset Ratio of 1.00 (OD):2.00 (SYS). This means that for each degree the outdoor temperature dropped the water temperature will increase 2 degrees. The VERSA control Reset Ratio allows for full customization to match any buildings heat loss characteristics.

A heating curve that relies not only on Outdoor temperature but also on the type of radiation will improve heat comfort. The user can fine tune these adjustments based on the specific building need.

Reset Ratio Settings

The controller uses the four following settings to determine the reset ratio:

1. Heater Start (**Boil START**)

The Boil START temperature is the theoretical heater supply water temperature that the heating system requires when the outdoor air temperature equals the OUT START temperature setting. The Boil START is typically set to the desired building temperature.

2. Outdoor Start (**OUT START**)

The OUT START temperature is the outdoor temperature at which the control provides the Boil START water temperature to the system. The OUT START is typically set to the desired building temperature.

3. Outdoor Design (**OUT DESIGN**)

The OUT START is the outdoor temperature that is typical coldest annual temperature where the building is located. This temperature is used when completing heat loss calculation for the building.

4. Heater Design (**Boil DESIGN**)

The Boil DESIGN temperature is the water temperature required to heat the heater zones when the outdoor air is as cold as the OUT DESIGN temperature.

Warm Weather Shut Down (WWSD)

When the outdoor air temperature rises above the WWSD setting, the control turns on the WWSD segment in the display. When the control is in the Warm Weather Shut Down, the Dem 1 segment is displayed if there is a heat demand. However, the control does not operate the heater to satisfy this demand. The control continues to respond to DHW demands.

Reset Ratio

The controller uses the following four settings to calculate the Reset Ratio (RR):

For example, when using the default values, the RR is:

$$\text{RESET RATIO} = \frac{(\text{OUTDOOR START} - \text{OUTDOOR DESIGN})}{(\text{BOILER DESIGN} - \text{BOILER START})}$$

$$\text{RR} = (70 - 10) / (180 - 70) = 0.55$$

Therefore, the RR is 0.55:1 (Outdoor : Water).

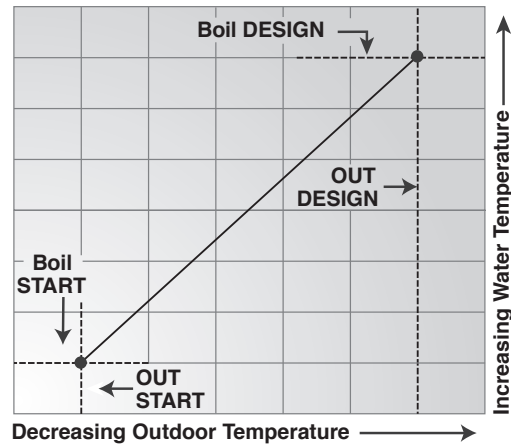

Figure 54. Reset Ratio

NOTE: The wiring diagrams in this manual show all standard options. Refer to the large wiring diagram provided with your heater for options installed on your specific unit(s).

6. START-UP

NOTE: The following steps must be performed by a factory-trained technician.

6.1. Pre Start-up

6.1.1. Filling System (Heating Boilers)

Fill system with water. Purge all air from the system. Lower system pressure. Open valves for normal system operation, and fill system through feed pressure. Manually open air vent on the compression tank until water appears, then close vent.

6.1.2. Air Purge

Purge all air from system before heater operation. This can normally be accomplished by opening a down-stream valve.

▲ CAUTION: An air vent valve should be field-installed at the highest point in the system for proper operation.

6.1.3. Venting System Inspection

1. Check all vent pipe connections and flue pipe material.
2. Make sure vent terminations are installed per code and are clear of all debris or blockage.
3. Ensure vent material has been inputted into VERSA control.

6.1.4. Lighting Instructions/Warnings

For Your Safety

This appliance has a hot surface igniter. It is equipped with an ignition device which automatically lights the burners. Do not try to light the burners by hand.

▲ WARNING: If you do not follow these instructions exactly, a fire or explosion may result causing property damage, personal injury or loss of life.

BEFORE OPERATING, smell all around the appliance area for gas. Be sure to smell near the floor because some gas is heavier than air and will settle on the floor.

WHAT TO DO IF YOU SMELL GAS:

- Do not try to light any appliance.
- Do not touch any electrical switch; do not use any telephone in your building.
- Immediately call your gas supplier from a neighbor's telephone. Follow the gas supplier's instructions.
- If you cannot reach your gas supplier, call the fire department.
- Use only your hand to turn the gas control valve

handle. Never use tools. If the handle will not turn by hand, do not try to repair it; call a qualified service technician. Forced or attempted repair may result in a fire or explosion.

- Do not use this appliance if any part has been under water, immediately call a qualified service technician to inspect the appliance and to replace any part of the control system and any gas control which has been under water.
- Check around unit for debris and remove combustible products, i.e. gasoline, etc.

6.2. Pre Start-up Check

1. Verify the heater is filled with water.
2. Check system piping for leaks. If found, repair immediately.
3. Vent air from system. Air in system can interfere with water circulation.
4. Purge air from gas line to heater.

6.3. Initial Start-up

6.3.1. Required tools

- (1) 12-0-12 (24" scale) U-tube manometer
- (2) 6-0-6 (12" scale) U-tube manometer
- Screwdrivers (assorted sizes and shapes)
- (1) Crescent wrench (8" or 10")
- (1) Multi-meter
- (1) Flue gas analyzer

(Metric Allen wrenches will be required for servicing the gas valve, but not during start-up)

6.4. Preparation

6.4.1. Check Power Supply

With multi-meter at incoming power, check voltage between:

Hot - Common (≈ 120 VAC)

Hot - Ground (≈ 120 VAC)

Common - Ground (< 1 VAC)

6.4.2. Attach Manometers to Measure Pressures

NOTE: Digital manometers are not recommended.

1. Turn off main gas valve.
2. Attach (1) 12" scale manometer to an upstream bleedle valve on the gas supply pipe to the heater (Measure point "A" in **Figure 55**).

- Attach (1) 24" scale manometer to the manifold pressure tap located near the shutoff valve downstream of the firing valve (Measure point "C" in **Figure 55**).
- Attach (1) 12" scale manometer on the fan suction pressure hose. Pull black cap from the air pressure tee as shown in **Figure 55** and connect the manometer.

NOTE: Retain caps for reinstallation later.

6.4.3. Check Gas Supply Pressure

- Slowly turn on main gas shut-off valve.

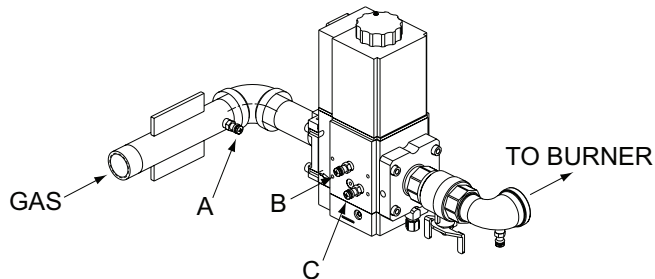

Figure 55. Gas Pressure Measurement Locations

- Read the gas supply pressure from the manometer; minimum supply pressure for natural gas is 4" WC, recommended supply is 7" WC, minimum supply pressure for propane gas is 4" WC, recommended supply is 11" WC (dynamic readings, full fire input).
- If the gas pressure is greater than 14" WC, turn off the main gas shut-off valve, upstream of the heater.

6.5. Start-Up

NOTE: The values in Table W represent the conditions when the heater is at full firing rate at sea level.

NOTE: Pressure and combustion data are provided with the heater.

- Turn power on.
- Turn on the heater, switch Enable/Disable rocker switch to top position to enable CFH wait approximately 15 seconds after the blower starts, the igniter should start to glow (observable through the observation port located on top of the combustion chamber. Gas valve should open in 45-60 seconds.
- The heater ignites at 30% to 40% of full rate (as indicated on the touch screen display of the temperature controller located behind the front panel).
- If the burner fails to light on the first 4-second trial for ignition, it will try for ignition up to three times before going into lockout with the standard ignition module. If the heater is equipped with the optional single-try ignition module, it will go into lockout.

- Wait until the controller indicates 100% on the firing rate display screen (approximately 30 seconds).

6.5.1. Blower Check

- Check blower suction using the manometer attached to the air pressure tee, with the heater firing at 100% input. The reading should be as noted in **Table W** for both natural and propane gas.

NOTE: Retain the black plastic cap removed to install the manometer. It needs to be replaced when the manometer is removed.

- When firing at 100%, the desired heater combustion CO₂ is 9.0% ± 0.4% for natural gas and 10.3% ± 0.4% for propane with CO less than 100 ppm. If this combustion cannot be achieved with the blower suction within the tolerances specified in **Table W**, contact the factory.
- For Models H and WH only:** CO₂ and CO levels must be checked at minimum fire. When firing at minimum fire, the desired combustion CO₂ is 9.0% for natural gas and 10.3% for propane gas with CO less than 100 pm. If CO₂ is not between 7.5% and 9.5% for natural gas, or between 8.0% and 10.5% for propane gas; and if CO is above 100 ppm in either case, stop running the unit and contact your Raypak representative. Visit www.raypak.com for contact information.

NOTE: Technician performing initial start-up must carry a calibrated combustion analyzer to ensure desired combustion levels are achieved.

⚠ WARNING: The unit has been factory tested and per-certified at the reference gas pressure as shown on the unit decal. If the desired CO₂ and CO values are not achieved at the listed air pressure in Table T within the tolerance specified, contact your local Raypak Representative or Raypak Factory for direction. Do not alter the settings of installed components. Tampering with preset values can lead to poor performance of the unit and result in personal injury, death or property damage.

⚠ WARNING: Improper installation, adjustment, alteration, service or maintenance can cause property damage, personal injury, exposure to hazardous materials or loss of life.

Model No.	Net Blower Suction (in. WC)		Setting Tolerance
	Natural Gas	Propane	
1005A	-4.1	-4.3	± 0.2" WC
1505A	-4.1	-4.3	± 0.2" WC
2005A	-4.1	-4.3	± 0.2" WC

Table W. XTherm Air Pressure Settings

6.5.2. User Test

Set DIP switch #1 on the VERSA IC control to "ON". Set On Touchscreen, click Menu icon, Tools icon, Systems Tools, Press "Start" to initiate User Test sequence.

- User Test START is displayed.
- Pressing Hold/Skip button advance through the user test.
- The Boil MIN/MAX steps for burner operation are only run for enabled boilers.
- Local Heat/DHW/EMS demands **must** be present for burner operation.

Number Field	Output Action
SYS	System Pump relay turns on.
DHW	DHW Pump relay turns on.
PMP 1	System and Heater Pump relays turn on.
CWP	CWP Proportional output
Boil 1	Ignite Heater Burner.
Max 1	Ramp Heater to Max Fire and hold.
Min 1	Hold Heater at Min Fire.

Table X. User Test Fields

- On the first press of the Hold/Skip button, the test step is held and "HOLD" is flashed at 1Hz.
- On the second press of the Hold/Skip button, the test step is incremented.
- If heater outlet temperature reaches the PIM Hi-Limit, the heater will be ramped down to keep the temperature in a safe range.
- Press of the Hold/Skip button from Heater Max will End the User Test function.
- CWP MUST be enabled (VERSA DIP #3) VALVE must be functioning during USER TEST.

NOTE: If USER TEST is performed with Cold Water Protection enabled (VERSA DIP 3 = ON), allow valve or VS pump test sequence to complete uninterrupted or a fault condition may occur.

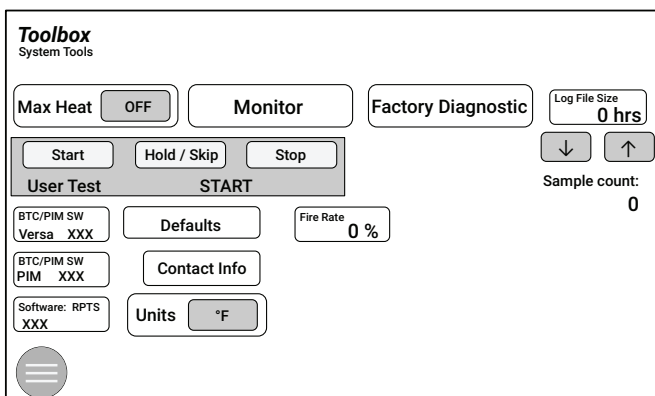

Figure 56. Touchscreen Toolbox Menu

6.5.3. Safety Inspection

1. Check all thermostats and high limit settings.
2. During the following safety checks leave manometers hooked up, check and record.
3. If other gas-fired appliances in the room are on the same gas main, check all pressures on the XTherm with all other equipment running.
4. Check thermostats for ON-OFF operation.
5. Check high limits for ON-OFF operation.
6. While in operation, check flow switch operation.
7. Check the low gas pressure switch (if provided). (For proper adjustment, use the attached manometers, if available, to set pressure. The scales on the switch are approximate only.) Low gas pressure switch (if provided) must be set at 3.0" WC for natural gas and propane gas.
8. Make sure that the high gas pressure switch is set to 3.0" WC for both natural gas and propane gas.

6.5.4. Finishing

Record all data on the "Start-up Checklist" located at the back of this manual.

Disconnect the manometers and reconnect the cap on the fan pressure tee and reinsert the sealing screws into the bleedle valves.

Start-up is complete and the heater should be operating properly.

6.5.5. Follow-Up

Safety checks must be recorded as performed.

Turn heater on. After main burner ignition:

1. Check manometer for proper readings.
2. Cycle heater several times and re-check readings.
3. Remove all manometers and replace caps and screws.
4. Check for gas leaks one more time.
5. To prepare for possible "limp-along" operation (if communication is ever lost between the VERSA and the PIM), set the operator Set Point potentiometer on the PIM (**See Figure 31**) to the desired target setpoint.

6.5.6. Leak Test Procedure: Dual-Seat Gas Valve

Proper leak testing requires three pressure test points in the gas train. Remove the upper front panel to access the gas valve for this test. **See Figure 57.**

Test point A is a bleedle valve located upstream of the combination gas valve on the supply manifold.

Test point B is a bleedle valve located between the two automatic gas valve seats.

Test point C is a bleedle valve located downstream of both automatic gas valve seats and upstream of the manual valve.

These tests are to be conducted with the electrical power to the heater turned OFF.

1. Manually close the downstream leak test valve.
2. Open the bleedle valve at test point A and connect a manometer to it. Verify that there is gas pressure and that it is within the proper range (NOTE: must not exceed 14.0" WC).
3. Open test point B and connect a rubber tube to it. Connect the other end of the tube to a manometer and look for a build-up of pressure. Increasing pressure indicates a leaking gas valve which must be replaced.
4. Next, close the upstream manual gas valve (field supplied) and remove the manometers from the bleedle valves in test point A and test point B. Connect a rubber tube from the test point A bleedle valve to the test point B bleedle valve and open the upstream manual gas valve. Make sure that test point A and B bleedle valves have been opened so as to allow gas to flow. This will bring gas pressure to the second valve seat.

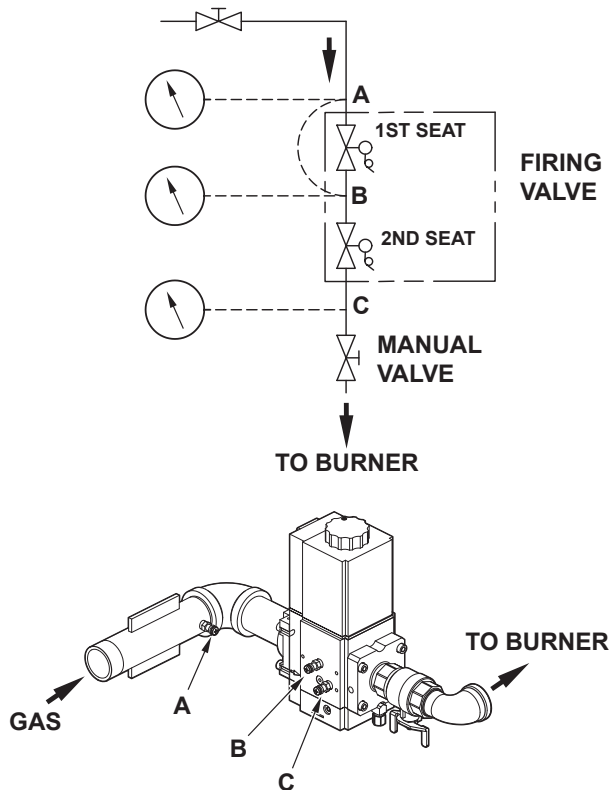

Figure 57. Leak Test Procedure

5. Open the bleedle valve at test point C and connect a second rubber tube to it. Connect the other end of the tube to a manometer and look for a build-up of pressure. Increasing pressure indicates a leaking gas valve which must be replaced.
6. Remove rubber tube and manometers. Close each bleedle valve as the tubes are removed.
7. After no leakage has been verified at all valve seats and test valve, open downstream leak test valve and restore electrical power to the heater.

6.5.7. Post Start-Up Check

Check off steps as completed:

1. Verify that the heater and heat distribution units are filled with water.
2. Verify that air has been purged from the system.
3. Verify that air has been purged from the gas piping, and that the piping has been checked for leaks.
4. Confirm that the proper start-up procedures were followed.
5. Inspect burner to verify flame.
6. Test safety controls: test low water cut-off or additional safety controls for operation as outlined by manufacturer. Burner should be operating and should go off when controls are tested. When safety devices are restored, burners should re-ignite after pre-purge time delay.
7. To test the fixed manual reset high limit built into the PIM, first set DIP switch #8 on the PIM to the ON position. This will activate a Commission Test Mode which will turn on the amber Alarm/Test LED on the PIM. The fixed high limit setting is temporarily overridden to match the setpoint potentiometer position on the PIM. The high limit can now be adjusted by the potentiometer to assist in commission testing and verification of high limit functionality. The VERSA IC will allow one-time operation of the limit and then must be returned to normal operation by turning DIP switch #8 back to the OFF position. Power to the unit must then be cycled off, then on to return to normal operation.
8. Test ignition system safety device:
 - a. Close manual gas valve. Turn power on.
 - b. Close Enable/Disable circuit to call for heat.
 - c. The burner should attempt three trials for ignition for the standard model and then lock out. Single-try ignition modules will try only once and then lock out.
 - d. Open manual gas valve. Reset the ignition control by pressing for one second and then releasing the reset button adjacent the user interface or at the PIM to clear the ignition fault.

9. To restart system, follow lighting instructions in the Operation section.
10. Check to see that the high limit control is set above the design temperature requirements of the system. For multiple zones: Check to make sure the flow is adjusted as required in each zone.
11. Check that the heater is cycled with the thermostat. Raise the setting on the thermostat to the highest setting and verify that the heater goes through the normal start-up cycle. Reduce to the lowest setting and verify that the heater goes off.
12. Observe several operating cycles for proper operation.
13. Set the heater thermostat to desired temperature.
14. Review all instructions shipped with this heater with owner or maintenance person, return to envelope and give to owner or place the instructions inside front panel on heater.

7. OPERATION

7.1. Lighting Instructions

1. Before operation, make sure you have read all of the safety information in this manual.
2. Remove upper front panel.
3. Set the thermostat to the lowest setting.
4. Turn off all electrical power to the appliance.
5. This appliance is equipped with an ignition device which automatically lights the burner. Do not try to light the burner by hand.
6. Turn on main manual gas valve field-installed near gas inlet connection on back of heater.
7. Wait 5 minutes to clear out any gas. Then smell for gas, especially near the floor. If you then smell gas, STOP! Follow the steps in the safety information on the front cover of this manual. If you do not smell gas, go to next step.

Turn on all electrical power to the appliance.

Set thermostat to desired setting. The appliance will operate. The igniter will glow after the pre-purge time delay (15 seconds). After igniter reaches temperature (30 seconds) the main valve should open for a 4-second trial for ignition. System will try for ignition up to three times (one time on optional single-try ignition module). If flame is not sensed, lockout will commence.

8. If the appliance will not operate, follow the instructions "To Turn Off Gas To Appliance", and call your service technician or gas supplier.

9. Replace upper front panel.
10. If heater fails to start, verify the following:
 - a. There are no loose connections or that the service switch is off or in the powered, but disabled position.
 - b. High temperature limit switch (optional) is set above water temperature or manual reset high limit is not tripped.
 - c. Enable/Disable circuit is closed.
 - d. Gas is on at the meter and the heater.
 - e. Incoming dynamic gas pressure to the gas valve is NOT less than 4.0" WC for natural gas or propane gas.

7.2. To Turn Off Gas To Appliance

1. Shut off manual gas valve field installed near gas inlet connection on back of heater.
2. Remove upper front panel.
3. Move 3-position rocker switch to "OFF" position.
4. Turn off all electrical power to the appliance if service is to be performed.
5. Replace access panel.

8. TROUBLESHOOTING

8.1. XTherm Error Codes

If any of the sensors detect an abnormal condition or an internal component fails during the operation of the XTherm, the display may show the error. This code may either be the result of a temporary condition in which case the display will revert to its normal readout when the condition is corrected, or it may be the result of a condition that the controller has evaluated as not safe to restart the unit. In this case, the unit control will be locked out, requiring the maintenance person to manually reset the control by pressing and releasing the RESET button.

8.2. Heater Errors

When an error condition occurs, the controller will display an error code on the touch screen display. These error codes and several suggested corrective actions are included in the XTherm Fault Text section on the following page. See **Table X** and **Table Y**.

8.3. Heater Faults

1. When a fault condition occurs, the controller will flash a red light on the PIM and display the error code on the user interface. The alarm output will also be activated. Most fault conditions will also cause the heater pump to run in an attempt to cool the unit.

2. Note the error code, either through the flash code on the PIM and/or from the Toolbox menu on the user interface, and reference the explanation of the fault along with troubleshooting steps in the XTherm fault text section.
3. Investigate and correct the cause of the fault.
4. Press and release the RESET key to clear the fault on the user interface and resume operation. Be sure to observe the operation of the unit for a period of time to ensure correct operation and no reoccurrence of fault code(s).

8.4. Raymote Troubleshooting

Please refer to the Raymote installation and operation manual (5000.721).

⚠ WARNING: When servicing or replacing any components of this unit be certain that:

- The gas is off.
- All electrical power is disconnected.

⚠ WARNING: Do not use this appliance if any part has been under water. Improper or dangerous operation may result. Contact a qualified service technician to inspect the heater and to repair or replace any part of the heater that has been under water prior to placing the heater back in operation.

⚠ DANGER: When servicing or replacing components that are in direct contact with the water, be certain that:

- There is no pressure in the heater. (Pull the release on the relief valve. Do not depend on the pressure gauge reading).
- The heater water is not hot.
- The electrical power is off.

⚠ CAUTION: Wiring errors can cause improper and dangerous operation. Verify proper operation after servicing. See wiring diagram.

⚠ CAUTION: If overheating occurs or the gas supply fails to shut off, do not turn off electrical power to the circulating pump. This may aggravate the problem and increase the likelihood of heater damage. Instead, shut off the gas supply to the heater at the gas service valve.

8.5. XTherm Fault Text

8.5.1. Error Display

If there is an active error, then it is displayed as the first item in the Toolbox Menu and it is the default display for the control until the error is resolved.

Error Item	Description and Troubleshooting
OUTLET SEN	Check the outlet water sensor and its wiring
LIMIT SEN	Check the high limit sensor and its wiring
INLET SEN	Check the inlet sensor and its wiring
GAS PRESS	Check PIM wiring
IGNITION	Reset control, push and release RESET button
LIMIT TRIP	Heater temperature tripped the high limit
FLAME	False flame detected. Shut off gas supply, recycle power
ID CARD	Identity card, check ID card and wiring
IGN CTRL	Internal control fault. Reset power, replace control
DELTA T	Temperature difference between the inlet and outlet exceeded the set point. Check water flow
LOW 24VAC	Low 24 VAC power. Check power supply wiring and transformer
BLOW SPEED	Blower speed out of range. Check blower wiring and blower
FLOW ERROR	The unit is not detecting enough flow to allow ignition sequence to take place
UNDER FLOW	The flow reading has drop under minimum requirements to keep the current operation point
FLOW WARNING	Operation conditions do not match current flow reading

Table Y. Error Display

8.5.2. LED Error Code Listing

Active errors detected are indicated by LED lights on the PIM.

Error Mode	LED Flash Code on PIM	Recommended Troubleshooting
Normal Operation	Red LED OFF	
ID Card Fault	Red LED Steady ON, Green Power LED OFF	Check that the proper ID Card is securely connected. Perform a power and system reset
Internal Control Fault	Red LED Steady ON	Perform a power and system reset. If the fault remains, replace the PIM
N/A	Red LED – 1 Flash	N/A
False Flame Error	Red LED – 2 Flashes	Check for proper gas valve closure. Clean burner and electrodes
Ignition Lockout Fault	Red LED – 3 Flashes	Check the gas supply. Check transformer. Check igniters. Check wiring. Press reset button on PIM/membrane switch. Recycle power
Ignition Proving Current Fault	Red LED – 4 Flashes	Check HSI element. Replace as necessary.
Low Voltage Fault	Red LED – 5 Flashes	Check the 24VAC input voltage – the voltage must be above 18.0VAC for proper operation. Replace transformer as necessary
N/A	Red LED – 6 Flashes	N/A
Hi-Limit Fault	Red LED – 7 Flashes	Check for proper water flow. Check hi-limit setting and outlet sensor.
Sensor Fault	Red LED – 8 Flashes	Check the VERSA IC Control for fault identification. Check sensor and wiring
N/A	Red LED – 9 Flashes	Check wiring at J8, pins 1 and 3 for loose or missing jumper
Water Pressure Fault	Red LED – 10 Flashes	Check system piping for leaks. Check water pressure switch (if equipped) and connections. Check wiring on PIM at J1, pins 6 and 7 for loose or missing jumper
Blower Speed Fault	Red LED – 11 Flashes	Verify the tachometer signal and the connections at terminals J5 on the PIM. Confirm power to heater is at or above minimum required
N/A	Red LED – 12 Flashes	Check wiring on PIM at J1, pins 3 and 4 for loose or missing jumper.
Hi-Temperature Delta Fault	Red LED – 13 Flashes	Check pumps operation. Confirm proper water flow across heat exchanger (Delta T)
Ft_bus Communications Fault	Red LED – 14 Flashes	Verify that the VERSA IC Control is connected and operating properly. Check the cable between the PIM and the VERSA IC Control
General limit circuit fault	Red LED – 15 Flashes	Check the VERSA IC for fault indication and troubleshooting information

Table Z. PIM LED Error Codes

8.5.3. Sensor Resistance Values

Water Sensor / Outdoor Sensor	
Water Temperature	Resistance (ohms)
32°F (0°C)	32550
41°F (5°C)	25340
50°F (10°C)	19870
59°F (15°C)	15700
68°F (20°C)	12490
77°F (25°C)	10000
86°F (30°C)	8059
95°F (35°C)	6535
104°F (40°C)	5330
113°F (45°C)	4372
122°F (50°C)	3605
131°F (55°C)	2989
140°F (60°C)	2490
149°F (65°C)	2084
158°F (70°C)	1753
167°F (75°C)	1481
176°F (80°C)	1256
185°F (85°C)	1070
194°F (90°C)	915
203°F (95°C)	786
212°F (100°C)	667

Table AA. Approximate Sensor Resistance Values

9. MAINTENANCE

9.1. Suggested Minimum Maintenance Schedule

Regular service by a qualified service agency and maintenance must be performed to ensure maximum operating efficiency.

Daily and monthly maintenance as outlined below may be performed by onsite maintenance staff.

9.1.1. Daily

1. Check that the area where the heater is installed is free from combustible materials, gasoline, and other flammable vapors and liquids.
2. Check for and remove any obstruction to the flow of combustion or ventilation air to heater.

9.1.2. Monthly

1. Check for piping leaks around pumps, mixing valves, relief valves, and other fittings. If found, repair at once. DO NOT use petroleum-based stop-leak compounds.
2. Visually inspect venting system for proper function, deterioration or leakage.
3. Visually inspect for proper operation of the condensate drain in the venting. If leaks are observed repair at once.
4. Check air vents for leakage.

9.1.3. Yearly (Beginning of each Heating Season)

Schedule annual service by qualified service agency.

1. Visually check top of vent for soot. Call service person to clean. Some sediment at bottom of vent is normal.
2. Visually inspect venting system for proper function, deterioration or leakage. Ensure that condensate drain is inspected and ensure that condensate is being directed to appropriate condensate treatment system or drain, as required by local codes.
3. Check that area is free from combustible materials, gasoline, and other flammable vapors and liquids.
4. Check air filter and replace as necessary.
5. Follow pre-start-up check in the Start-up section.
6. Check flame strength signal as noted on display Remove and visually inspect hot surface igniter and sensor for damage, cracking or debris build-up.
7. Check operation of safety devices. Refer to manufacturer's instructions.

8. Follow oil-lubricating instructions on pump (if re-quired). Over-oiling will damage pump. Water-lubricated circulators do not need oiling.
9. To avoid potential of severe burn, DO NOT REST HANDS ON OR GRASP PIPES. Use a light touch; return piping will heat up quickly.
10. 1Check blower and blower motor.
11. 1Check for piping leaks around pumps, relief valves and other fittings. Repair, if found. DO NOT use petroleum-based stop-leak.

9.1.4. Periodically

1. Check relief valve. Refer to manufacturer's instructions on valve.
2. Test low water cut-off. Refer to manufacturer's instructions.
3. Check and clean strainer in y-strainer or suction diffuser for debris, if equipped.

9.2. Preventive Maintenance Schedule

The following procedures are recommended and are good practice for all XTherm installations.

9.2.1. Daily

1. Check gauges, monitors and indicators.
2. Check instrument and equipment settings. See "Post Start-Up Check" on **page 51**.

9.2.2. Weekly

For low-pressure heaters, test low-water cut-off device. (With heater in pre-purge, depress the low water cut-off test button. Appliance should shut-off and ignition fault light should come on. Depress reset button on front of junction box panel to reset).

9.2.3. Monthly

1. Check flue, vent, stack, or outlet dampers.
2. Test blower air pressure. See "Blower Check" on **page 49**.
3. Test high and low gas pressure interlocks, if equipped. See "Safety Inspection" on **page 50**.

9.2.4. Semi-Annually

1. Recalibrate all indicating and recording gauges.
2. Check flame failure detection system components.
3. Confirm firing rate on the unit by clicking on the view icon and selecting the Master Info screen.
4. Check piping and wiring of all interlocks and shut-off valves.
5. Check air filter and replace as necessary.

9.2.5. Annually

1. Test flame failure detection system and pilot turndown.
2. Test high limit and operating temperature. See "Post Start-Up Check" on **page 51**.
3. Check flame sensor.
4. Conduct a combustion test at full fire. Carbon dioxide should be $9.0\% \pm 0.4\%$ at full fire for natural gas, and $10.3\% \pm 0.4\%$ for propane gas. Carbon monoxide should be less than 100 ppm.
5. **For Models H and WH only:** Check emission at minimum fire and record CO and CO₂ reading. CO must be less than 100 ppm for all fuels. CO₂ must be between 7.5% and 9.5% for natural gas, 8.0% and 10.5% for propane gas. If CO and CO₂ are not within these ranges, stop running the unit and contact your Raypak representative.
6. Check valve coil for 60-cycle hum or buzz. Check for leaks at all valve fittings using a soapy water solution (while heater is operating). Test other operating parts of all safety shut-off and control valves and increase or decrease settings (depending on the type of control) until the safety circuit opens. Reset to original setting after each device is tested.
7. Perform leakage test on gas valves. See **Figure 57**.
8. Inspect and clean burner using shop air.
9. Drain heat exchanger and inspect the water side visually for build up or debris by removing inlet stub pipe or suction diffuser inspection cover.

9.2.6. As Required

1. Recondition or replace low water cut-off device.
2. Check sediment trap and gas strainers.
3. Check flame failure detection system. See "Post Start-Up Check" on **page 51**.
4. Check igniter. Resistance reading should be 40-75 ohms at 77°F (25°C).
5. Check flame signal strength. (Flame signal should be greater than 1 **microampere** as measured at the 2 pins on the bottom of the PIM).
6. Confirm firing rate on the unit by clicking on the view icon and selecting the Master Info screen. Also confirm the air pressure settings and combustion settings as described in the "**6.5.1. Blower Check**" on **page 49**.
7. Test safety/safety relief valves in accordance with ASME Heater and Pressure Vessel Code Section IV.

NOTE: Technician performing the periodic check up must carry a calibrated combustion analyzer to ensure desired combustion levels are being maintained.

9.3. Filter Maintenance

NOTE: Use Raypak replacement filters, for models 0856 - 1506 kit number 016860F; for models 1756 - 3006 kit number 012552F.

- Inspect quarterly.
- Replace as needed. The recommended interval is once per year.

10. APPENDIX

10.1. Inside Air Contamination

All heaters experience some condensation during start-up. The condensate from flue gas is acidic. Combustion air can be contaminated by certain vapors in the air which raise the acidity of the condensate. Higher acidity levels attack many materials including stainless steel, which is commonly used in high efficiency systems. The heater can be supplied with corrosion-resistant, non-metallic intake air vent material. You may, however, choose to use outside combustion air for one or more of these reasons:

1. Installation is in an area containing contaminants listed below which will induce acidic condensation.
2. You want to reduce infiltration into your building through openings around windows and doors.
3. You are using AL29-4C stainless steel, PVC, CPVC or Polypropylene vent pipe, which is more corrosion-resistant than standard metallic vent pipe. In extremely contaminated areas, this may also experience deterioration.

Products causing contaminated combustion air:

- spray cans containing chloro/fluorocarbons
- permanent wave solutions
- chlorinated waxes/cleaners
- chlorine-based swimming pool chemicals
- calcium chloride used for thawing
- sodium chloride used for water softening
- refrigerant leaks
- paint or varnish removers
- hydrochloric acid/muriatic acid
- cements and glues
- antistatic fabric softeners used in clothes dryers
- chloride-type bleaches, detergents, and cleaning solvents found in household laundry rooms
- adhesives used to fasten building products
- similar products

Areas where contaminated combustion air commonly exists:

- dry cleaning/laundry areas
- metal fabrication plants
- beauty shops
- refrigeration repair shops
- photo processing plants
- auto body shops
- plastic manufacturing plants
- furniture refinishing areas and establishments
- new building construction
- remodeling areas
- open pit skimmers

Check for areas and products listed above before installing heater. If found:

- remove products permanently, OR
- install TruSeal direct vent.

11. IMPORTANT INSTRUCTIONS FOR THE COMMONWEALTH OF MASSACHUSETTS

The Commonwealth of Massachusetts requires compliance with regulation 248 CMR 4.00 and 5.00 for installation of through – the – wall vented gas appliances as follows:

(a) For all side wall horizontally vented gas fueled equipment installed in every dwelling, building or structure used in whole or in part for residential purposes, including those owned or operated by the Commonwealth and where the side wall exhaust vent termination is less than seven (7) feet above finished grade in the area of the venting, including but not limited to decks and porches, the following requirements shall be satisfied:

1. INSTALLATION OF CARBON MONOXIDE DETECTORS.

At the time of installation of the side wall horizontal vented gas fueled equipment, the installing plumber or gasfitter shall observe that a hard wired carbon monoxide detector with an alarm and battery back-up is installed on the floor level where the gas equipment is to be installed. In addition, the installing plumber or gasfitter shall observe that a battery operated or hard wired carbon monoxide detector with an alarm is installed on each additional level of the dwelling, building or structure served by the side wall horizontal vented gas fueled equipment. It shall be the responsibility of the property owner to secure the services of qualified licensed professionals for the installation of hard wired carbon monoxide detectors

a. In the event that the side wall horizontally vented gas fueled equipment is installed in a crawl space or an attic, the hard wired carbon monoxide detector with alarm and battery back-up may be installed on the next adjacent floor level.

b. In the event that the requirements of this subdivision can not be met at the time of completion of installation, the owner shall have a period of thirty (30) days to comply with the above requirements; provided, however, that during said thirty (30) day period, a battery operated carbon monoxide detector with an alarm shall be installed.

2. APPROVED CARBON MONOXIDE DETECTORS. Each carbon monoxide detector as required in accordance with the above provisions shall comply with NFPA 720 and be ANSI/UL 2034 listed and IAS certified.

3. SIGNAGE. A metal or plastic identification plate shall be permanently mounted to the exterior of the building at a minimum height of eight (8) feet above grade directly in line with the exhaust vent terminal for the horizontally vented gas fueled heating appliance or equipment. The sign shall read, in print size no less than one-half (1/2) inch in size, "GAS VENT DIRECTLY BELOW. KEEP CLEAR OF ALL OBSTRUCTIONS".

4. INSPECTION. The state or local gas inspector of the side wall horizontally vented gas fueled equipment shall not approve the installation unless, upon inspection, the inspector observes carbon monoxide detectors and signage installed in accordance with the provisions of 248 CMR 5.08(2)(a)1 through 4.

(b) EXEMPTIONS: The following equipment is exempt from 248 CMR 5.08(2)(a)1 through 4:

1. The equipment listed in Chapter 10 entitled "Equipment Not Required To Be Vented" in the most current edition of NFPA 54 as adopted by the Board; and

2. Product Approved side wall horizontally vented gas fueled equipment installed in a room or structure separate from the dwelling, building or structure used in whole or in part for residential purposes.

(c) MANUFACTURER REQUIREMENTS - GAS EQUIPMENT VENTING SYSTEM PROVIDED. When the manufacturer of Product Approved side wall horizontally vented gas equipment provides a venting system design or venting system components with the equipment, the instructions provided by the manufacturer for installation of the equipment and the venting system shall include:

1. Detailed instructions for the installation of the venting system design or the venting system components; and

2. A complete parts list for the venting system design or venting system.

(d) MANUFACTURER REQUIREMENTS - GAS EQUIPMENT VENTING SYSTEM NOT PROVIDED. When the manufacturer of a Product Approved side wall horizontally vented gas fueled equipment does not provide the parts for venting the flue gases, but identifies "special venting systems", the following requirements shall be satisfied by the manufacturer:

1. The referenced "special venting system" instructions shall be included with the appliance or equipment installation instructions; and

2. The "special venting systems" shall be Product Approved by the Board, and the instructions for that system shall include a parts list and detailed installation instructions.

(e) A copy of all installation instructions for all Product Approved side wall horizontally vented gas fueled equipment, all venting instructions, all parts lists for venting instructions, and/or all venting design instructions shall remain with the appliance or equipment at the completion of the installation.

GAS PRESSURE SUPERVISION

The Commonwealth of Massachusetts requires listed high and low gas pressure switches (manual reset) for any model with a maximum firing input greater than 1,000,000 Btu/Hr in accordance with 248 CMR 7.04(11)(d).

A gas pressure regulator (field supplied) is required in the gas train ahead of the heater, for heaters having input rates greater than 1,000,000 Btu/Hr, in accordance with 248 CMR 7.04 Figure 3B requirements.

START-UP CHECKLIST FOR FAN-ASSISTED RAYPAK PRODUCTS

This start-up checklist is to be completely filled out by the service technician starting up the Raypak boilers or heaters for the first time. All information may be used for warranty purposes and to ensure that the installation is correct. Additionally this form will be used to record all equipment operation functions and required settings.

GAS SUPPLY DATA

Regulator Model & Size _____ / _____ CFH
 Gas Line Size (in room) _____ In. NPT
 Length of Gas Line _____ Eq Ft
 Low Gas Pressure Setting _____ In. WC
 High Gas Pressure Setting _____ In. WC
 Gas Shut-Off Valve Type _____
 (Ball, Lube cock)
 Port _____ Std _____ Full

CLEARANCES

Front Clearance _____ In.
 Right Side Clearance _____ In.
 Left Side Clearance _____ In.
 Rear Clearance _____ In.
 Overhead Clearance _____ In.

ELECTRICAL

Voltage Supply (VAC) _____ No Load _____
 _____ Load _____
 Voltage -24 VAC _____ VAC
 Voltage Com to Ground _____ VAC
 Hot Surface Igniter _____ Ohms
 Auto High Limit Setting _____ deg F
 Manual Reset High-Limit Setting _____ deg F
 Operating Control Setting _____ deg F

VISUAL INSPECTION OF COMPONENTS

Verify inspection was done and condition of components are in good working order with a "yes"

Wiring Harness _____ Y/N
 Burner (flame) _____ Y/N
 Refractory (Visual) _____ Y/N
 Remote flame sense _____ Y/N
 Covers in place for outdoor _____ Y/N

Sketch plumbing on reverse side

VENTING

Vent Size: _____ Stack Height: _____
 Vent Material: _____ sketch vent on reverse side ***
 Vent Termination Type: _____
 Combustion Air Openings: Low _____ in²
 Ventilation Air High _____ in²

WATER SUPPLY

Flow Rate in GPM or Delta T _____ If Avail
 Measure flow rate at full fire
 Pump Purge setting _____ Minutes
 Low Water Cutoff _____ Test
 Plumbing Size _____
 Pump Size: _____ (Boiler) Pump HP: _____
 Impeller trim _____ Pump Model _____
 Louvers _____ Screens _____

HO₂T (If equipped)

O₂ sensor cable is connected to the O₂ sensor _____
 DDC power switch is in the ON position _____
 Maintenance switch is in the OFF position _____
 Actuator stops are in the correct position _____

RAYMOTE (If equipped)

Wi-Fi signal available in boiler room _____
 Boiler provisioned with valid WiFi credentials _____
 Wi-Fi signal strength (RRSI > -80) _____

EMISSIONS SETTINGS AND TEST INFORMATION

	(AT FULL FIRE)	(AT MIN. FIRE)
Blower Suction Pressure	_____ In. WC	_____ In. WC
Supply Gas Pressure	_____ In. WC	_____ In. WC

Verify stable pressure static and dynamic condition

Nominal Factory Recommended Settings

See manual or card tag
 See manual or card tag

The following measurements must be obtained with a calibrated combustion analyzer.

O ₂	_____ %	_____ %	See manual
CO	_____ PPM	_____ PPM	Less than 100 PPM
CO ₂	_____ %	_____ %	See manual

Model Number: _____

Serial Number: _____

*** Note: draw venting with details, such as extractors, barometric dampers, blast dampers or draft inducers

Site Elevation Above Sea Level _____ Ft.

Job Name _____
 Address _____
 Physical Location of Boiler: Indoors _____; Outdoors _____; Ground Level _____; Roof _____; Below Grade _____
 Mechanical Contractor / Installer _____
 Date and Time of Start-up _____ Print Name and Signature of Start-up Technician _____

Information must be faxed to: (805) 278-5496 in order to ensure warranty consideration Attn: Service Manager

**LIMITED WARRANTY
X THERM - TYPES H AND WH
Models: 1005A - 2005A, 2505 - 4005**

SCOPE

Raypak, Inc. ("Raypak") warrants to the original owner that all parts of this heater which are actually manufactured by Raypak will be free from failure under normal use and service for the specified warranty periods and subject to the conditions set forth in this Warranty. Labor charges and other costs for parts removal or reinstallation, shipping and transportation are not covered by this Warranty but are the owner's responsibility.

EFFECTIVE DATE

The Effective Date of this Limited Warranty is the date of original installation if properly documented; if you are not able to provide documentary proof of the date of original installation, the Effective Date will be the date of manufacture plus 30 days.

HEAT EXCHANGER WARRANTY PERIODS

PRIMARY

Domestic Hot Water

Five (5) years from date of heater installation. Includes copper heat exchanger with bronze waterways.

Ten (10) years from date of heater installation. Includes only cupro-nickel heat exchanger with bronze waterways.

Space Heating (Closed Loop System)

Ten (10) years from date of heater installation. Includes cupro-nickel or copper heat exchanger with bronze or cast iron waterways.

Thermal Shock Warranty

Twenty five (25) years from date of heater installation against "Thermal Shock" (excluded, however, if caused by heater operation at large changes exceeding 150°F between the water temperature at intake and heater temperature, or operating at heater temperatures exceeding 230°F).

Stainless Steel Condensing Heat Exchanger

Ten (10) years from date of heater installation.

ANY OTHER PART MANUFACTURED BY RAYPAK

One (1) year warranty from date of heater installation, or eighteen (18) months from date of factory shipment based on Raypak's records, whichever comes first.

SATISFACTORY PROOF OF INSTALLATION DATE, SUCH AS INSTALLER INVOICE, IS REQUIRED. THIS WARRANTY WILL BE VOID IF THE HEATER RATING PLATE IS ALTERED OR REMOVED.

ADDITIONAL WARRANTY EXCLUSIONS

This warranty does **NOT** cover failures or malfunctions resulting from:

1. Failure to properly install, operate or maintain the heater in accordance with our printed instructions provided;
2. Abuse, alteration, accident, fire, flood and the like;
3. Sediment or lime build-up, freezing, or other conditions causing inadequate water circulation;
4. High velocity flow exceeding heater design rates;
5. Failure of connected system devices, such as pump or controller;
6. Use of non-factory authorized accessories or other components in conjunction with the heater system;
7. Failing to eliminate air from, or replenish water in, the connected water system;
8. Chemical contamination of combustion air or use of chemical additives to water.

PARTS REPLACEMENT

Under this Warranty, Raypak will furnish a replacement for any failed part. The failed part must first be returned to Raypak if requested, with transportation charges prepaid, and all applicable warranty conditions found satisfied. The replacement part will be warranted for only the unexpired portion of the original warranty. Raypak makes no warranty whatsoever on parts not manufactured by it, but Raypak will apply any such warranty as may be provided to it by the parts manufacturer.

HOW TO MAKE A WARRANTY CLAIM

Promptly notify the original installer, supplying the model and serial numbers of the unit, date of installation and description of the problem. The installer must then notify his Raypak distributor for instructions regarding the claim. If either is not available, contact Service Manager, Raypak, Inc., 2151 Eastman Avenue, Oxnard, CA 93030 or call (805) 278-5300. In all cases proper authorization must first be received from Raypak before replacement of any part.

EXCLUSIVE WARRANTY-LIMITATION OF LIABILITY

This is the only warranty given by Raypak. No one is authorized to make any other warranties on Raypak's behalf. **THIS WARRANTY IS IN LIEU OF ALL OTHER WARRANTIES, EXPRESS OR IMPLIED, INCLUDING BUT NOT LIMITED TO IMPLIED WARRANTIES OF MERCHANTABILITY AND FITNESS FOR A PARTICULAR PURPOSE. RAYPAK'S SOLE LIABILITY AND THE SOLE REMEDY AGAINST RAYPAK WITH RESPECT TO DEFECTIVE PARTS SHALL BE AS PROVIDED IN THIS WARRANTY. IT IS AGREED THAT RAYPAK SHALL HAVE NO LIABILITY, WHETHER UNDER THIS WARRANTY, OR IN CONTRACT, TORT, NEGLIGENCE OR OTHERWISE, FOR ANY SPECIAL, CONSEQUENTIAL, OR INCIDENTAL DAMAGE, INCLUDING DAMAGE FROM WATER LEAKAGE.** Some states do not allow limitations on how long an implied warranty lasts, or for the exclusion of incidental or consequential damages. So the above limitation or exclusion may not apply to you.

THIS LIMITED WARRANTY GIVES YOU SPECIFIC LEGAL RIGHTS. YOU MAY ALSO HAVE OTHER RIGHTS WHICH MAY VARY FROM STATE TO STATE. We suggest that you complete the information below and retain this certificate in the event warranty service is needed. Reasonable proof of the effective date of the warranty (date of installation) must be presented, otherwise, the effective date will be based on the rate of manufacture plus thirty (30) days.

DO NOT RETURN THIS DOCUMENT TO RAYPAK. KEEP IT WITH YOUR HEATER OR BUSINESS RECORDS.

Name of Owner	Name of Installer
Owners Address	Installers Address
Date of Heater Installation	Telephone Number of Installer
Model Number of Your Heater	Serial Number of Your Heater

RAYPAK, INC., 2151 Eastman Avenue, Oxnard, CA 93030 • (805) 278-5300 FAX (800) 872-9725

LIMITED WARRANTY
XTHERM PROFESSIONAL SERIES POOL HEATER
Models: P1005A thru P4005A

SCOPE OF WARRANTY

Raypak, Inc. (Raypak) warrants to the original owner that the above model gas pool and spa heater (the "Heater") when installed in the 50 states of the United States of America with a pool or spa by a properly licensed installer will be free from defects in materials and workmanship under normal use and service for the Applicable Warranty Period. Under this Limited Warranty, Raypak will, at its option, repair or furnish a replacement for any defective part of the HEATER. The repair or replacement will be warranted for only the unexpired portion of the original Applicable Warranty Period.

EFFECTIVE DATE

The Effective Date of Warranty coverage is the date of original installation if properly documented; otherwise it is the date of manufacture plus 30 days. All Applicable Warranty Periods specified in this Limited Warranty are measured from the Effective Date.

APPLICABLE WARRANTY PERIOD

If the HEATER is installed with a pool or spa, the Applicable Warranty Period is one (1) year from the Effective Date, parts and labor, for the HEATER and component parts, except that the cupro-nickel heat exchanger will have an Applicable Warranty Period of five (5) years from the Effective Date, with no labor coverage in the second thru fifth years. The stainless steel condensing heat exchanger is ten (10) years from Effective Date, with no labor coverage in the second through tenth years,

LABOR AND SHIPPING COSTS

This Limited Warranty covers the reasonable cost of labor for repairs or replacements covered by this Limited Warranty up to \$1000 per heater, provided that said repairs or replacements are performed by a Raypak designated service provider during the Applicable Warranty Period and Raypak has pre-authorized said repair or replacement. This Limited Warranty does not cover any travel time or other labor costs. Furthermore, this Limited Warranty does not cover any shipping costs to and from the service provider or to or from the installation site. All of the foregoing costs and expenses are your responsibility.

WARRANTY EXCLUSIONS

This Limited Warranty does **NOT** apply;

1. if the Heater has been moved from its original place of installation, or if the original owner no longer owns the property where the original installation was made;
2. if the Heater is not properly installed with a pool or spa by a qualified licensed installer in accordance with applicable local codes and ordinances, good trade practices, and the manufacturer's installation instructions. Not to be installed in a closed loop hydronic heating, or potable water heating application;
3. if the rating plate(s) or serial number(s) are altered or removed;
4. if the Heater is modified in any way, or non-factory authorized accessories or other components are used in conjunction with the Heater;
5. to damage, malfunctions or failures resulting from failure to properly install, operate or maintain the Heater in accordance with the manufacturer's instructions;
6. to damage, malfunctions or failures resulting from abuse, act of nature, accident, fire, flood, freeze, lightning or the like;
7. to damage, malfunctions or failures resulting from connected system control devices;
8. performance problems caused by improper sizing of the Heater or electric service voltage, wiring or fusing;
9. use of any attachment, including without limitation, any energy saving device not authorized by the manufacturer;

- to damage, malfunctions or failures resulting from misuse or neglect, including but not limited to, freeze-ups, operating the Heater with the cabinet door off, having flow restrictions or obstructions between the Heater outlet and the pool/spa, electrolysis due to an improperly installed salt chlorine generator, or not maintaining a proper chemical balance (PH level must be between 7.4 and 7.8 and total alkalinity between 100 and 150 PPM. Total dissolved solids (TDS) must be no greater than 3000 PPM. In salt water chlorinated pools, TDS must be no greater than 4500 PPM).

HOW TO MAKE A WARRANTY CLAIM

You should immediately notify your dealer and provide proof of purchase model number serial number and date of installation. Your dealer will contact Raypak for instructions regarding the claim and to determine the location of the nearest authorized service center. If the dealer is not available, please contact Raypak warranty service at 805-278-5300. When making a claim please be ready to supply the model number, serial number, date of original installation and a description of the problem. **Proper authorization MUST be obtained PRIOR to any repairs for the Limited Warranty to apply. This Limited Warranty is VOID if the Heater is repaired or altered in any way by ANY persons or agencies other than those authorized by Raypak.** Raypak reserves the right at all times to inspect, or require the return of, the defective Heater or component part and to verify warranty coverage at its factory.

EXCLUSIVE WARRANTY-LIMITATION OF LIABILITY

THE LIMITED WARRANTY IS THE ONLY WARRANTY GIVEN BY RAYPAK IN CONNECTION WITH THE HEATER AND ITS COMPONENT PARTS. NO ONE IS AUTHORIZED TO MAKE ANY OTHER WARRANTIES ON RAYPAK'S BEHALF. ANY IMPLIED WARRANTIES, INCLUDING MERCHANTABILITY OR FITNESS FOR A PARTICULAR PURPOSE, SHALL NOT EXTEND BEYOND THE APPLICABLE WARRANTY PERIOD SPECIFIED ABOVE. RAYPAK'S SOLE LIABILITY WITH RESPECT TO ANY DEFECT SHALL BE AS SET FORTH IN THIS LIMITED WARRANTY. IT IS AGREED THAT RAYPAK SHALL HAVE NO LIABILITY WHETHER UNDER THIS LIMITED WARRANTY OR IN CONTRACT, TORT OR NEGLIGENCE OR OTHERWISE FOR CLAIMS FOR SPECIAL, INCIDENTAL OR CONSEQUENTIAL DAMAGES (INCLUDING NO LIABILITY FOR DAMAGE FROM WATER LEAKAGE), ALL OF WHICH ARE EXPRESSLY EXCLUDED. SOME STATES DO NOT ALLOW LIMITATIONS ON HOW LONG AN IMPLIED WARRANTY LASTS, OR FOR THE EXCLUSION OF INCIDENTAL OR CONSEQUENTIAL DAMAGES, SO THE ABOVE LIMITATION OR EXCLUSION MAY NOT APPLY TO YOU. THIS LIMITED WARRANTY GIVES YOU SPECIFIC LEGAL RIGHTS, AND YOU MAY ALSO HAVE OTHER RIGHTS WHICH VARY FROM STATE TO STATE.

We suggest you immediately record the model and serial number and date of original installation and retain this Limited Warranty Certificate in the event warranty service is needed.

DO NOT RETURN THIS DOCUMENT TO RAYPAK. KEEP IT WITH YOUR POOL HEATER OR BUSINESS RECORDS.

Name of Owner	Name of Installer
Owners Address	Installers Address
Date of Pool Heater Installation	Telephone Number of Installer
Model Number of Your Pool Heater	Serial Number of Your Pool Heater

RAYPAK, INC., 2151 Eastman Avenue, Oxnard, CA 93030 • (805) 278-5300 FAX (800) 872-9725

p/n 241642



www.raypak.com

Raypak, Inc., 2151 Eastman Avenue, Oxnard, CA 93030 (805) 278-5300 Fax (805) 278-5468
Litho in U.S.A.