



Designed for Fun, Built to Last™

14' CHALLENGER SHUFFLEBOARD TABLE ASSEMBLY INSTRUCTIONS



Questions, problems, missing parts?

Contact Blue Wave Customer Service at 1-800-759-0977, Monday – Friday,
8am – 5pm (CST).

THANK YOU!

Thank you for purchasing this product. We work around the clock and around the globe to ensure that our products maintain the highest possible quality. However, in the rare case of issues during assembly or use of this product, please contact our Consumer Hotline at **800-759-0977** for immediate assistance before contacting your retailer. Please read the warranty information at the back of these assembly instructions for further details.

ASSEMBLY TIPS

IMPORTANT! PLEASE READ THESE ASSEMBLY INSTRUCTIONS IN ENTIRETY BEFORE ASSEMBLING YOUR PRODUCT.

1. Find a clean, level surface to begin the assembly of your game table. We recommend that two adults work together to assemble this game. You may want to carefully cut or tear the four corners of the box so that the bottom of the box can be used as your work surface.
2. Remove all of the contents from box and verify that you have all of the parts shown on the Parts List before you begin assembly. **Note: Some parts may be pre-installed or pre-assembled.**
3. Some figures or drawings may not look exactly like product.
4. **When installing parts that have more than one screw or bolt, hand tighten all screws or bolts in place before final tightening with screwdriver or wrench.**
5. Electric screwdrivers may be helpful during assembly; however, please set a **low torque** and use extreme caution because screws may be stripped or overtightened, resulting in damaged parts, if the electric screwdriver's torque is set too high.



CARE AND USE





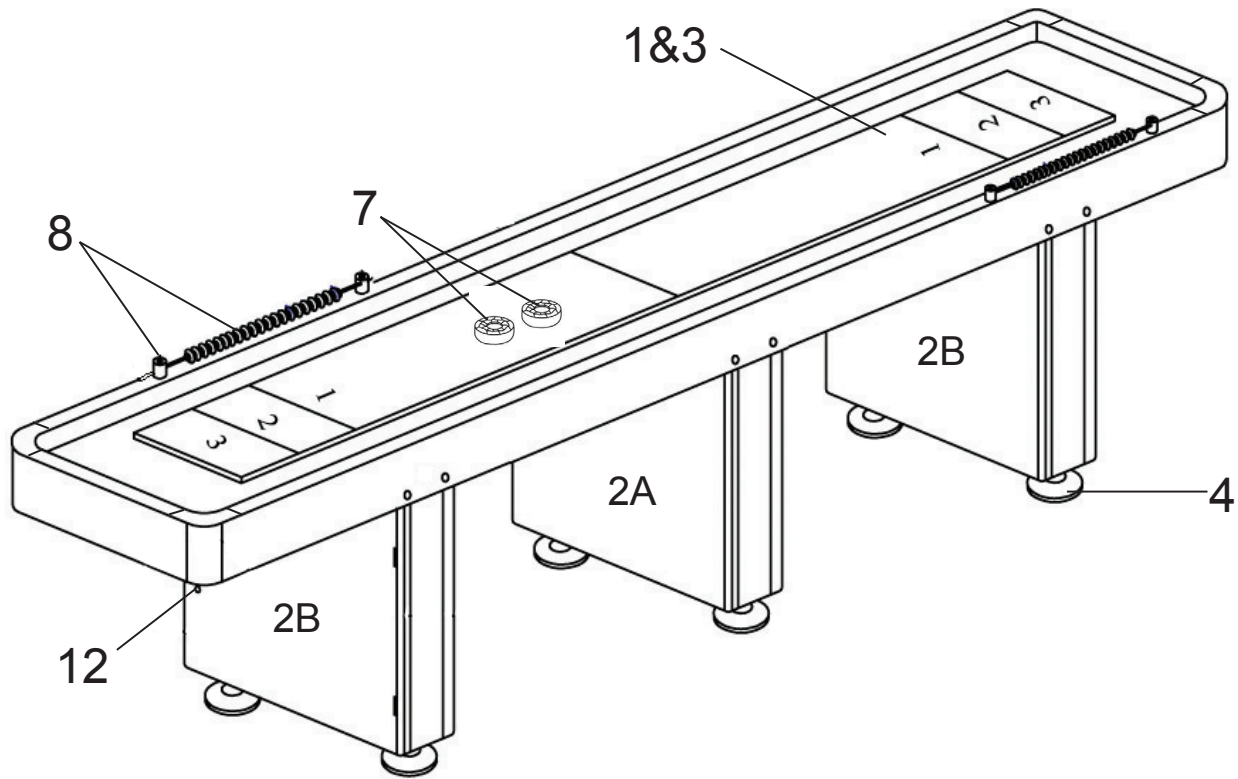

1. This product is intended for **INDOOR** use only.
2. Do **NOT** drag the table when moving it, as this will damage the legs.

14' CHALLENGER DK. CHERRY SHUFFLEBOARD TABLE - NG1216 Parts List

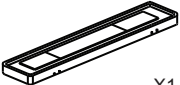
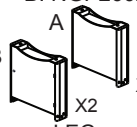

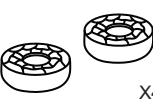
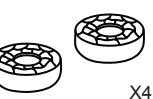

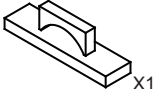

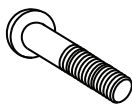

Illustrations Not to Scale

PARTS

#1&3 NGP5897  X1 TABLE BODY AND PLAYFIELD	#2 A: NGP26022 B: NGP26021  X2 X1 LEG	#4 NGP2603  X6 LEG LEVELER	#7 NGP2606  X4 RED PUCK	#7 NGP2607  X4 BLUE PUCK	#8 NGP2608  X2 MANUAL SCORER	#12 NGP2610  X2 DOOR HANDLE
#14 NG1222  X1 SHUFFLEBOARD BRUSH	#15 NG1220  X1 SHUFFLEBOARD WAX					

HARDWARE PACK - NGP58981





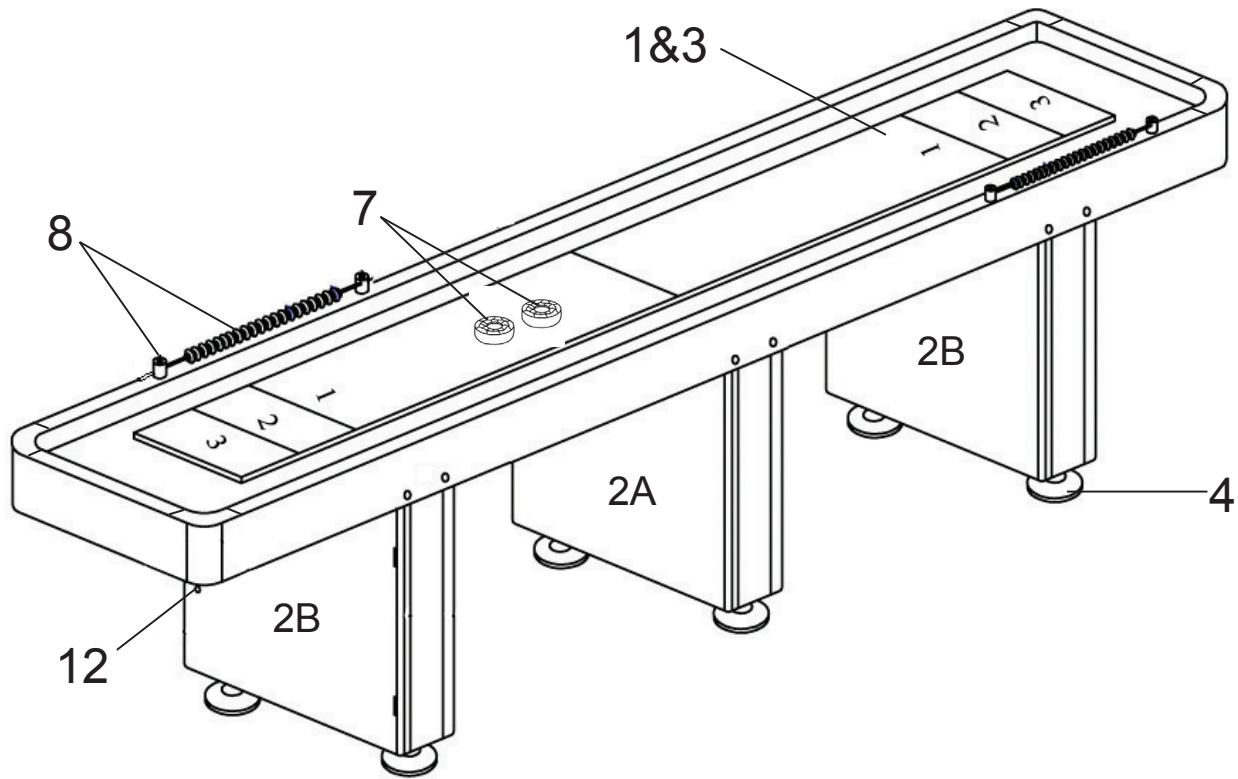

#5 X12  3/8" x 3" BOLT	#6 X12  3/8" x 1" WASHER	#9 X4  1-1/2" SCREW	#10 X12  NUT	#11 X1  WRENCHES	ADDITIONAL EQUIPMENT REQUIRED:  PHILLIPS HEAD SCREWDRIVER
--	--	---	--	---	--

14' CHALLENGER WALNUT SHUFFLEBOARD TABLE - NG1218 Parts List

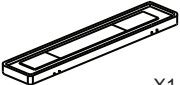
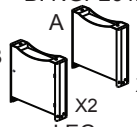

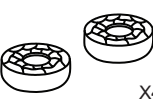
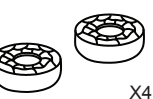

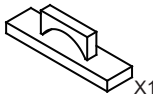

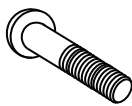

Illustrations Not to Scale

PARTS

<p>#1&3 NGP2670</p>  <p>X1 TABLE BODY AND PLAYFIELD</p>	<p>#2 A: NGP26122 B: NGP26121</p>  <p>X2 X1 LEG</p>	<p>#4 NGP2603</p>  <p>X6 LEG LEVELER</p>	<p>#7 NGP2606</p>  <p>X4 RED PUCK</p>	<p>#7 NGP2607</p>  <p>X4 BLUE PUCK</p>	<p>#8 NGP2615</p>  <p>X2 MANUAL SCORER</p>	<p>#12 NGP2616</p>  <p>X2 DOOR HANDLE</p>
<p>#14 NG1222</p>  <p>X1 SHUFFLEBOARD BRUSH</p>	<p>#15 NG1220</p>  <p>X1 SHUFFLEBOARD WAX</p>					

HARDWARE PACK - NGP58981

<p>#5 X12</p>  <p>3/8" x 3" BOLT</p>	<p>#6 X12</p>  <p>3/8" x 1" WASHER</p>	<p>#9 X4</p>  <p>1-1/2" SCREW</p>	<p>#10 X12</p>  <p>NUT</p>	<p>#11 X1</p>  <p>WRENCHES</p>	<p>ADDITIONAL EQUIPMENT REQUIRED:</p>  <p>PHILLIPS HEAD SCREWDRIVER</p>
--	--	---	--	---	--

ASSEMBLY INSTRUCTIONS

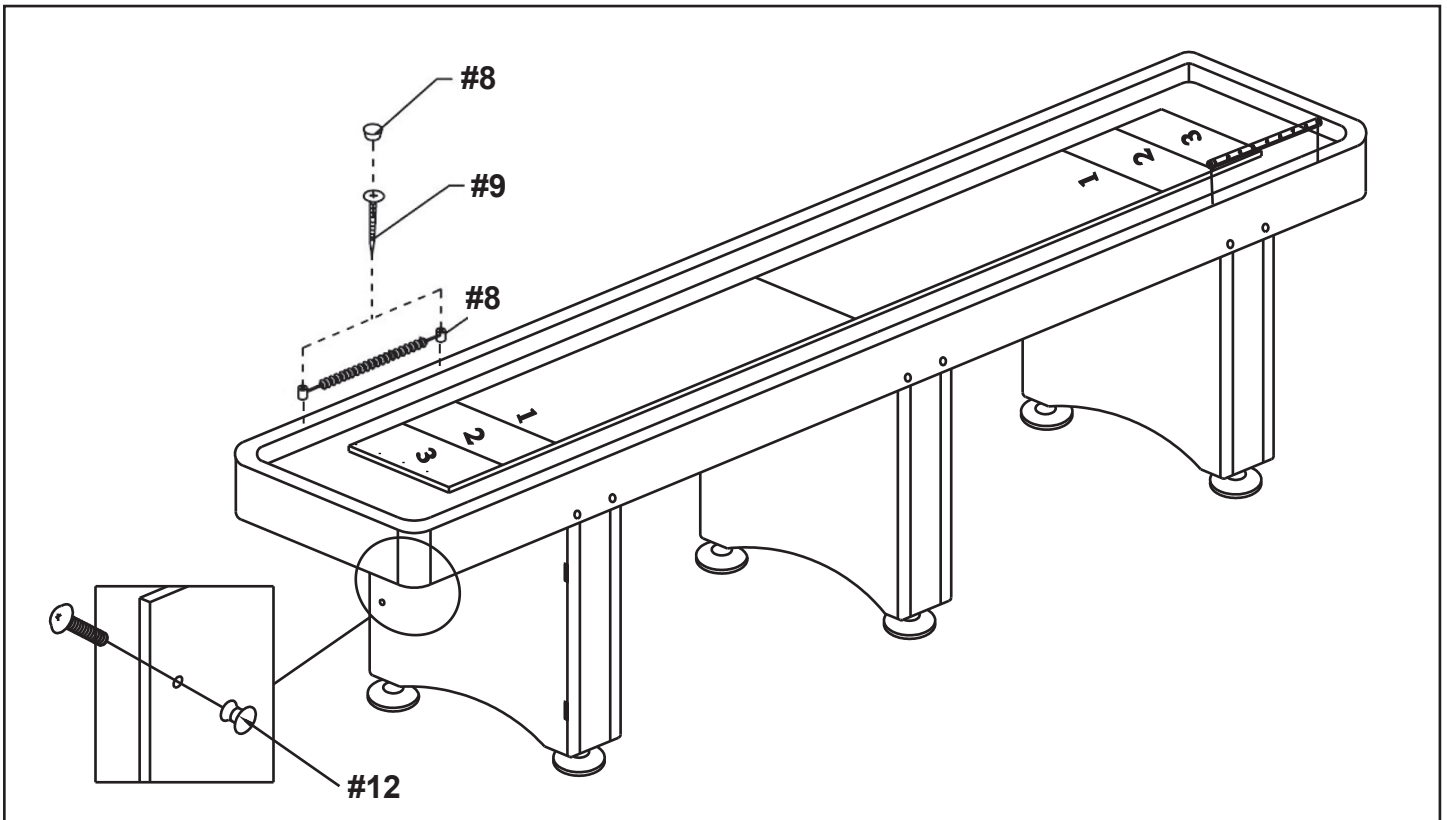
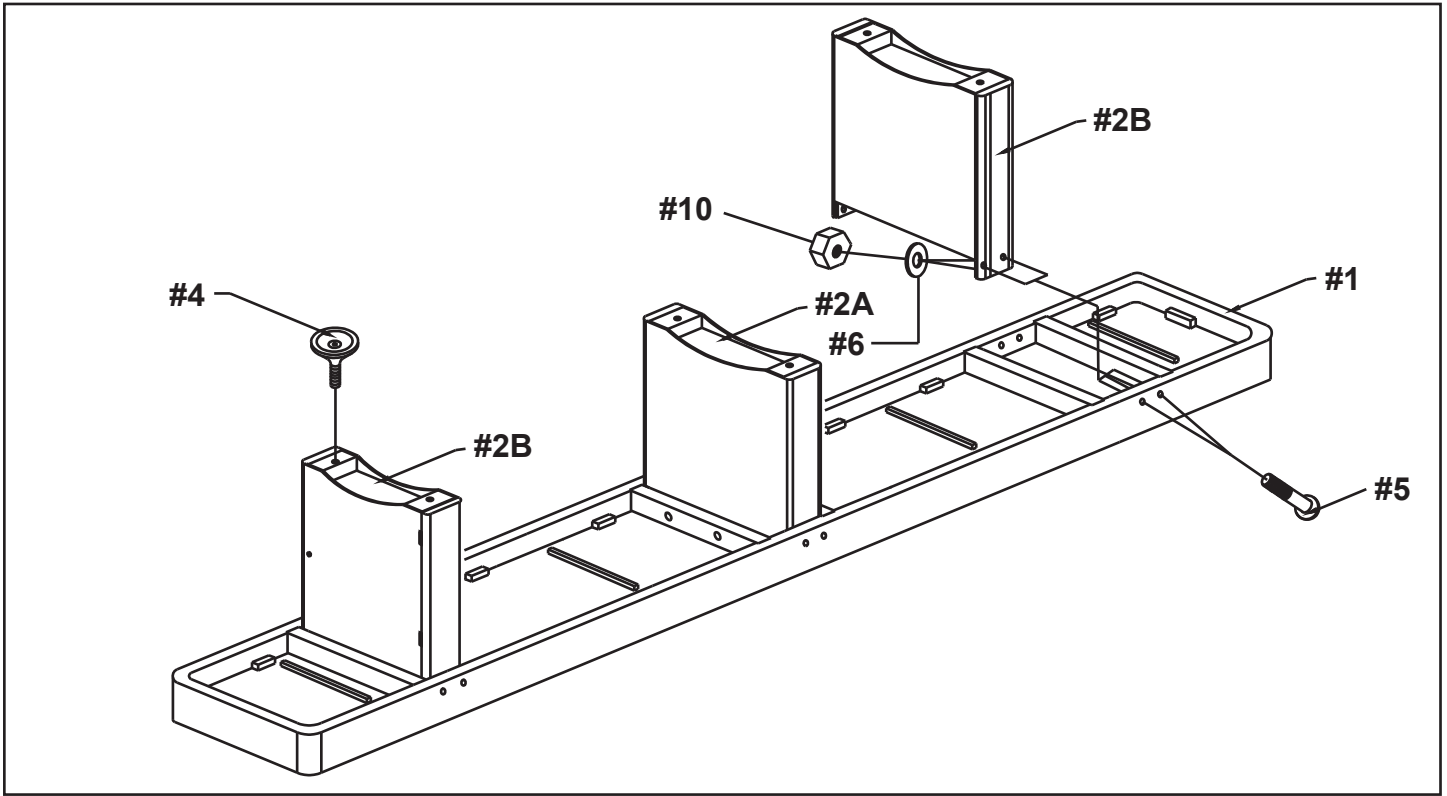

ASSEMBLY INSTRUCTIONS (CONT.)

You have now assembled your Game Table. Please note the Care and Use instructions below to ensure years of trouble free use of your game table.

CARE AND USE

1. This product is intended for INDOOR use only.
2. Do NOT sit, climb or lean on the table.
3. Do NOT drag the table when moving it as this will damage the legs.
4. This Shuffleboard is equipped with Climatic Adjusters underneath the table to level the playfield. Because of humid weather or dry conditions, it is occasionally necessary to make adjustments in order to keep the playfield true. **Make sure your table is level in both directions using Leg Levelers before making any adjustments using the Climatic Adjusters.**

If necessary, begin the adjustment process by placing a straight edge across the playfield directly above the first Climatic Adjuster at either end of the table. This will determine if the playfield is concave or convex. The shuffleboard surface should be slightly concave to prevent the pucks from falling off the sides of the board.

Each Climatic Adjuster consists of three anchor bolts attached to the underside of the playfield through a metal bar. Adjustments will be made to the center bolt only. The outer two bolts are used to hold the metal bar in place.

To correct a convex playfield, loosen the nut above the metal bar. Slowly tighten the nut below the metal bar up against the bar in order to pull the center of the playfield down.

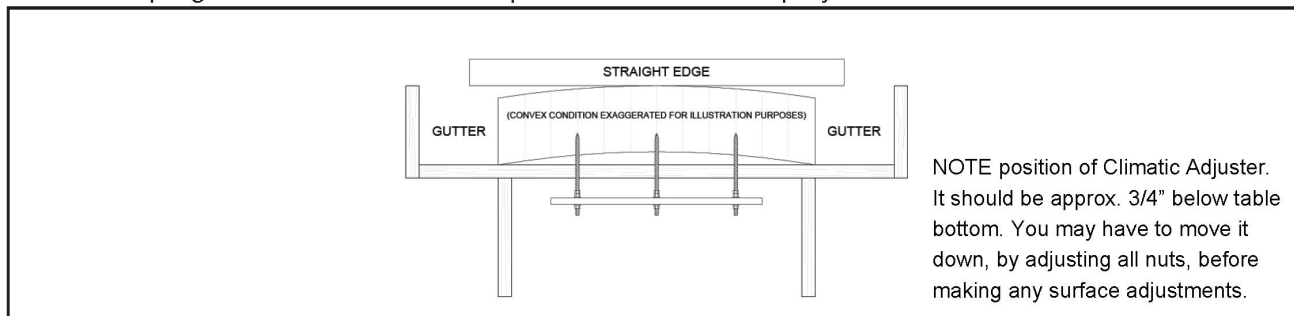

To correct a concave playfield, loosen the nut below the metal bar. Slowly tighten the nut above the metal bar down against the bar in order to push the center of the playfield up.

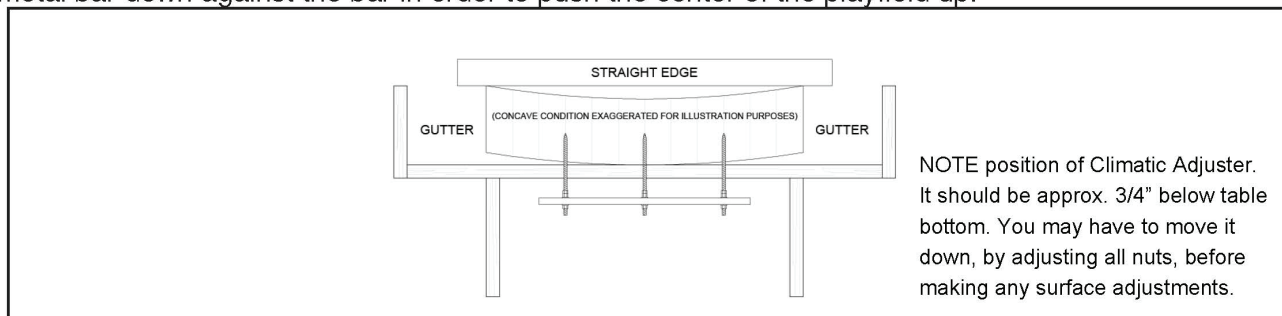

Important: nuts should be tightened slowly with 1/4 to 3/4 turns at a time. It may take a few days for the shuffleboard to completely react. DO NOT over tighten, as this can cause permanent damage to the Climatic Adjusters and your table.

Once the desired adjustment has been made, continue to the next Climatic Adjuster and repeat the process.

Please note that the shuffleboard will react to the adjustments for several days. Check the playfield again after a few days to determine if further adjustments are needed.

180-DAY LIMITED WARRANTY

This product is warranted to the original purchaser to be free from defects in material or workmanship for a period of 180 days from the date of the original retail purchase.

This warranty does not cover defects or damage due to improper installation, alteration, accident or any other event beyond the control of the manufacturer. Defects or damage resulting from misuse, abuse or negligence will void this warranty. This warranty does not cover scratching or damage that may result from normal usage.

This product is not intended for institutional or commercial use; the manufacturer does not assume any liability for such use. Institutional or commercial use will void this warranty.

This warranty is nontransferable and is expressly limited to the repair or replacement of the defective product. During the warranty period, the manufacturer shall repair or replace defective parts at no cost to the purchaser. Shipping charges and insurance are not covered and are the responsibility of the purchaser. Labor charges and related expenses for removal, installation or replacement of the product or components are not covered under this warranty.

The manufacturer reserves the right to make substitutions to warranty claims if parts are unavailable or obsolete.

The manufacturer shall not be liable for loss of use of the product or other consequential or incidental costs, expenses or damages incurred by the consumer of any other use. The user assumes all risk of injury resulting from the use of this product.

This warranty is expressly in lieu of all other warranties, expressed or implied, including warranties of merchantability or fitness for use to the extent permitted by Federal or state law. Neither the manufacturer nor any of its representatives assumes any other liability in connection with this product.

All warranty claims must be made through the retailer where the product was originally purchased. A purchase receipt or other proof of date of purchase will be required to process all warranty claims. The model number and part numbers found within the assembly instructions will be required when submitting any parts requests or warranty claims.

For further warranty information or inquiries, please call 800-759-0977

TABLE DE SHUFFLEBOARD CHALLENGER 4,2 m INSTRUCTION D'ASSEMBLAGE



Des questions, des problèmes, des pièces manquantes ?

Contactez le service à la clientèle de Blue Wave au 1-800-759-0977, du lundi au vendredi, 8am - 5pm (CST).

MERCI!

Merci d'avoir acheté notre produit. Nous travaillons 24 heures sur 24, partout dans le monde, à garantir que nos produits sont de la meilleure qualité possible. Toutefois, dans les rares cas de problèmes lors du montage ou de l'utilisation de ce produit, se il vous plaît communiquer avec notre service à la clientèle au **800-759-0977** pour une aide immédiate avant de contacter votre revendeur. Pour obtenir de plus amples renseignements, veuillez lire l'information relative à la garantie au verso de ce guide d'instructions.

INSTRUCTIONS D'ASSEMBLAGE

IMPORTANT! VEUILLEZ LIRE, EN ENTIER, TOUTES LES INSTRUCTIONS AVANT D'ASSEMBLER VOTRE PRODUIT.

1. Trouver une surface propre et plane, pour commencer le montage de votre table de jeu. La table s'assemble à l'envers pour être ensuite retournée sur ses pieds, une fois l'assemblage complété. Cette table est lourde et nécessite au moins deux adultes forts pour la soulever et la retourner.
2. Retirez le contenu de la boîte, avant de commencer l'assemblage, assurez-vous d'avoir toutes les pièces telles que listées et illustrées au tableau d'identification. **Avis : certaines pièces sont préassemblées ou préinstallées.**
3. Certaines illustrations ou dessins peuvent ne pas ressembler au produit que vous avez acheté.
4. **Quand vous fixez en place une pièce avec plus d'une vis ou écrou, veuillez, en premier, les visser à la main et terminer la fixation avec un tournevis ou une clé.**
5. Un tournevis électrique peut être utile lors de l'assemblage, mais veuillez le régler à **basse torque** et l'utiliser avec prudence; si la torque est trop élevée, la vis peut se défaire ou être trop serrée.



ENTRETIEN ET USAGE





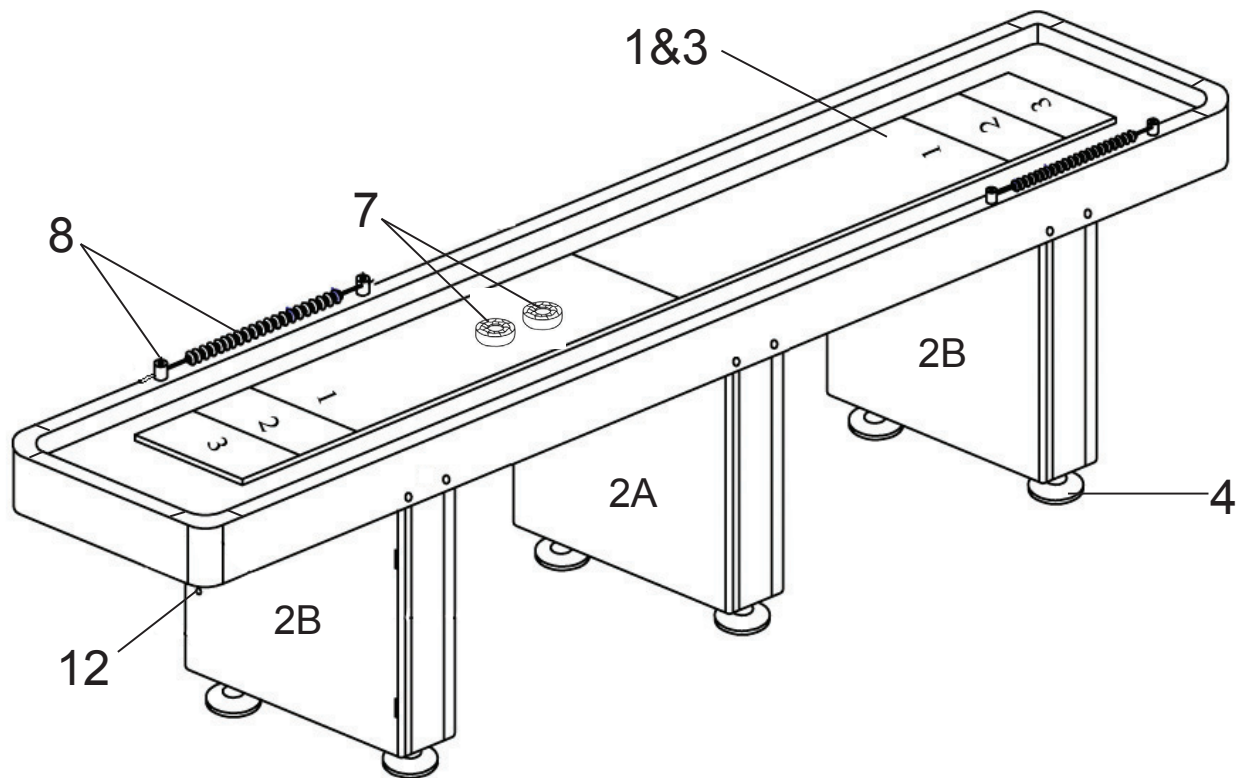

1. Ce produit doit être utilisé **À L'INTÉRIEUR** seulement.
2. **NE JAMAIS** déplacer la table en la traînant, cela pourrait endommager les pieds.

TABLE DE SHUFFLEBOARD CHALLENGER MERISIER (4,2 m) NG1216 Liste des pièces

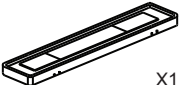
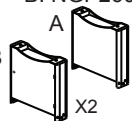

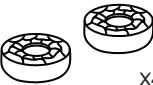
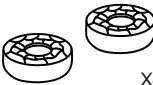
illustrations non à l'échelle

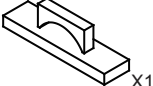
PIÈCES

#1&3 NGP5897  X1 STRUCTURE PRINCIPALE ET SURFACE DE JEU	#2 A: NGP26022 B: NGP26021  X2 X1 A B PIED	#4 NGP2603  X6 PATIN DE NIVELLEMENT	#7 NGP2606  X4 RONDELLES DE SHUFFLEBOARD ROUGES	#7 NGP2607  X4 RONDELLES DE SHUFFLEBOARD BLEUES	#8 NGP2608  X2 COMPTEUR MANUEL	#12 NGP2610  X2 POIGNÉE DE PORTE
#14 NG1222  X1 BROSSE DE PALETS	#15 NG1220  X1 CIRE DE SHUFFLEBOARD					

TROUSSE DE QUINCAILLERIE - NGP58981











#5 X12  BOULON (7,62 cm)	#6 X12  RONDELLE PLATE	#9 X4  VIS (3,81 cm)	#10 X12  ÉCROU	#11 X1  CLÉ	ÉQUIPEMENT ADDITIONNEL REQUIS  TOURNEVIS CRUCIFORME
--	--	--	--	--	--

TABLE DE SHUFFLEBOARD CHALLENGER NOYER (4,2 m) NG1218 Liste des pièces

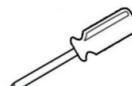
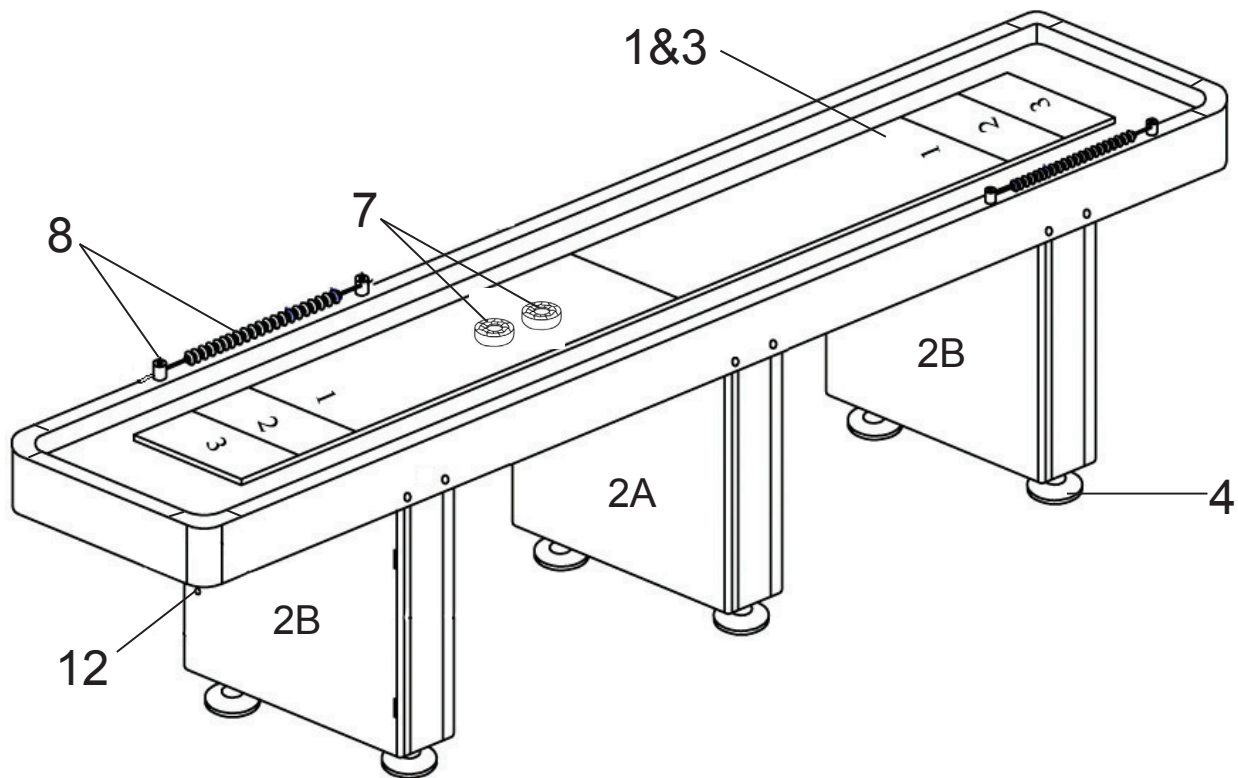
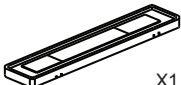
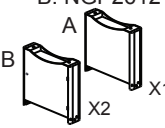

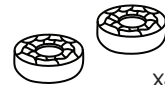
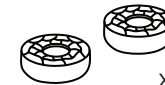

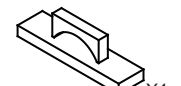

illustrations non à l'échelle

PIÈCES

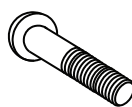
#1&3 NGP2670  X1 STRUCTURE PRINCIPALE ET SURFACE DE JEU	#2 A: NGP26122 B: NGP26121  X2 X1 A B PIED	#4 NGP2603  X6 PATIN DE NIVELLEMENT	#7 NGP2606  X4 RONDELLES DE SHUFFLEBOARD ROUGES	#7 NGP2607  X4 RONDELLES DE SHUFFLEBOARD BLEUES	#8 NGP2615  X2 COMPTEUR MANUEL	#12 NGP2616  X2 POIGNÉE DE PORTE
#14 NG1222  X1 BROSE DE PALETS	#15 NG1220  X1 CIRE DE SHUFFLEBOARD					

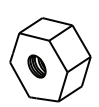
TROUSSE DE QUINCAILLERIE - NGP58981

#5 X12  BOULON (7,62 cm)	#6 X12  RONDELLE PLATE	#9 X4  VIS (3,81 cm)	#10 X12  ÉCROU	#11 X1  CLÉ	ÉQUIPEMENT ADDITIONNEL REQUIS  TOURNEVIS CRUCIFORME
--	--	--	--	--	--

INSTRUCTIONS D'ASSEMBLAGE

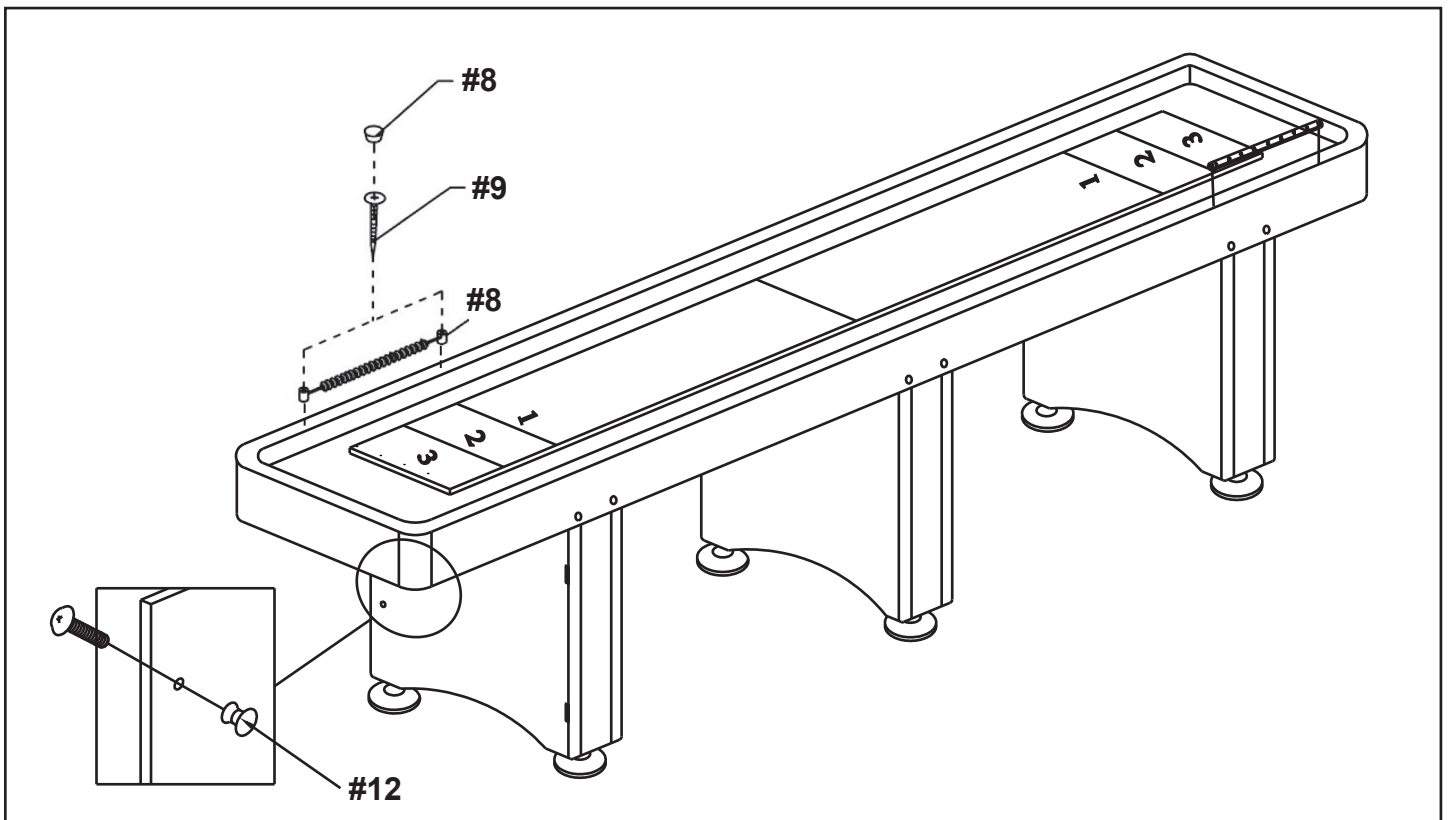
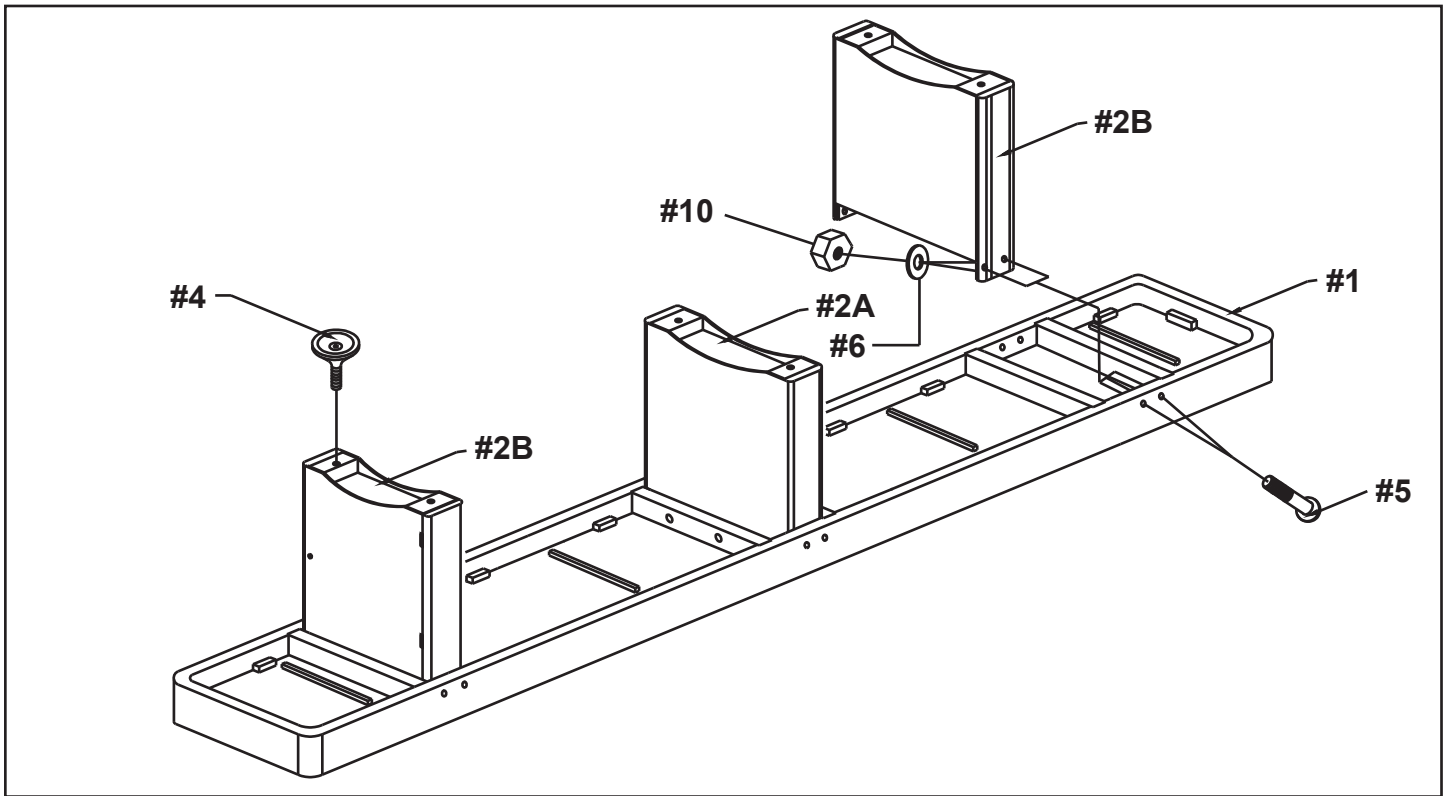

INSTRUCTIONS D'ASSEMBLAGE (suite)

Vous avez assemblé votre Table de Jeu. Afin de conserver votre table de shuffleboard longtemps, veuillez consulter les instructions en matière d'entretien et d'utilisation ci-dessous.

ENTRETIEN ET UTILISATION

1. Ce produit doit être utilisé à l'INTÉRIEUR seulement.
2. NE PAS s'asseoir, grimper ou s'appuyer sur la table de jeu.
3. NE PAS tirer sur la table pour la déplacer, cela risque d'endommager les pieds de la table.
4. Cette table de shuffleboard est équipée avec régulateurs climatiques sous la table pour niveler le terrain de jeu. En raison de temps sec ou humide, il est parfois nécessaire de faire des ajustements afin de garder l'aspect d'un terrain de jeu. Assurez-vous que votre table est de niveau dans les deux directions à l'aide de patins de nivellement avant de procéder aux réglages en utilisant les régulateurs climatiques. Si nécessaire, commencez le processus d'ajustement en plaçant une règle droite sur l'aire de jeu directement au-dessus des régulateurs climatiques situés aux deux extrémités de la table. Ceci déterminera si l'aire de jeu est concave ou convexe. La surface de jeu doit être légèrement concave pour empêcher les rondelles de tomber dans le dalot. Chaque régulateur climatique se compose de trois tiges de scellement fixées au-dessous de l'aire de jeu à travers une barre de fer. Effectuez des ajustements en utilisant le boulon central seulement. Les deux autres boulons servent à maintenir la barre métallique en place. Pour corriger une surface convexe, desserrez l'écrou au-dessus de la barre métallique. Serrez doucement l'écrou sous la barre de métal contre la barre afin d'abaisser le centre de la surface de jeu.

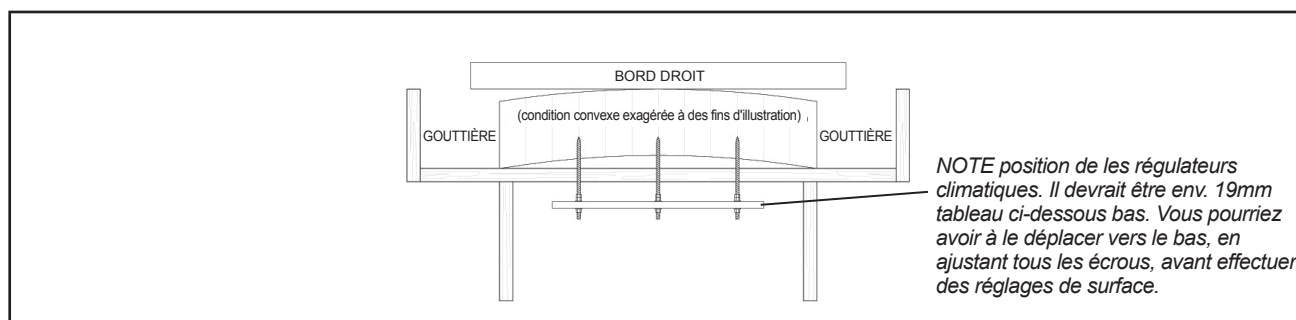

Pour corriger un terrain concave, desserrez l'écrou sous la barre de métal et serrez lentement l'écrou au-dessus de la barre métallique vers le bas contre la barre afin de pousser le centre de la surface de jeu vers le haut.

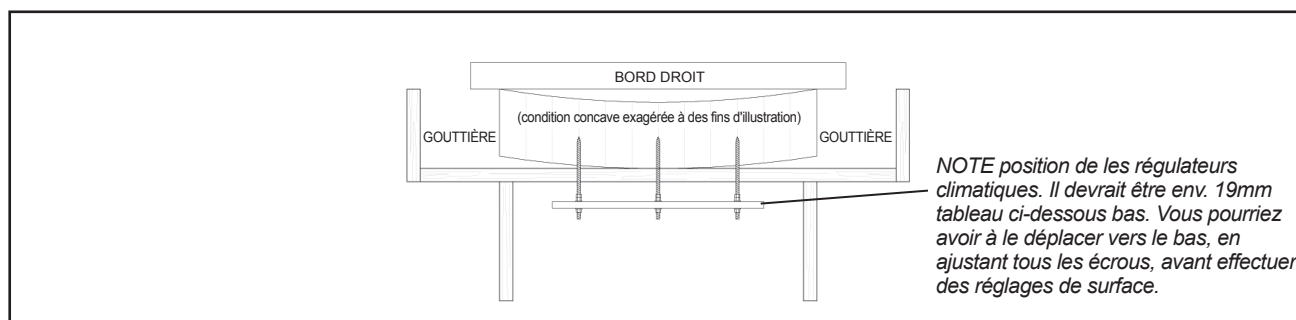

Important : les écrous doivent être serrés lentement d'un $\frac{1}{4}$ de tour et de $\frac{3}{4}$ de tour à la fois. Il peut prendre quelques jours pour le surface de jeu ne réagisse complètement. NE pas trop serrer, car ceci peut causer des dommages permanents aux régulateurs climatiques et à votre table.

Une fois le réglage désiré est effectué, déplacez-vous vers l'autre régulateur climatique et répétez le processus.

Veuillez noter que la table de shuffleboard réagira aux ajustements pendant plusieurs jours. Vérifiez de nouveau la surface de jeu après quelques jours pour déterminer si d'autres ajustements sont nécessaires.

GARANTIE LIMITÉE DE 180 JOURS

La garantie du produit est valide pour l'acheteur original en ce qui a trait aux pièces défectueuses ou à la main-d'œuvre pour une période de 180 jours de la date d'achat.

Cette garantie n'est couverte pas les dommages causés par accident, par modification, par une installation défectueuse ou tout autre événement hors du contrôle du fabricant. Tout défaut ou dommage résultant de la négligence ou d'une mauvaise utilisation annule cette garantie. La présente garantie ne couvre pas les égratignures ou les dommages attribuables à un usage normal.

Ce produit n'est pas destiné à un usage institutionnel ou commercial; le fabricant décline toute responsabilité pour une telle utilisation. Un usage institutionnel ou commercial annule cette garantie.

Cette garantie est non transférable et est expressément limitée à la réparation ou au remplacement du produit défectueux. Au cours de la période de garantie, le fabricant s'engage à remplacer et à réparer les pièces défectueuses sans frais pour l'acheteur. Les frais d'assurance et d'expédition ne sont pas couverts et sont à la charge de l'acheteur. Les frais de main-d'œuvre et les dépenses liées au déplacement, à l'installation ou au remplacement du produit ou de ses composantes ne sont pas couverts par cette garantie.

Le fabricant se réserve le droit de faire des substitutions de recours en garantie si la pièce n'est pas disponible ou obsolète.

Le fabricant décline toute responsabilité liée à la perte d'utilisation ainsi que tous les autres coûts directs ou indirects, frais ou dommages encourus par le consommateur qui aurait été causés par une autre utilisation. L'utilisateur assume tous les risques de dommage résultant de l'utilisation de ce produit.

Cette garantie tient lieu expressément de toute autre garantie, exprimée ou implicite, y compris les garanties de qualité marchande ou d'adaptation à un emploi particulier dans la mesure permise par les lois fédérales ou provinciales. Ni le fabricant, ni aucun de ses représentants n'assument aucune autre responsabilité en rapport avec ce produit.

Toute réclamation doit être faite par le détaillant où le produit a été acheté. Une facture ou autre preuve d'achat est nécessaire pour traiter toutes les réclamations de garantie. Le numéro de modèle et les numéros de référence figurant dans les instructions d'assemblage seront exigés lors de la soumission de demande de pièces ou de recours en garantie.

Pour plus d'information ou pour toute question, veuillez téléphoner au 1 800 759-0977.