

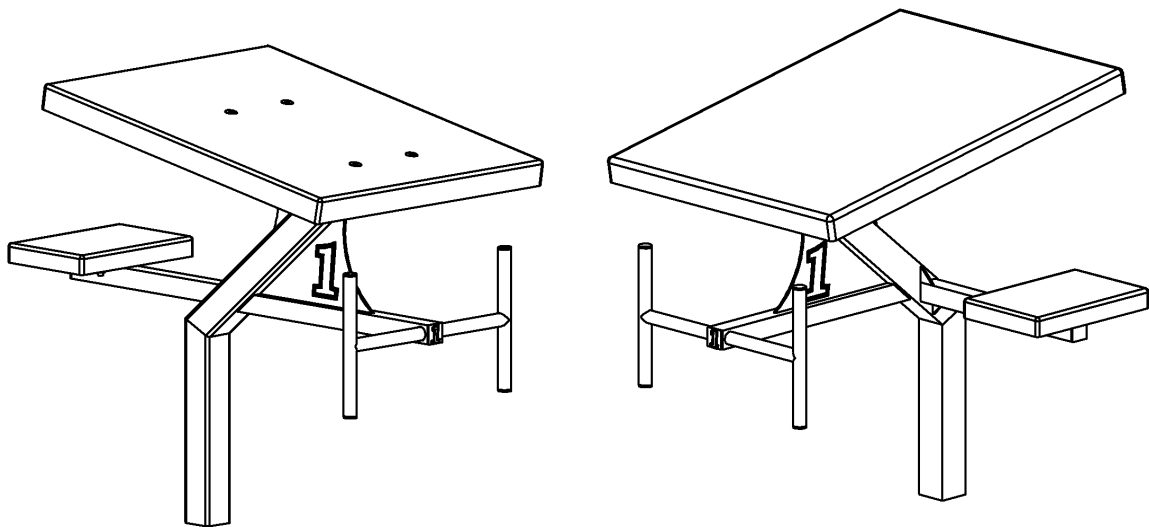

LEGACY AND VELOCITY STARTING PLATFORM

INSTALLATION INSTRUCTIONS



CORPORATE HEADQUARTERS
WESTERN SALES AND MANUFACTURING PLANT
P.O. Box 400 • 1017 SW Berg Parkway
Canby, Oregon 97013
(503) 266-2231 • Fax (503) 266-4334
www.srsmith.com

INTRODUCTION

The Legacy Starting Platforms are designed for use on competitive or municipal pools. Proper installation, use, and maintenance are essential for proper operation and to reduce the risk of accident or injury.

****IMPORTANT****

Check entire box and inside all packing materials for parts. Before beginning assembly, read the instructions and identify parts using the figures and parts listed in this document. It is critical that all parts be carefully inspected by the installer prior to installation to ensure that no damage occurred in transit and that a damaged part is not used. Proper installation cannot be overstressed, as an improper installation voids S.R. Smith's warranty and may affect the safety of the user.

LEGACY STARTING PLATFORM PARTS LIST

ITEM NO.	QTY.	PART NO.	DESCRIPTION
1	1	27-107	WEDGE ANCHOR ASSY-SINGLE POST PLAT.
2	1	STARTING BLOCK	LEGACY STARTING PLATFORM
3	1	EP-300	ESCUTCHEON, SQUARE 2.5" X 2.5"

AVAILABLE MODELS			
ITEM NO.	DESCRIPTION	FOOTBOARD	STEP
LEGACY-SP-9999	LEGACY WITH ANCHOR	8-623B	74-228-2283A
LGCYL1-SP-9999	LEGACY LONG REACH WITH ANCHOR	8-623B	74-228-2283A
LSM-9999	LEGACY SIDE MOUNT WITH ANCHOR	8-623B	74-228-2283A

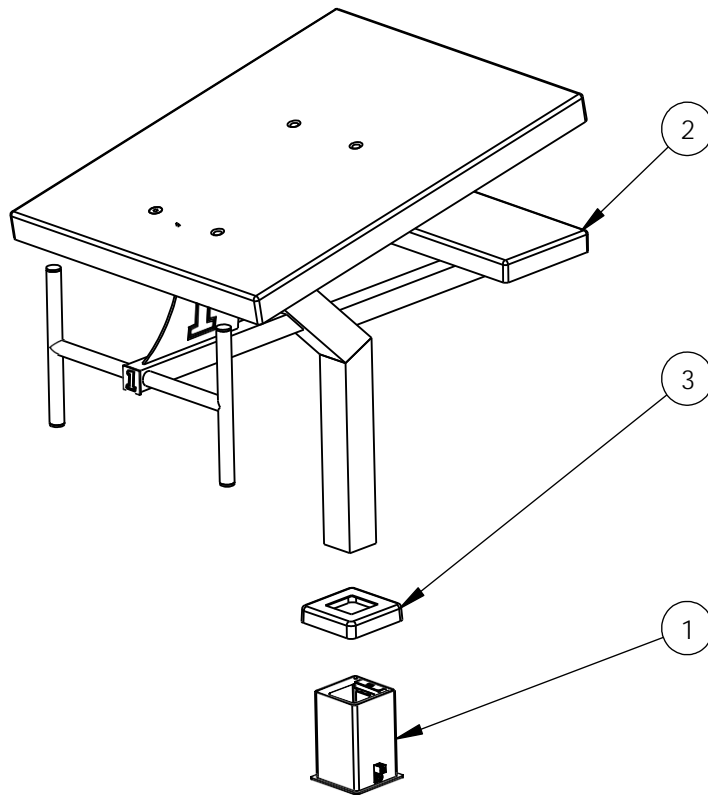

FIGURE 1

LEGACY DUAL POST STARTING PLATFORM PARTS LIST

ITEM NO.	QTY.	PART NO.	DESCRIPTION
1	1	27-108	WEDGE ANCHOR ASSY-DUAL POST PLAT.
2	1	STARTING BLOCK	LEGACY DUAL POST STARTING PLATFORM
3	2	EP-306R-PC	ESCUTCHEON, 6" ROUND POWDERCOATED

AVAILABLE MODELS			
ITEM NO.	DESCRIPTION	FOOTBOARD	STEP
LEGACY-DP-SP-9999A	LEGACY DUAL POST	8-623B	74-228-2283A
LGCYL2-DP-SP-9999A	LEGACY DUAL POST LONG REACH	8-623B	74-228-2283A

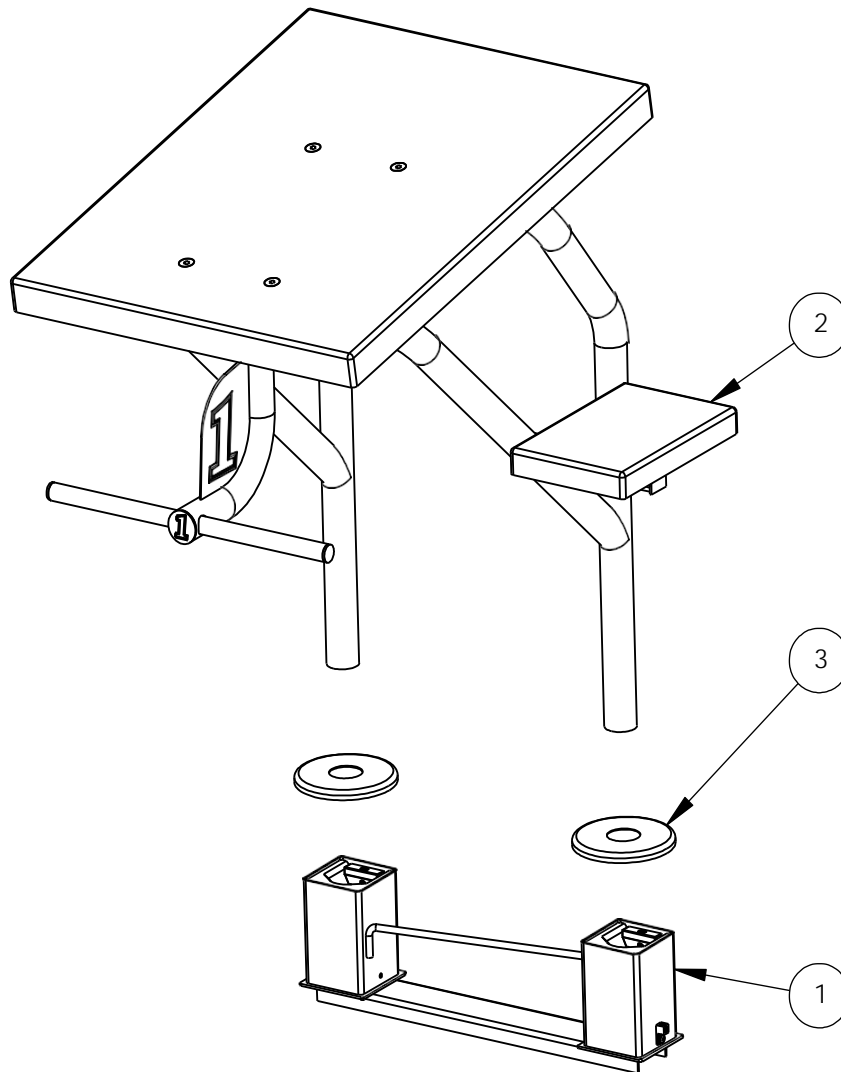

FIGURE 2

VELOCITY STARTING PLATFORM PARTS LIST

ITEM NO.	QTY.	PART NO.	DESCRIPTION
1	1	STARTING BLOCK	VELOCITY STARTING PLATFORM
2	1	27-107	WEDGE ANCHOR ASSY-SINGLE POST PLAT.
3	1	EP-300	ESCUTCHEON, SQUARE 2.5" X 2.5"

AVAILABLE MODELS				
TRUETREAD™				
ITEM NO.	DESCRIPTION	FOOTBOARDS	STEP	TRACK START
VELO-TS-TA	Standard /Track Start	8-620TS-T-1	8-760-T	4-62TS-T
VELOSM-TS-TA	SIDE MOUNT / Track Start	8-620TS-T-1	8-760-T	4-62TS-T
VELOMR-TS-TA	Mid-Range / Track Start	8-620TS-T-1	8-760-T	4-62TS-T
VELOLR-TS-TA	Long Reach / Track Start	8-620TS-T-1	8-760-T	4-62TS-T
VELO-TA	Standard	8-620-T-1	8-760-T	N/A
VELOSM-TA	Side Mount	8-620-T-1	8-760-T	N/A
VELOMR-TA	Mid-Range	8-620-T-1	8-760-T	N/A
VELOLR-TA	Long Reach	8-620-T-1	8-760-T	N/A
SAND TREAD				
VELO-TS-SA	Standard /Track Start	8-620TS-S-1	8-760-S	4-620TS-S
VELOSM-TS-SA	SIDE MOUNT / Track Start	8-620TS-S-1	8-760-S	4-620TS-S
VELOMR-TS-SA	Mid-Range / Track Start	8-620TS-S-1	8-760-S	4-620TS-S
VELOLR-TS-SA	Long Reach / Track Start	8-620TS-S-1	8-760-S	4-620TS-S
VELO-SA	Standard	8-620-S-1	8-760-S	N/A
VELOSM-SA	Side Mount	8-620-S-1	8-760-S	N/A
VELOMR-SA	Mid-Range	8-620-S-1	8-760-S	N/A
VELOLR-SA	Long Reach	8-620-S-1	8-760-S	N/A

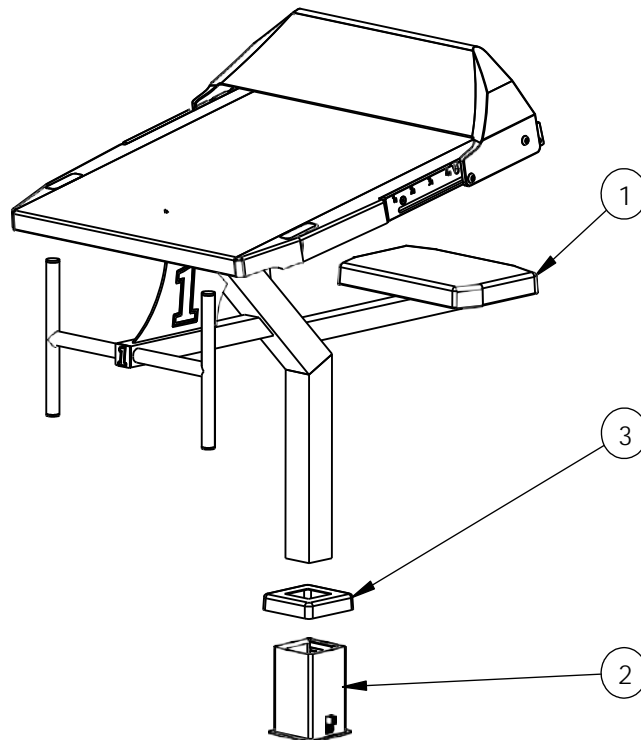

FIGURE 3

VELOCITY DUAL POST STARTING PLATFORM PARTS LIST

ITEM NO.	QTY.	PART NO.	DESCRIPTION
1	1	STARTING BLOCK	VELOCITY DUAL POST STARTING PLATFORM
2 Not Shown	1	27-108 27-105	WEDGE ANCHOR ASSY-DUAL POST PLAT. ANCHOR ASSY-DUAL POST PLATFORM
3	2	EP-306R-PC	ESCUTCHEON, 6" ROUND POWDERCOATED

NOTE: 27-108 RECOMMENDED

AVAILABLE MODELS				
TRUETREAD™				
ITEM NO.	DESCRIPTION	FOOTBOARD	STEP	TRACK START
VELO-DP-TS-TA	Standard /Track Start	8-620TS-T-1	8-760-T	4-620TS-S
VELOLR-DP-TS-TA	Long Reach / Track Start	8-620TS-T-1	8-760-T	4-620TS-S
VELO-DP-TA	Standard	8-620-T-1	8-760-T	N/A
VELOLR-DP-TA	Long Reach	8-620-T-1	8-760-T	N/A
SAND TREAD				
VELO-DP-TS-SA	Standard /Track Start	8-620TS-S-1	8-760-S	4-620TS-S
VELOLR-DP-TS-SA	Long Reach / Track Start	8-620TS-S-1	8-760-S	4-620TS-S
VELO-DP-SA	Standard	8-620-S-1	8-760-S	N/A
VELOLR-DP-SA	Long Reach	8-620-S-1	8-760-S	N/A

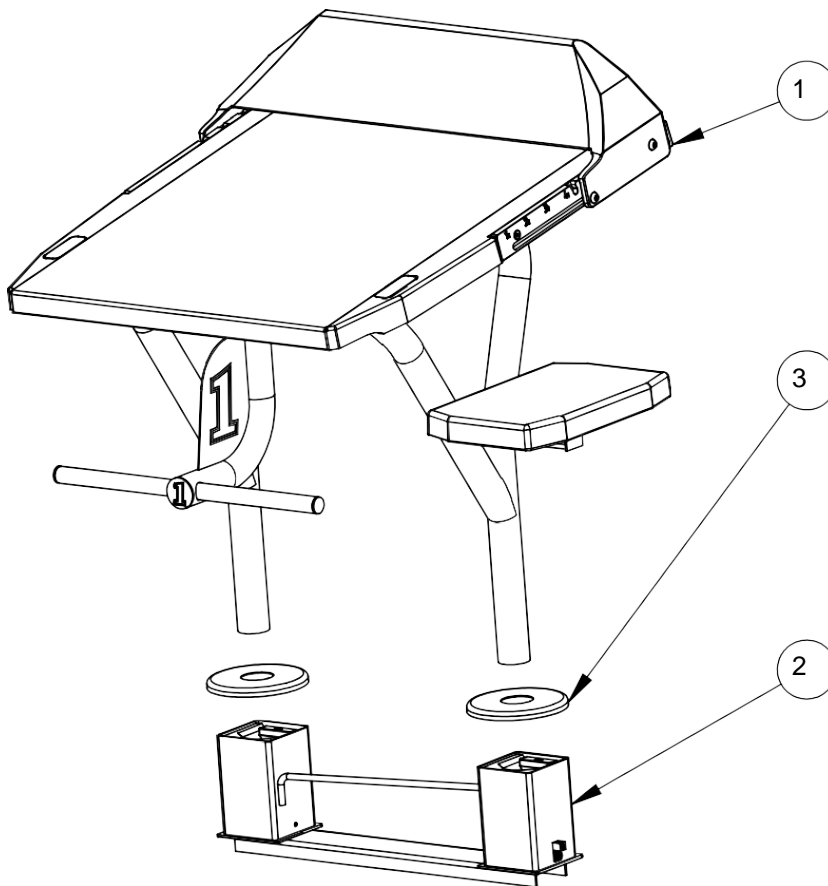

FIGURE 4

STARTING BLOCK INSTALLATION

The RockSolid™ anchor can be installed in an existing pool deck or set when pouring a new concrete deck.

1. The RockSolid™ wedge anchor part numbers, 27-107 shown in **FIGURE 5** and 27-108 shown in **FIGURE 6**, should be installed in the orientation shown. As shown in **FIGURE 5 and 6**, the side of the anchor that contains the wedge should be oriented such that it is parallel to, and farthest away from, the pool wall.

2. The setback for the anchor must be set using the correct distance "F" from the pool wall and with at least 6" from any control joint or edge of concrete slab. See **Figure 7**. The correct setback distance depends on the model ordered.

3. For the 27-107 anchor, SR Smith strongly advises the use of the Anchor Set Tool. With the S.R. Smith Anchor Set Tool (Part Number 27-109) it is important to subtract 1 ¼" from the correct setback distance because the tool measures from the front of the post and the setback is taken from the center of the post. See RockSolid™ instructions 6-674, for more details.

4. When the starting block is installed, the backstroke handles, and leading edge of the footboard shall be flush with the pool wall. Refer to **FIGURES 7**.

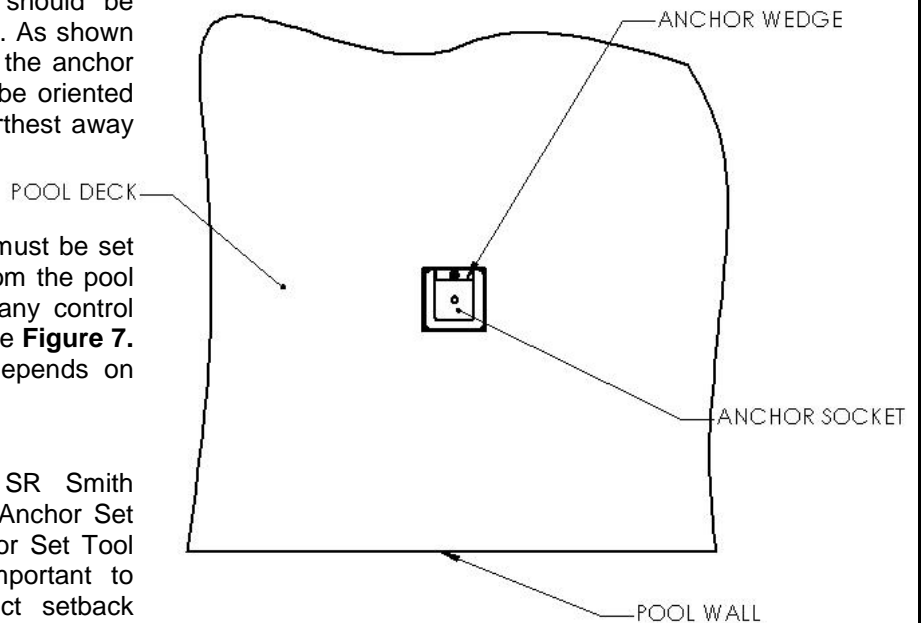

FIGURE 5

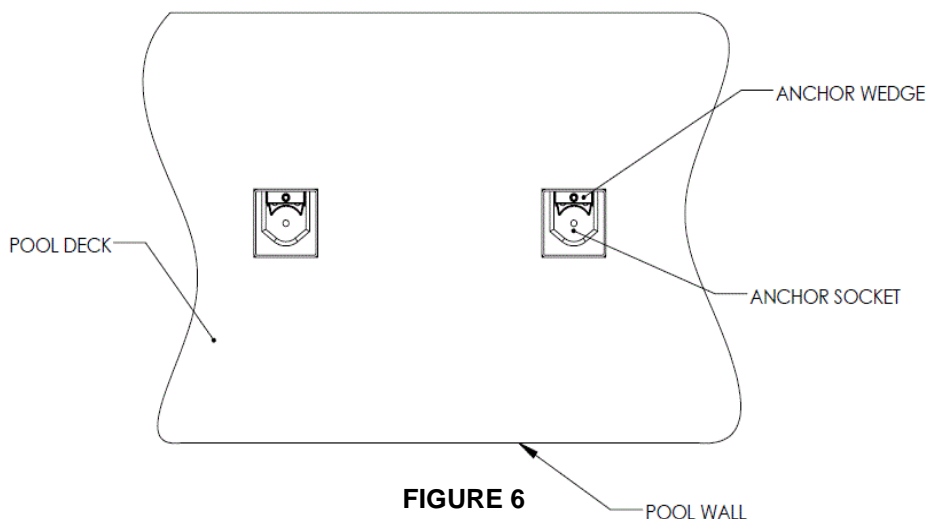

FIGURE 6

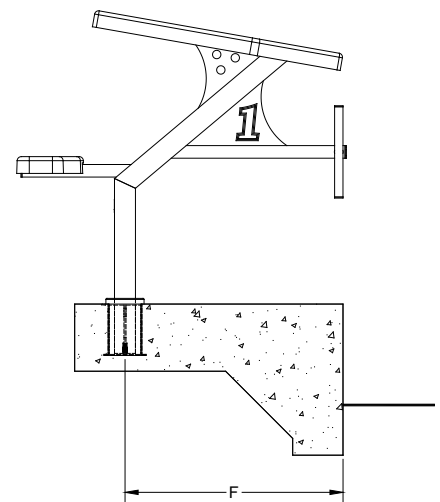

FIGURE 7

5. For anchor 27-107, Core drill at least a 6 ½-inch diameter hole at the chosen location for the anchor if installing the mounting anchor into an existing deck. See **FIGURE 8**. For anchor 27-108, core drill two holes at least a 6 ½"-inch in diameter and cut or chip out the concrete from in between the two holes. The anchor needs to be braced so it is not moved from its proper position during pouring of the deck.

6. Properly bond the anchor socket using the attached grounding lug and the appropriate grounding wire per local codes. The electrical bonding shall be done in accordance with Article No. 680 of the current National Electrical Code or the local code whichever is greater.

7. If installing in an existing deck, With the anchor completely checked for level and plumb in the selected position, pour hydraulic cement or high strength epoxy into the hole making sure there are no void spaces. If installation is new construction, ensure anchor is in its proper location and square to the pool wall before pouring concrete.

8. Let cement/grout cure for 24 hours (or minimum manufacture recommendation) before using starting platform.

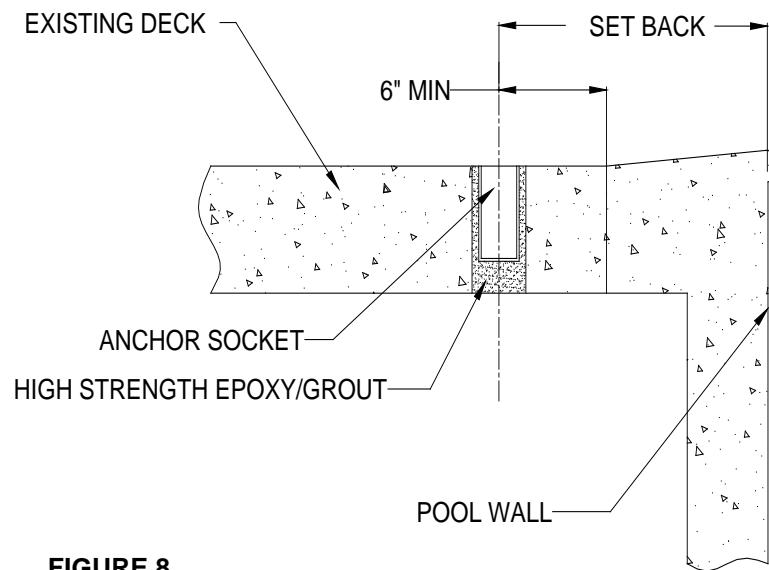

FIGURE 8

STARTING PLATFORM INSTALLATION AND REMOVAL:

When placing a starting platform into an anchor it's important to follow these simple instructions.

1. Loosen bolt using a ¼" ALLEN wrench, turning wrench in a counter-clockwise direction as seen from looking down. See **FIGURE 9**.
2. Make sure that the opening size directly adjacent to anchor bolt is between 2-9/16" (65mm) and 2-5/8" (66.7mm) wide. The opening in this direction should never exceed 2-5/8" (66.7mm) or the anchor will disassemble!
3. Place escutcheon over starting platform frame tube orienting as shown. For the long reach model make sure the escutcheon is orientated with the notch directly over the anchor bolt.
4. Place starting platform into anchor making sure that the platform frame rests completely on the bottom of the anchor and the forward edge of the starting platform faces the pool edge.
5. Tighten ALLEN wrench in the clockwise direction until anchor wedge contacts the starting platform frame and no forward or backward motion can be felt. When tightening anchor wedge, never exceed 8 Ft-Lbs. of torque. Anchor bolt should be snug but never over tightened.
6. After fully tightening the anchor bolt, apply a load to the starting block and then retighten the anchor bolt.

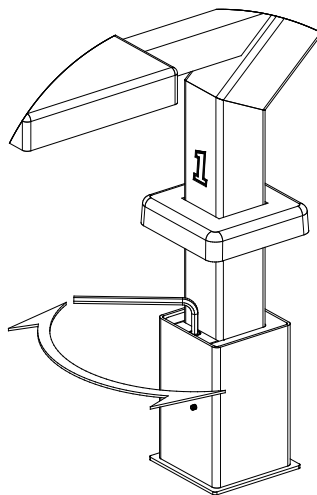

FIGURE 9

7. To remove starting platform, lift escutcheon, insert ALLEN wrench into anchor bolt and turn counter-clockwise two (2) full turns. For long reach models the anchor bolt is accessed through the notch in the escutcheon. Lift and remove starting platform. DO NOT continue to loosen anchor bolt or remove anchor bolt for any reason.

SAFETY & MAINTENANCE INSTRUCTIONS

- **Execute shallow racing dives only.**
- For use by trained competitive swimmers only.
- Periodically inspect the Legacy Starting Platform to assure there are no worn parts and that all hardware is properly tightened.
- All stainless-steel parts require periodic maintenance. Polishing with a cotton cloth and a Windex-type product maintains the finish and restores luster.
- Use non-abrasive soap and water. Avoid harsh chemicals and disinfectants. Always read the label instructions on any cleaner carefully before applying it to a surface.